



Service Manual

GREE ELECTRIC APPLIANCES, INC. OF ZHUHAI



Table of Contents

Part I : Technical Information	1
1. Summary	1
2. Specifications	6
2.1 Specification Sheet.....	6
2.2 Operation Characteristic Curve	34
2.3 Capacity Variation Ratio According to Temperature	34
2.4 Cooling and Heating Data Sheet in Rated Frequency.....	35
2.5 Noise Curve.....	36
3. Outline Dimension Diagram	37
3.1 Indoor Unit.....	37
3.2 Outdoor Unit.....	38
4. Refrigerant System Diagram	41
5. Electrical Part	43
5.1 Wiring Diagram	43
5.2 PCB Printed Diagram.....	53
6. Function and Control	60
6.1 Remote Controller Introduction	60
6.2 GREE+ App Operation Manual	80
6.3 Ewpe Smart App Operation Manual.....	81
6.4 Brief Description of Modes and Functions	82
Part II : Installation and Maintenance	93
7. Notes for Installation and Maintenance	93
8. Installation	97
8.1 Installation Dimension Diagram.....	97
8.2 Installation Parts-checking	99
8.3 Selection of Installation Location.....	99
8.4 Requirements for electric connection	99

8.5 Installation of Indoor Unit.....	100
8.6 Installation of Outdoor Unit.....	102
8.7 Vacuum Pumping and Leak	103
8.8 Check after Installation and Test Operation	103
9. Maintenance.....	104
9.1 Error Code List.....	104
9.2 Procedure of Troubleshooting	111
9.3 Troubleshooting for Normal Malfunction	124
10. Exploded View and Parts List	126
10.1 Indoor Unit.....	126
10.2 Outdoor Unit	172
11. Removal Procedure	184
11.1 Removal Procedure of Indoor Unit	184
11.2 Removal Procedure of Outdoor Unit.....	194
Appendix:	212
Appendix 1: Reference Sheet of Celsius and Fahrenheit.....	212
Appendix 2: Configuration of Connection Pipe	212
Appendix 3: Pipe Expanding Method.....	213
Appendix 4: List of Resistance for Temperature Sensor.....	214

Part I : Technical Information

1. Summary

Indoor Unit

A1 Panel

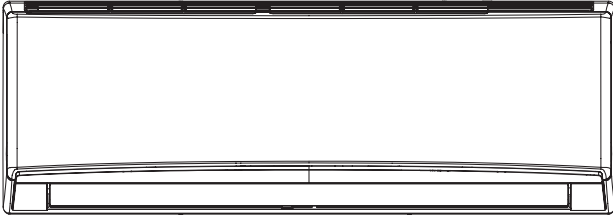

A5 Panel

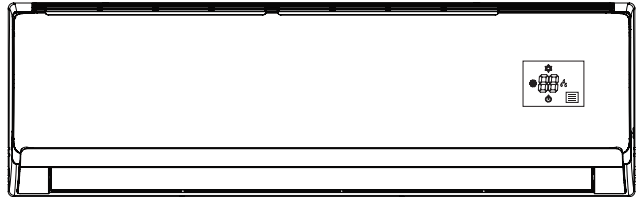

C2 Panel

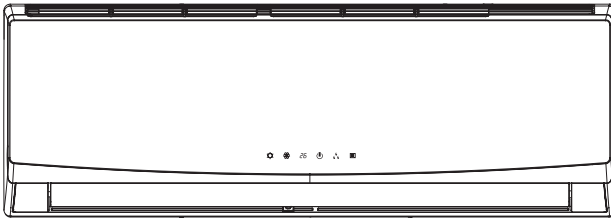

B6 Panel

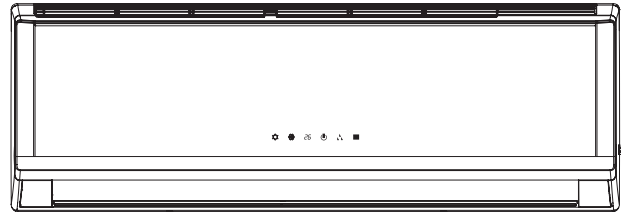

C4 Panel

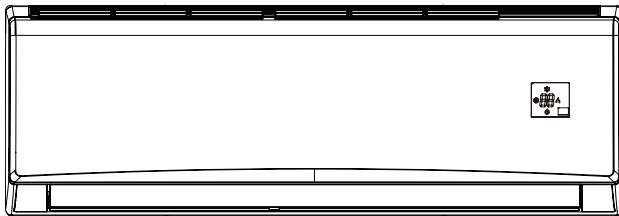

B4 Panel

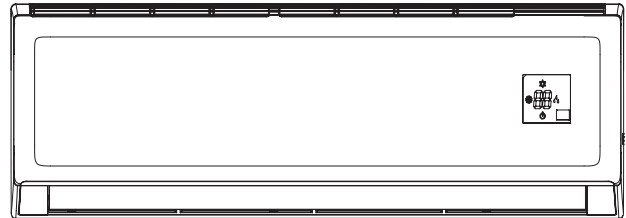

E4 Panel

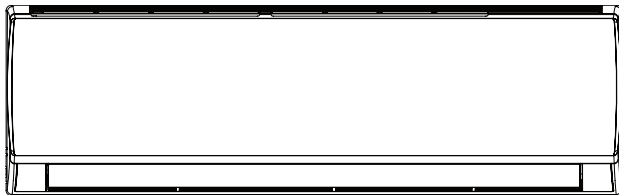

B2 Panel



B8 Panel

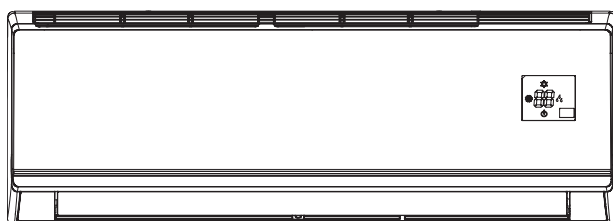

C6 Panel



A3 panel

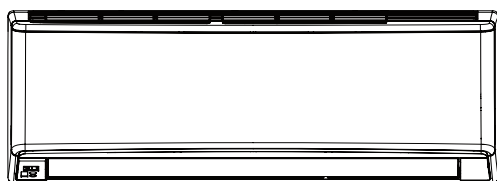

GWH18QD-K6DND2D/I(CB461N05700)
GWH24QE-K6DND2E/I(CB461N05600)

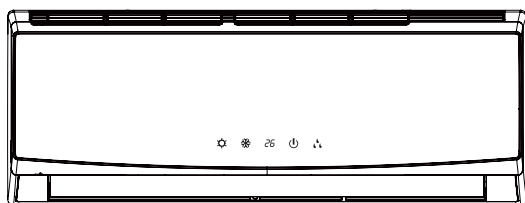

GWH18QD-K6DND2D/I(CB461N05702)
GWH24QE-K6DND2E/I(CB461N05602)

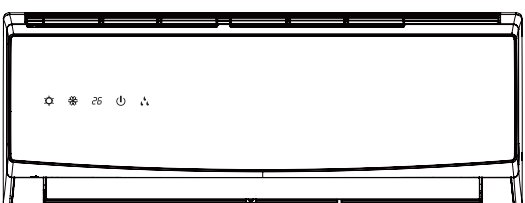

A2 panel

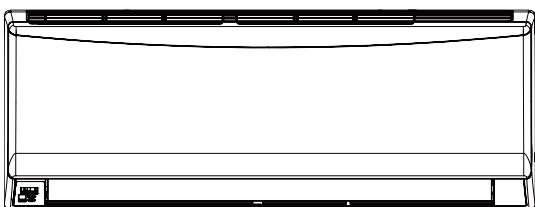

D6 panel

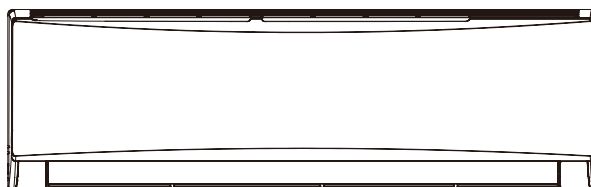

GWH18QD-K6DND2D/I(CB461N05701)
GWH24QE-K6DND2E/I (CB461N05601)
GWH12QC-K6DND2D/I(CB461N05501)
GWH09QC-K6DND2A/I(CB461N06600)
GWH12QC-K6DND2A/I(CB461N06500)
GWH18QD-K6DND2A/I(CB461N06700)
GWH24QE-K6DND2I/I(CB461N06800)

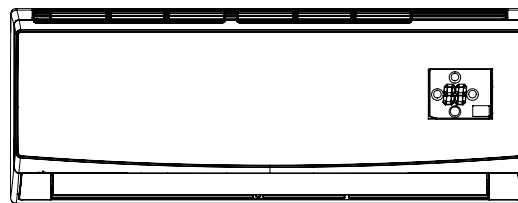

C8 panel

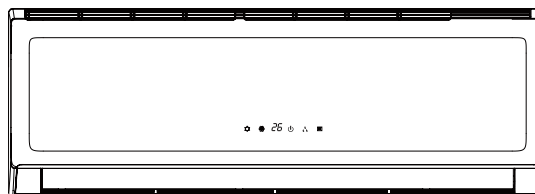

Outdoor Unit

GWH12QC-K6DNA1D/O
 GWH09YC-K6DNA1A/O
 GWH12YC-K6DNA1A/O
 GWH12QC-K6DNA5X/O

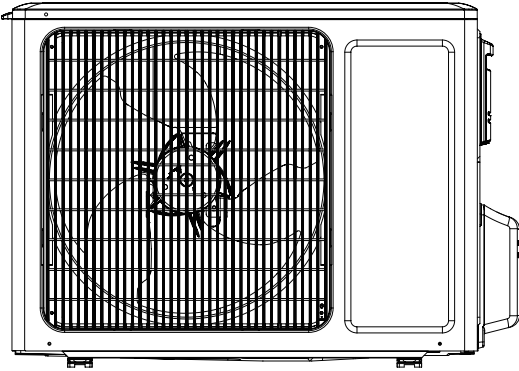

GWH18QD-K6DNA1D/O GWH18QD-K6DNA5X/O
 GWH24QE-K6DNA1E/O GWH24QE-K6DNA5X/O
 GWH24YE-K6DNA1A/O

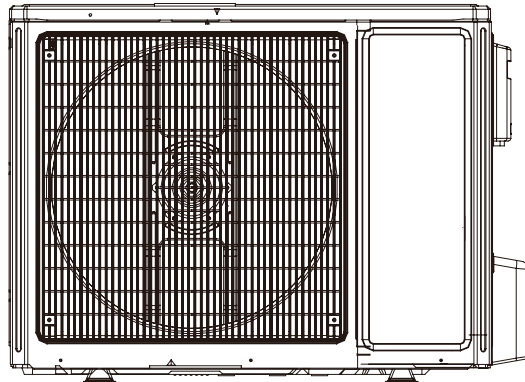

GWH09QB-K6DNA1E/O

GWH18YD-K6DNA1A/O(CB437W01300)

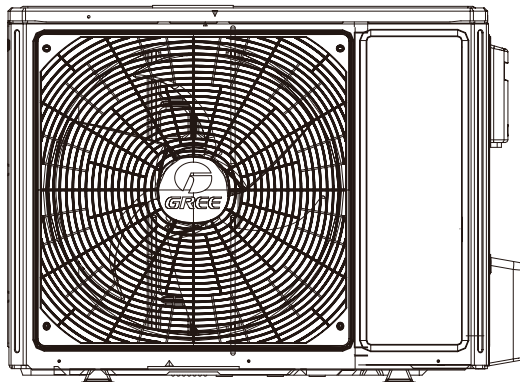
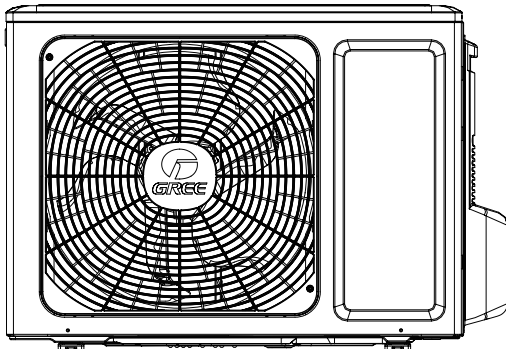

GWH09AGA-K6DNA1A/O
 GWH12AGB-K6DNA1A/O

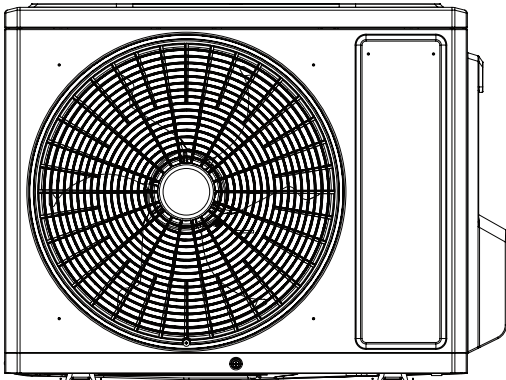

Remote Controller

YAC1FB9(WiFi)

YAG1FB2(WiFi)

YAA1FB8(WiFi)

YAN1F6(WiFi)



Model List:

No	Model	Product code	Indoor model	Indoor product code	Outdoor model	Outdoor product code	Remote Controller			
1	GWH09QB-K6DNA1E	CB419015801	GWH09QB-K6DNA1E/I	CB419N15800	GWH09QB-K6DNA1E/O	CB419W15801				
2	GWH09QB-K6DNA3E	CB424008001	GWH09QB-K6DNA3E/I	CB424N08000						
3	GWH09QB-K6DNA5E	CB425012501	GWH09QB-K6DNA5E/I	CB425N12500						
4	GWH09QB-K6DNC4E	CB444009601	GWH09QB-K6DNC4E/I	CB444N09600						
5	GWH09QB-K6DNC4E	CB444009602	GWH09QB-K6DNC4E/I	CB444N09602						
6	GWH09QB-K6DNE4E	CB470002701	GWH09QB-K6DNE4E/I	CB470N02700						
7		CB470002703		CB470N02702						
8	GWH09QB-K6DNB6E	CB435009601	GWH09QB-K6DNB6E/I	CB435N09600						
9	GWH09QB-K6DNC6E	CB443006001	GWH09QB-K6DNC6E/I	CB443N06000						
10	GWH09QB-K6DNB2E	CB432017601	GWH09QB-K6DNB2E/I	CB432N17601						
11	GWH09QB-K6DNB4E	CB434012302	GWH09QB-K6DNB4E/I	CB434N12302						
12	GWH09QB-K6DNA2E	CB426007601	GWH09QB-K6DNA2E/I	CB426N07600						
13	GWH09QB-K6DNC6E	CB443006003	GWH09QB-K6DNC6E/I	CB443N06002						
14	GWH09QB-K6DNB8E	CB438010101	GWH09QB-K6DNB8E/I	CB438N10101						
15	GWH09QB-K6DNA1E	CB419015800	GWH09QB-K6DNA1E/I	CB419N15800				GWH09QB-K6DNA1E/O	CB419W15800	YAC1FB9 (WiFi)
16	GWH09QB-K6DNA5E	CB425012500	GWH09QB-K6DNA5E/I	CB425N12500						
17		CB425012502		CB425N12502						
18	GWH09QB-K6DNB6E	CB435009600	GWH09QB-K6DNB6E/I	CB435N09600						
19	GWH09QB-K6DNC2E	CB439013300	GWH09QB-K6DNC2E/I	CB439N13300						
20	GWH09QB-K6DNB2E	CB432017600	GWH09QB-K6DNB2E/I	CB432N17600						
21		CB432017602		CB432N17602						
22	GWH09QB-K6DNE4E	CB470002700	GWH09QB-K6DNE4E/I	CB470N02700						
23	GWH09QB-K6DNB4E	CB434012300	GWH09QB-K6DNB4E/I	CB434N12300						
24	GWH09QB-K6DNB8E	CB438010100	GWH09QB-K6DNB8E/I	CB438N10100						
25	GWH09QB-K6DNE4E	CB470002702	GWH09QB-K6DNE4E/I	CB470N02702						
26	GWH09QB-K6DNC6E	CB443006002	GWH09QB-K6DNC6E/I	CB443N06002						
27	GWH09QB-K6DND6E	CB460005900	GWH09QB-K6DND6E/I	CB460N05900						
28	GWH09QB-K6DND2E	CB461005800	GWH09QB-K6DND2E/I	CB461N05800						
29	GWH09QB-K6DND2E	CB461005802	GWH09QB-K6DND2E/I	CB461N05802						
30	GWH09QB-K6DND2E	CB461005801	GWH09QB-K6DND2E/I	CB461N05801						
31	GWH09QC-K6DNC2A	CB439014100	GWH09QC-K6DNC2A/I	CB439N14100	GWH09YC-K6DNA1A/O	CB437W01600				
32	GWH09QC-K6DND2A	CB461006600	GWH09QC-K6DND2A/I	CB461N06600						
33	GWH12QC-K6DNC2A	CB439014200	GWH12QC-K6DNC2A/I	CB439N14200	GWH12YC-K6DNA1A/O	CB437W01100	YAG1FB2 (WiFi)			
34	GWH12QC-K6DND2A	CB461006500	GWH12QC-K6DND2A/I	CB461N06500						
35	GWH18QD-K6DND2A	CB461006700	GWH18QD-K6DND2A/I	CB461N06700	GWH18YD-K6DNA1A/O	CB437W01300				
36	GWH24QE-K6DND2I	CB461006800	GWH24QE-K6DND2I/I	CB461N06800	GWH24YE-K6DNA1A/O	CB437W01400				
37	GWH12QC-K6DNA1D	CB419015501	GWH12QC-K6DNA1D/I	CB419N15500	GWH12QC-K6DNA1D/O	CB419W15501				
38	GWH12QC-K6DNA3D	CB424008201	GWH12QC-K6DNA3D/I	CB424N08200						
39	GWH12QC-K6DNE4D	CB470002901	GWH12QC-K6DNE4D/I	CB470N02900						
40	GWH12QC-K6DNA5D	CB425012301	GWH12QC-K6DNA5D/I	CB425N12300						
41	GWH12QC-K6DNC6D	CB443005701	GWH12QC-K6DNC6D/I	CB443N05700						
42	GWH12QC-K6DNB6D	CB435009401	GWH12QC-K6DNB6D/I	CB435N09400						
43	GWH12QC-K6DNC8D	CB456007101	GWH12QC-K6DNC8D/I	CB456N07100						
44	GWH12QC-K6DNB2D	CB432017801	GWH12QC-K6DNB2D/I	CB432N17801						
45	GWH12QC-K6DNB4D	CB434012601	GWH12QC-K6DNB4D/I	CB434N12601						
46	GWH12QC-K6DNC6D	CB443005703	GWH12QC-K6DNC6D/I	CB443N05702						
47	GWH12QC-K6DNB8D	CB438010202	GWH12QC-K6DNB8D/I	CB438N10202						
48	GWH12QC-K6DND2D	CB461005503	GWH12QC-K6DND2D/I	CB461N05501						
49	GWH12QC-K6DNB6D	CB435009400	GWH12QC-K6DNB6D/I	CB435N09400				GWH12QC-K6DNA1D/O	CB419W15500	YAC1FB9 (WiFi)
50	GWH12QC-K6DNA5D	CB425012300	GWH12QC-K6DNA5D/I	CB425N12300						
51		CB425012302		CB425N12302						
52	GWH12QC-K6DNC2D	CB439013100	GWH12QC-K6DNC2D/I	CB439N13100						
53	GWH12QC-K6DNB4D	CB434012600	GWH12QC-K6DNB4D/I	CB434N12600						
54	GWH12QC-K6DNB2D	CB432017800	GWH12QC-K6DNB2D/I	CB432N17800						
55		CB432017802		CB432N17802						
56	GWH12QC-K6DNE4D	CB470002900	GWH12QC-K6DNE4D/I	CB470N02900						
57	GWH12QC-K6DNA1D	CB419015500	GWH12QC-K6DNA1D/I	CB419N15500						
58	GWH12QC-K6DNB8D	CB438010200	GWH12QC-K6DNB8D/I	CB438N10200						
59		CB438010201		CB438N10201						
60	GWH12QC-K6DNE4D	CB470002902	GWH12QC-K6DNE4D/I	CB470N02902						
61	GWH12QC-K6DNC6D	CB443005702	GWH12QC-K6DNC6D/I	CB443N05702						
62	GWH12QC-K6DND2D	CB461005500	GWH12QC-K6DND2D/I	CB461N05500						
63	GWH12QC-K6DND2D	CB461005501	GWH12QC-K6DND2D/I	CB461N05501						
64	GWH12QC-K6DND2D	CB461005502	GWH12QC-K6DND2D/I	CB461N05502						
65	GWH12QC-K6DND6D	CB460006700	GWH12QC-K6DND6D/I	CB460N06700						

66	GWH18QD-K6DNA1D	CB419015601	GWH18QD-K6DNA1D/I	CB419N15600	GWH18QD-K6DNA1D/O	CB419W15601	
67	GWH18QD-K6DNA3D	CB424008101	GWH18QD-K6DNA3D/I	CB424N08100			
68	GWH18QD-K6DNA5D	CB425012401	GWH18QD-K6DNA5D/I	CB425N12400			
69	GWH18QD-K6DNC4D	CB444012301	GWH18QD-K6DNC4D/I	CB444N12300			
70	GWH18QD-K6DNC6D	CB443005801	GWH18QD-K6DNC6D/I	CB443N05800			
71	GWH18QD-K6DNB6D	CB435009501	GWH18QD-K6DNB6D/I	CB435N09500			
72	GWH18QD-K6DNB2D	CB432017901	GWH18QD-K6DNB2D/I	CB432N17901			
73	GWH18QD-K6DNB2D	CB432017902	GWH18QD-K6DNB2D/I	CB432N17900			
74	GWH18QD-K6DNC6D	CB443005803	GWH18QD-K6DNC6D/I	CB443N05802			
75	GWH18QD-K6DNB4D	CB434012501	GWH18QD-K6DNB4D/I	CB434N12501			
76	GWH18QD-K6DNB8D	CB438010301	GWH18QD-K6DNB8D/I	CB438N10301			
77	GWH18QD-K6DNA5D	CB425012400	GWH18QD-K6DNA5D/I	CB425N12400	GWH18QD-K6DNA1D/O	CB419W15600	
78		CB425012402		CB425N12402			
79	GWH18QD-K6DNB6D	CB435009500	GWH18QD-K6DNB6D/I	CB435N09500			
80	GWH18QD-K6DNB2D	CB432017900	GWH18QD-K6DNB2D/I	CB432N17900			
81	GWH18QD-K6DNC2E	CB439013200	GWH18QD-K6DNC2E/I	CB439N13200			
82	GWH18QD-K6DNE4D	CB470003000	GWH18QD-K6DNE4D/I	CB470N03000			
83	GWH18QD-K6DNE4D	CB470003001	GWH18QD-K6DNE4D/I	CB470N03001			
84	GWH18QD-K6DNB8D	CB438010300	GWH18QD-K6DNB8D/I	CB438N10300			
85	GWH18QD-K6DNB4D	CB434012500	GWH18QD-K6DNB4D/I	CB434N12500			
86	GWH18QD-K6DNA1D	CB419015600	GWH18QD-K6DNA1D/I	CB419N15600			
87	GWH18QD-K6DNC6D	CB443005802	GWH18QD-K6DNC6D/I	CB443N05802			
88	GWH18QD-K6DND2D	CB461005702	GWH18QD-K6DND2D/I	CB461N05702	GWH24QE-K6DNA1E/O	CB419W15700	YAC1FB9 (WiFi)
89		CB461005701		CB461N05701			
90		CB461005700		CB461N05700			
91	GWH18QD-K6DND6D	CB460006600	GWH18QD-K6DND6D/I	CB460N06600			
92	GWH24QE-K6DNA1E	CB419015700	GWH24QE-K6DNA1E/I	CB419N15700			
93	GWH24QE-K6DNC2E	CB439013000	GWH24QE-K6DNC2E/I	CB439N13000			
94	GWH24QE-K6DNB6E	CB435009300	GWH24QE-K6DNB6E/I	CB435N09300			
95	GWH24QE-K6DNA5E	CB425012200	GWH24QE-K6DNA5E/I	CB425N12200			
96		CB425012203		CB425N12203			
97	GWH24QE-K6DNB4E	CB434012400	GWH24QE-K6DNB4E/I	CB434N12400			
98	GWH24QE-K6DND2E	CB461005602	GWH24QE-K6DND2E/I	CB461N05602			
99		CB461005601		CB461N05601			
100		CB461005600		CB461N05600			
101	GWH24QE-K6DNB2E	CB432017700	GWH24QE-K6DNB2E/I	CB432N17700			
102	GWH24QE-K6DNC4E	CB444009800	GWH24QE-K6DNC4E/I	CB444N09800			
103	GWH24QE-K6DNE4E	CB470002800	GWH24QE-K6DNE4E/I	CB470N02800			
104	GWH24QE-K6DNB8E	CB438010400	GWH24QE-K6DNB8E/I	CB438N10400			
105	GWH24QE-K6DNE4E	CB470002801	GWH24QE-K6DNE4E/I	CB470N02801			
106	GWH24QE-K6DNC6E	CB443005903	GWH24QE-K6DNC6E/I	CB443N05903			
107	GWH24QE-K6DND6E	CB460006500	GWH24QE-K6DND6E/I	CB460N06500			
108	GWH24QE-K6DNA1E	CB419015701	GWH24QE-K6DNA1E/I	CB419N15700			
109	GWH24QE-K6DNA5E	CB425012201	GWH24QE-K6DNA5E/I	CB425N12200			
110	GWH24QE-K6DNB4E	CB434012402	GWH24QE-K6DNB4E/I	CB434N12402			
111	GWH24QE-K6DNC6E	CB443005902	GWH24QE-K6DNC6E/I	CB443N05902			
112	GWH24QE-K6DNA5E	CB425012202	GWH24QE-K6DNA5E/I	CB425N12202			
113	GWH24QE-K6DNC6E	CB443005901	GWH24QE-K6DNC6E/I	CB443N05900			
114	GWH24QE-K6DNB6E	CB435009301	GWH24QE-K6DNB6E/I	CB435N09300			
115	GWH24QE-K6DNC4E	CB444009801	GWH24QE-K6DNC4E/I	CB444N09801			
116	GWH24QE-K6DNB2E	CB432017701	GWH24QE-K6DNB2E/I	CB432N17701			
117	GWH24QE-K6DNB2E	CB432017702	GWH24QE-K6DNB2E/I	CB432N17700			
118	GWH24QE-K6DNC6E	CB443005904	GWH24QE-K6DNC6E/I	CB443N05903			
119	GWH24QE-K6DNB8E	CB438010401	GWH24QE-K6DNB8E/I	CB438N10401			
120	GWH24QE-K6DNB4E	CB434012403	GWH24QE-K6DNB4E/I	CB434N12403			
121	GWH24QE-K6DNC2E	CB439013001	GWH24QE-K6DNC2E/I	CB439N13001	GWH24QE-K6DNA1E/O	CB419W15700	YAA1FB8 (WiFi)
122	GWH18QD-K6DNA5X	CB425015300	GWH18QD-K6DNA5X/I	CB425N15300	GWH18QD-K6DNA5X/O	CB425W15300	YAC1FB9 (WiFi)
123	GWH24QE-K6DNA5X	CB425015400	GWH24QE-K6DNA5X/I	CB425N15400	GWH24QE-K6DNA5X/O	CB425W15400	
124	GWH12QC-K6DNA5X	CB425015500	GWH12QC-K6DNA5X/I	CB425N15500	GWH12QC-K6DNA5X/O	CB425W15500	
125	GWH09QA-K6DNB2A	CB432025400	GWH09QA-K6DNB2A/I	CB432N25400	GWH09AGA-K6DNA1A/O	CB385W01000	YAN1F6 (WiFi)
126	GWH12QB-K6DNB2A	CB432025500	GWH12QB-K6DNB2A/I	CB432N25500	GWH12AGB-K6DNA1A/O	CB385W01700	

2. Specifications

2.1 Specification Sheet

Model			1.GWH09QB-K6DNA1E 2.GWH09QB-K6DNA5E 3.GWH09QB-K6DNC4E 4.GWH09QB-K6DNE4E 5.GWH09QB-K6DNB6E 6.GWH09QB-K6DNC6E 7.GWH09QB-K6DNA3E 8.GWH09QB-K6DNB2E 9.GWH09QB-K6DNB4E 10.GWH09QB-K6DNA2E 11.GWH09QB-K6DNB8E	GWH09QB-K6DNC4E GWH09QB-K6DNE4E	
Product Code			1.CB419015801 2.CB425012501 3.CB444009601 4.CB470002701 5.CB435009601 6.CB443006001/ CB443006003 7.CB424008001 8.CB432017601 9.CB434012302 10.CB426007601 11.CB438010101	CB444009602 CB470002703	
Power Supply	Rated Voltage	V~	220-240	220-240	
	Rated Frequency	Hz	50	50	
	Phases		1	1	
Power Supply Mode			Outdoor	Outdoor	
Cooling Capacity		W	2700	2700	
Heating Capacity		W	2800	2800	
Cooling Power Input		W	820	820	
Heating Power Input		W	755	755	
Cooling Current Input		A	3.8	3.8	
Heating Current Input		A	3.5	3.5	
Rated Input		W	1500	1500	
Rated Current		A	3.8	3.8	
Air Flow Volume(SS/H/MH/M/ML/L/SL)		m ³ /h	560/490/460/430/380/330/290	560/490/460/430/380/330/290	
Dehumidifying Volume		L/h	0.8	0.8	
EER		W/W	3.29	3.29	
COP		W/W	3.71	3.71	
SEER			6.8	6.8	
SCOP(Average/Warmer/Colder)			4/5.1/3.2	4/5.1/3.2	
Application Area		m ²	12-18	12-18	
Indoor Unit	Indoor Unit Model		1.GWH09QB-K6DNA1E/I 2.GWH09QB-K6DNA5E/I 3.GWH09QB-K6DNC4E/I 4.GWH09QB-K6DNE4E/I 5.GWH09QB-K6DNB6E/I 6.GWH09QB-K6DNC6E/I 7.GWH09QB-K6DNA3E/I 8.GWH09QB-K6DNB2E/I 9.GWH09QB-K6DNB4E/I 10.GWH09QB-K6DNA2E/I	GWH09QB-K6DNC4E/I GWH09QB-K6DNE4E/I	
	Fan Type		Cross-flow	Cross-flow	
	Fan Diameter Length(DXL)		mm	φ98X580	φ98X580
	Cooling Speed(SS/H/MH/M/ML/L/SL)		r/min	1350/1200/1120/1050/920/800/750	1350/1200/1120/1050/920/800/750
	Heating Speed(SS/H/MH/M/ML/L/SL)		r/min	1300/1200/1120/1050/950/850/800	1300/1200/1120/1050/950/850/800
	Fan Motor Power Output		W	20	20
	Fan Motor RLA		A	0.215	0.215
	Fan Motor Capacitor		μF	1	1
	Evaporator Form			Aluminum Fin-copper Tube	Aluminum Fin-copper Tube
	Evaporator Pipe Diameter		mm	Φ5	Φ5
	Evaporator Row-fin Gap		mm	2-1.4	2-1.4
	Evaporator Coil Length(LDXW)		mm	584X22.8X266.7	584X22.8X266.7
	Swing Motor Model			MP24AA/MP24HF	MP24AA
	Swing Motor Power Output		W	1.5/1.5	1.5
	Fuse Current		A	3.15	3.15
	Sound Pressure Level(SS/H/MH/M/ML/L/SL)		dB (A)	41/37/35/32/29/26/24	41/37/35/32/29/26/24
	Sound Power Level(SS/H/MH/M/ML/L/SL)		dB (A)	55/48/46/44/40/37/35	55/48/46/44/40/37/35
	Dimension(WXHXD)		mm	790X275X200	790X275X200
	Dimension of Carton Box(LXWXH)		mm	863X268X352	863X268X352
	Dimension of Package(LXWXH)		mm	866X271X367	866X271X367
Net Weight		kg	9	9	
Gross Weight		kg	11	11	

Outdoor Unit	Model of Outdoor Unit		GWH09QB-K6DNA1E/O
	Product Code of Outdoor Unit		CB419W15801
	Compressor Manufacturer/Trademark		ZHUHAI LANDA COMPRESSOR CO., LTD
	Compressor Model		QXF-A079zE190A
	Compressor Oil		FW68DA
	Compressor Type		Rotary
	L.R.A.	A	/
	Compressor RLA	A	4.6
	Compressor Power Input	W	790
	Overload Protector		HPC115/95U1/KSD115°C
	Throttling Method		Capillary
	Operation temp	°C	16~30
	Ambient temp (cooling)	°C	-15~43
	Ambient temp (heating)	°C	-15~24
	Condenser Form		Aluminum Fin-copper Tube
	Pipe Diameter	mm	Φ7
	Rows-fin Gap	mm	1-1.4
	Coil Length (LXDXW)	mm	710X19.05X508
	Fan Motor Speed	rpm	900
	Output of Fan Motor	W	30
	Fan Motor RLA	A	0.36
	Fan Motor Capacitor	μF	/
	Air Flow Volume of Outdoor Unit	m ³ /h	1600
	Fan Type		Axial-flow
	Fan Diameter	mm	Φ400
	Defrosting Method		Automatic Defrosting
	Climate Type		T1
	Isolation		I
	Moisture Protection		IPX4
	Permissible Excessive Operating Pressure for the Discharge Side	MPa	4.3
	Permissible Excessive Operating Pressure for the Suction Side	MPa	2.5
	Sound Pressure Level (H/M/L)	dB (A)	50/-/-
	Sound Power Level (H/M/L)	dB (A)	59/-/-
Dimension (WXHXD)	mm	782X540X320	
Dimension of Carton Box (LXWXH)	mm	820X355X580	
Dimension of Package (LXWXH)	mm	823X358X595	
Net Weight	kg	27.5	
Gross Weight	kg	30	
Refrigerant		R32	
Refrigerant Charge	kg	0.55	
Connection Pipe	Length	m	5
	Gas Additional Charge	g/m	16
	Outer Diameter Liquid Pipe	mm	Φ6
	Outer Diameter Gas Pipe	mm	Φ9.52
	Max Distance Height	m	10
	Max Distance Length	m	15
	Note: The connection pipe applies metric diameter.		

The above data is subject to change without notice; please refer to the nameplate of the unit.

Model		GWH09QB-K6DNE4E GWH09QB-K6DNA5E	1.GWH09QB-K6DNA1E 2.GWH09QB-K6DNA5E 3.GWH09QB-K6DNB6E 4.GWH09QB-K6DNC2E 5.GWH09QB-K6DNB2E 6.GWH09QB-K6DNC6E 7.GWH09QB-K6DNE4E 8.GWH09QB-K6DNB4E 9.GWH09QB-K6DNB8E 10.GWH09QB-K6DND6E 11.GWH09QB-K6DND2E	
Product Code		CB470002702 CB425012502	1.CB419015800 2.CB425012500 3.CB435009600 4.CB439013300 5.CB432017600/CB432017602 6.CB443006002 7.CB470002700 8.CB434012300 9.CB438010100 10.CB460005900 11. (CB461005800/CB461005802 /CB461005801)	
Power Supply	Rated Voltage	V~	220-240	220-240
	Rated Frequency	Hz	50	50
	Phases		1	1
Power Supply Mode		Outdoor	Outdoor	Outdoor
Cooling Capacity	W	2700	2700	2700
Heating Capacity	W	2800	2800	2800
Cooling Power Input	W	820	820	820
Heating Power Input	W	755	755	755
Cooling Current Input	A	3.8	3.8	3.8
Heating Current Input	A	3.5	3.5	3.5
Rated Input	W	1500	1500	1500
Rated Current	A	3.8	3.8	3.8
Air Flow Volume(SS/H/MH/M/ML/L/SL)	m ³ /h	560/490/460/430/380/330/290	560/490/460/430/380/330/290	560/490/460/430/380/330/290
Dehumidifying Volume	L/h	0.8	0.8	0.8
EER	W/W	3.29	3.29	3.29
COP	W/W	3.71	3.71	3.71
SEER		6.8	6.8	6.8
SCOP(Average/Warmer/Colder)		4/5.1/3.2	4/5.1/3.2	4/5.1/3.2
Application Area	m ²	12-18	12-18	12-18
Application Area	Fan Type		Cross-flow	Cross-flow
	Fan Diameter Length(DXL)	mm	Φ98X580	Φ98X580
	Cooling Speed(SS/H/MH/M/ML/L/SL)	r/min	1350/1200/1120/1050/920/800/750	1350/1200/1120/1050/920/800/750
	Heating Speed(SS/H/MH/M/ML/L/SL)	r/min	1300/1200/1120/1050/950/850/800	1300/1200/1120/1050/950/850/800
	Fan Motor Power Output	W	20	20
	Fan Motor RLA	A	0.215	0.215
	Fan Motor Capacitor	μF	1	1
	Evaporator Form		Aluminum Fin-copper Tube	Aluminum Fin-copper Tube
	Evaporator Pipe Diameter	mm	Φ5	Φ5
	Evaporator Row-fin Gap	mm	2-1.4	2-1.4
	Evaporator Coil Length(LXDXW)	mm	584X22.8X266.7	584X22.8X266.7
	Swing Motor Model		MP24AA	MP24AA/MP24HF
	Swing Motor Power Output	W	1.5	1.5/1.5
	Fuse Current	A	3.15	3.15
	Sound Pressure Level(SS/H/MH/M/ML/L/SL)	dB (A)	41/37/35/32/29/26/24	41/37/35/32/29/26/24
	Sound Power Level(SS/H/MH/M/ML/L/SL)	dB (A)	55/48/46/44/40/37/35	55/48/46/44/40/37/35
	Dimension(WXHXD)	mm	790X275X200	790X275X200
	Dimension of Carton Box(LXWXH)	mm	863X268X352	863X268X352
	Dimension of Package(LXWXH)	mm	866X271X367	866X271X367
	Net Weight	kg	9	9
	Gross Weight	kg	11	11

Outdoor Unit	Model of Outdoor Unit		GWH09QB-K6DNA1E/O
	Product Code of Outdoor Unit		CB419W15800
	Compressor Manufacturer/Trademark		ZHUHAI LANDA COMPRESSOR CO., LTD
	Compressor Model		QXF-A079zE190A
	Compressor Oil		FW68DA
	Compressor Type		Rotary
	L.R.A.	A	/
	Compressor RLA	A	4.6
	Compressor Power Input	W	790
	Overload Protector		HPC115/95U1/KSD115°C
	Throttling Method		Capillary
	Operation temp	°C	16~30
	Ambient temp (cooling)	°C	-15~43
	Ambient temp (heating)	°C	-22~24
	Condenser Form		Aluminum Fin-copper Tube
	Pipe Diameter	mm	Φ7
	Rows-fin Gap	mm	1-1.4
	Coil Length (LXDXW)	mm	710X19.05X508
	Fan Motor Speed	rpm	900
	Output of Fan Motor	W	30
	Fan Motor RLA	A	0.36
	Fan Motor Capacitor	μF	/
	Air Flow Volume of Outdoor Unit	m ³ /h	1600
	Fan Type		Axial-flow
	Fan Diameter	mm	Φ400
	Defrosting Method		Automatic Defrosting
	Climate Type		T1
	Isolation		I
	Moisture Protection		IPX4
	Permissible Excessive Operating Pressure for the Discharge Side	MPa	4.3
	Permissible Excessive Operating Pressure for the Suction Side	MPa	2.5
	Sound Pressure Level (H/M/L)	dB (A)	50/-/-
	Sound Power Level (H/M/L)	dB (A)	59/-/-
Dimension (WXHDXD)	mm	782X540X320	
Dimension of Carton Box (LXWXH)	mm	820X355X580	
Dimension of Package (LXWXH)	mm	823X358X595	
Net Weight	kg	27.5	
Gross Weight	kg	30	
Refrigerant		R32	
Refrigerant Charge	kg	0.55	
Connection Pipe	Length	m	5
	Gas Additional Charge	g/m	16
	Outer Diameter Liquid Pipe	mm	Φ6
	Outer Diameter Gas Pipe	mm	Φ9.52
	Max Distance Height	m	10
	Max Distance Length	m	15
	Note: The connection pipe applies metric diameter.		

The above data is subject to change without notice; please refer to the nameplate of the unit.

Model			GWH09QC-K6DNC2A GWH09QC-K6DND2A	GWH12QC-K6DNC2A GWH12QC-K6DND2A
Product Code			CB439014100 CB461006600	CB439014200 CB461006500
Power Supply	Rated Voltage	V~	220-240	220-240
	Rated Frequency	Hz	50	50
	Phases		1	1
Power Supply Mode			Outdoor	Outdoor
Cooling Capacity		W	2700	3500
Heating Capacity		W	2930	3810
Cooling Power Input		W	585	950
Heating Power Input		W	650	975
Cooling Current Input		A	2.6	4.0
Heating Current Input		A	2.9	4.5
Rated Input		W	1650	1650
Rated Current		A	6.4	6.4
Air Flow Volume(SH/H/MH/M/ML/L/SL)		m ³ /h	560/490/460/430/380/330/290	680/590/540/490/450/420/390
Dehumidifying Volume		L/h	0.8	1.4
EER		W/W	4.62	3.68
COP		W/W	4.51	3.91
SEER		W/W	8.5	8.5
SCOP(Average/Warmer/Colder)		W/W	4.6/5.4/3.8	4.4/5.1/3.5
Application Area		m ²	12-18	16-24
Indoor Unit	Indoor Unit Model		GWH09QC-K6DNC2A/I GWH09QC-K6DND2A/I	GWH12QC-K6DNC2A/I GWH12QC-K6DND2A/I
	Indoor Unit Product Code		CB439N14100 CB461N06600	CB439N14200 CB461N06500
	Fan Type		Cross-flow	Cross-flow
	Fan Diameter Length(DXL)		mm	Φ98X633.5
	Cooling Speed		r/min	1300/1200/1120/1050/980/920/750
	Heating Speed		r/min	1300/1200/1140/1080/1020/960/900
	Fan Motor Power Output		W	20
	Fan Motor RLA		A	0.09
	Fan Motor Capacitor		μF	/
	Evaporator Form			Aluminum Fin-copper Tube
	Evaporator Pipe Diameter		mm	Φ5
	Evaporator Row-fin Gap		mm	2-1.4
	Evaporator Coil Length (LXDXW)		mm	635X22.8X306.3
	Swing Motor Model			MP24EB/MP24HF
	Swing Motor Power Output		W	1.5/1.5
	Fuse Current		A	3.15
	Sound Pressure Level(SH/H/MH/M/ML/L/SL)		dB (A)	41/39/37/35/33/31/24
	Sound Power Level(SH/H/MH/M/ML/L/SL)		dB (A)	56/53/52/50/48/46/39
	Dimension (WXHXD)		mm	845X289X209
	Dimension of Carton Box (LXWXH)		mm	918X278/364
Dimension of Package(LXWXH)		mm	931X281X379	
Net Weight		kg	10.5	
Gross Weight		kg	12.5	

Outdoor Unit	Outdoor Unit Model		GWH09YC-K6DNA1A/O	GWH12YC-K6DNA1A/O
	Outdoor Unit Product Code		CB437W01600	CB437W01100
	Compressor Manufacturer		ZHUHAI LANDA COMPRESSOR CO.,LTD	ZHUHAI LANDA COMPRESSOR CO., LTD
	Compressor Model		QXF-B096zE190A	QXF-B096zE190A
	Compressor Oil		FW68DA	FW68DA
	Compressor Type		Rotary	Rotary
	Compressor LRA	A	20.00	20
	Compressor RLA	A	4.21	4.21
	Compressor Power Input	W	943	943
	Compressor Overload Protector		1NT11L-6233 HPC115/95U1 KSD115°C	1NT11L-6233 HPC115/95U1 KSD115°C
	Throttling Method		Electron expansion valve	Electron expansion valve
	Set Temperature Range	°C	16~30	16~30
	Cooling Operation Ambient Temperature Range	°C	-15~43	-15~43
	Heating Operation Ambient Temperature Range	°C	-15~24	-15~24
	Condenser Form		Aluminum Fin-copper Tube	Aluminum Fin-copper Tube
	Condenser Pipe Diameter	mm	Φ7	Φ7
	Condenser Rows-fin Gap	mm	2-1.4	2-1.4
	Condenser Coil Length (LXDXW)	mm	742X38.1X550	742X38.1X550
	Fan Motor Speed	rpm	900/650	900/650
	Fan Motor Power Output	W	30	30
	Fan Motor RLA	A	0.36	0.36
	Fan Motor Capacitor	μF	/	/
	Outdoor Unit Air Flow Volume	m ³ /h	2200	2200
	Fan Type		Axial-flow	Axial-flow
	Fan Diameter	mm	Φ438	Φ438
	Defrosting Method		Automatic Defrosting	Automatic Defrosting
	Climate Type		T1	T1
	Isolation		I	I
	Moisture Protection		IPX4	IPX4
	Permissible Excessive Operating Pressure for the Discharge Side	MPa	4.3	4.3
	Permissible Excessive Operating Pressure for the Suction Side	MPa	2.5	2.5
	Sound Pressure Level (H/M/L)	dB (A)	52/-/-	53/-/-
Sound Power Level (H/M/L)	dB (A)	60/-/-	62/-/-	
Dimension(WXHXD)	mm	848X596X320	848X596X320	
Dimension of Carton Box (LXWXH)	mm	878X360X630	878X360X630	
Dimension of Package(LXWXH)	mm	881X363X645	881X363X645	
Net Weight	kg	33.5	33.5	
Gross Weight	kg	36.5	36.5	
Refrigerant		R32	R32	
Refrigerant Charge	kg	0.7	0.75	
Connection Pipe	Connection Pipe Length	m	5	5
	Connection Pipe Gas Additional Charge	g/m	16	16
	Outer Diameter Liquid Pipe	mm	Φ6	Φ6
	Outer Diameter Gas Pipe	mm	Φ9.52	Φ9.52
	Max Distance Height	m	10	10
	Max Distance Length	m	15	20
Note: The connection pipe applies metric diameter.				

The above data is subject to change without notice. Please refer to the nameplate of the unit.

Parameter	Unit	Value
Model		GWH18QD-K6DND2A
Product Code		CB461006700
Power Supply	Rated Voltage	V ~
	Rated Frequency	Hz
	Phases	
Power Supply Mode		Outdoor
Cooling Capacity(Min~Max)	W	5300
Heating Capacity(Min~Max)	W	5570
Cooling Power Input(Min~Max)	W	1550
Heating Power Input(Min~Max)	W	1428
Cooling Current Input	A	6.9
Heating Current Input	A	6.3
Rated Input	W	2600
Rated Current	A	10.9
Air Flow Volume(SH/MH/H/M//ML/L/SL)	m ³ /h	850/-/750/610/-/520/-
Dehumidifying Volume	L/h	1.80
EER	W/W	3.42
COP	W/W	3.90
SEER	W/W	7.60
SCOP (Average/Warmer/Colder)		4.10/5.20/3.40
HSPF	W/W	/
Application Area	m ²	23-34
Indoor Unit	Indoor Unit Model	
	Indoor Unit Product Code	
	Fan Type	
	Fan Diameter Length(DXL)	mm
	Cooling Speed(SH/MH/H/M//ML/L/SL)	r/min
	Heating Speed(SH/MH/H/M//ML/L/SL)	r/min
	Fan Motor Power Output	W
	Fan Motor RLA	A
	Fan Motor Capacitor	μF
	Evaporator Form	
	Evaporator Pipe Diameter	mm
	Evaporator Row-fin Gap	mm
	Evaporator Coil Length (LXDXW)	mm
	Swing Motor Model	
	Swing Motor Power Output	W
	Fuse Current	A
	Sound Pressure Level(SH/H/MH/M/ML/L/SL)	dB (A)
	Sound Power Level(SH/H/MH/M/ML/L/SL)	dB (A)
	Dimension (WXHXD)	mm
	Dimension of Carton Box (LXWXH)	mm
Dimension of Package(LXWXH)	mm	
Net Weight	kg	
Gross Weight	kg	

Outdoor Unit	Outdoor Unit Model		GWH18YD-K6DNA1A/O	
	Outdoor Unit Product Code		CB437W01300	
	Compressor Manufacturer		ZHUHAI LANDA COMPRESSOR CO.,LTD	
	Compressor Model		QXF-B141zF030A	
	Compressor Oil		68EP	
	Compressor Type		Rotary	
	Compressor LRA.	A		25
	Compressor RLA	A		6.5
	Compressor Power Input	W		1410
	Compressor Overload Protector			1NT11L-6233
	Throttling Method			Electronic Expansion Valve
	Set Temperature Range	°C		16~30
	Cooling Operation Ambient Temperature Range	°C		-15~43
	Heating Operation Ambient Temperature Range	°C		-15~24
	Condenser Form			Aluminum Fin-copper Tube
	Condenser Pipe Diameter	mm		Φ7
	Condenser Rows-fin Gap	mm		2-1.4
	Condenser Coil Length (LXDXW)	mm		851X38.1X660
	Fan Motor Speed	rpm		800
	Fan Motor Power Output	W		60
	Fan Motor RLA	A		0.65
	Fan Motor Capacitor	μF		/
	Outdoor Unit Air Flow Volume	m ³ /h		3200
	Fan Type			Axial-flow
	Fan Diameter	mm		Φ520
	Defrosting Method			Automatic Defrosting
	Climate Type			T1
	Isolation			I
	Moisture Protection			IPX4
	Permissible Excessive Operating Pressure for the Discharge Side	MPa		4.3
	Permissible Excessive Operating Pressure for the Suction Side	MPa		2.5
	Sound Pressure Level (H/M/L)	dB (A)		57/-/-
Sound Power Level (H/M/L)	dB (A)		65/-/-	
Dimension(WXHXD)	mm		965X700X396	
Dimension of Carton Box (LXWXH)	mm		1026X455X735	
Dimension of Package(LXWXH)	mm		1029X458X750	
Net Weight	kg		45	
Gross Weight	kg		49.5	
Refrigerant			R32	
Refrigerant Charge	kg		1	
Connection Pipe	Connection Pipe Length	m	5	
	Connection Pipe Gas Additional Charge	g/m	16	
	Outer Diameter Liquid Pipe	mm	Φ6	
	Outer Diameter Gas Pipe	mm	Φ12	
	Max Distance Height	m	10	
	Max Distance Length	m	25	
Note: The connection pipe applies metric diameter.				

The above data is subject to change without notice. Please refer to the nameplate of the unit.

Parameter	Unit	Value	
Model		GWH24QE-K6DND2I	
Product Code		CB461006800	
Power Supply	Rated Voltage	V ~ 220-240	
	Rated Frequency	Hz 50	
	Phases	1	
Power Supply Mode		Outdoor	
Cooling Capacity	W	7000	
Heating Capacity	W	7200	
Cooling Power Input	W	2000	
Heating Power Input	W	1845	
Cooling Current Input	A	9.15	
Heating Current Input	A	8.44	
Rated Input	W	3800	
Rated Current	A	16.42	
Air Flow Volume(SH/H/MH/M/ML/L/SL)	m ³ /h	1250/1100/1000/950/900/850/750	
Dehumidifying Volume	L/h	2.4	
EER	W/W	3.5	
COP	W/W	3.9	
SEER	W/W	7	
HSPF	W/W	/	
Application Area	m ²	27-42	
Indoor Unit	Indoor Unit Model	GWH24QE-K6DND2I/I	
	Indoor Unit Product Code	CB461N06800	
	Fan Type	Cross-flow	
	Fan Diameter Length(DXL)	mm	Φ108X830
	Cooling Speed(SH/H/MH/M/ML/L/SL)	r/min	1250/1100/1000/950/900/850/800/600
	Heating Speed(SH/H/MH/M/ML/L/SL)	r/min	1400/1250/1100/1050/1000/900/850
	Fan Motor Power Output	W	50
	Fan Motor RLA	A	0.35
	Fan Motor Capacitor	μF	/
	Evaporator Form		Aluminum Fin-copper Tube
	Evaporator Pipe Diameter	mm	Φ7
	Evaporator Row-fin Gap	mm	1.5
	Evaporator Coil Length (LXDXW)	mm	850X25.4X342.9
	Swing Motor Model		MP35CJ/MP24HF
	Swing Motor Power Output	W	2.5/1.5
	Fuse Current	A	3.15
	Sound Pressure Level(SH/H/MH/M/ML/L/SL)	dB (A)	49/47/44/42/40/38/36
	Sound Power Level(SH/H/MH/M/ML/L/SL)	dB (A)	65/61/58/56/54/52/50
	Dimension (WXHXD)	mm	1078X325X246
	Dimension of Carton Box (LXWXH)	mm	1145X410X335
Dimension of Package(LXWXH)	mm	1148X413X350	
Net Weight	kg	16.5	
Gross Weight	kg	20	

Outdoor Unit	Outdoor Unit Model		GWH24YE-K6DNA1A/O
	Outdoor Unit Product Code		CB437W01400
	Compressor Manufacturer		ZHUHAI LANDA COMPRESSOR CO.,LTD.
	Compressor Model		QXFS-D23ZX090A
	Compressor Oil		FW68DA
	Compressor Type		Rotary
	Compressor LRA.	A	25
	Compressor RLA	A	11.5
	Compressor Power Input	W	2550
	Compressor Overload Protector		1NT11L-6233/HPC 115/95 /KSD115°C
	Throttling Method		Electron expansion valve
	Set Temperature Range	°C	16~30
	Cooling Operation Ambient Temperature Range	°C	-15~54
	Heating Operation Ambient Temperature Range	°C	-22~24
	Condenser Form		Aluminum Fin-copper Tube
	Condenser Pipe Diameter	mm	Φ7
	Condenser Rows-fin Gap	mm	2-1.4
	Condenser Coil Length (LXDXW)	mm	935X38.1X660
	Fan Motor Speed	rpm	800
	Fan Motor Power Output	W	60
	Fan Motor RLA	A	0.58
	Fan Motor Capacitor	μF	/
	Outdoor Unit Air Flow Volume	m ³ /h	3200
	Fan Type		Axial-flow
	Fan Diameter	mm	Φ520
	Defrosting Method		Automatic Defrosting
	Climate Type		T1
	Isolation		I
	Moisture Protection		IPX4
	Permissible Excessive Operating Pressure for the Discharge Side	MPa	4.3
Permissible Excessive Operating Pressure for the Suction Side	MPa	2.5	
Sound Pressure Level (H/M/L)	dB (A)	60/-/-	
Sound Power Level (H/M/L)	dB (A)	70/-/-	
Dimension(WXHXD)	mm	965X700X396	
Dimension of Carton Box (LXWXH)	mm	1026X455X735	
Dimension of Package(LXWXH)	mm	1029X458X750	
Net Weight	kg	53	
Gross Weight	kg	57.5	
Refrigerant		R32	
Refrigerant Charge	kg	1.7	
Connection Pipe	Connection Pipe Length	m	5
	Connection Pipe Gas Additional Charge	g/m	50
	Outer Diameter Liquid Pipe	mm	Φ6
	Outer Diameter Gas Pipe	mm	Φ16
	Max Distance Height	m	10
	Max Distance Length	m	25
	Note: The connection pipe applies metric diameter.		

The above data is subject to change without notice. Please refer to the nameplate of the unit.

Model		1.GWH12QC-K6DNA1D 2.GWH12QC-K6DNA5D 3.GWH12QC-K6DNE4D 4.GWH12QC-K6DNC6D 5.GWH12QC-K6DNB6D 6.GWH12QC-K6DNA3D 7.GWH12QC-K6DNC8D 8.GWH12QC-K6DNB2D 9.GWH12QC-K6DNB4D 10.GWH12QC-K6DNC6D 11.GWH12QC-K6DNB8D 12.GWH12QC-K6DND2D	
Product Code		1.CB419015501 2.CB425012301 3.CB470002901 4.CB443005701 5.CB435009401 6.CB424008201 7.CB456007101 8.CB432017801 9.CB434012601 10.CB443005703 11.CB438010202 12.CB461005503	
Power Supply	Rated Voltage	V~ 220-240	
	Rated Frequency	Hz 50	
	Phases	1	
Power Supply Mode		Outdoor	
Cooling Capacity	W	3500	
Heating Capacity	W	3670	
Cooling Power Input	W	1085	
Heating Power Input	W	990	
Cooling Current Input	A	5.0	
Heating Current Input	A	4.5	
Rated Input	W	1500	
Rated Current	A	5.0	
Air Flow Volume(SS/H/MH/M/ML/L/SL)	m ³ /h	680/620/560/490/450/420/390	
Dehumidifying Volume	L/h	1.4	
EER	W/W	3.23	
COP	W/W	3.71	
SEER	W/W	7	
SCOP(Average/Warmer/Colder)	W/W	4/5.1/3.3	
Application Area	m ²	16-24	
Indoor Unit	Fan Type	Cross-flow	
	Indoor Unit Model	1.GWH12QC-K6DNA1D/I 2.GWH12QC-K6DNA5D/I 3.GWH12QC-K6DNE4D/I 4.GWH12QC-K6DNC6D/I 5.GWH12QC-K6DNB6D/I 6.GWH12QC-K6DNA3D/I 7.GWH12QC-K6DNC8D/I 8.GWH12QC-K6DNB2D/I 9.GWH12QC-K6DNB4D/I 10.GWH12QC-K6DNC6D/I 11.GWH12QC-K6DNB8D/I 12.GWH12QC-K6DND2D/I	
	Fan Diameter Length(DXL)	mm	Φ98X633.5
	Cooling Speed(SS/H/MH/M/ML/L/SL)	r/min	1350/1200/1100/1000/920/850/800
	Heating Speed(SS/H/MH/M/ML/L/SL)	r/min	1300/1200/1120/1050/980/900/850
	Fan Motor Power Output	W	20
	Fan Motor RLA	A	0.31
	Fan Motor Capacitor	μF	1.5
	Evaporator Form		Aluminum Fin-copper Tube
	Evaporator Pipe Diameter	mm	Φ5
	Evaporator Row-fin Gap	mm	2-1.5
	Evaporator Coil Length (LXDXW)	mm	635X22.8X306.3
	Swing Motor Model		MP24BA/MP24EB
	Swing Motor Power Output	W	1.5/1.5
	Fuse Current	A	3.15
	Sound Pressure Level(SS/H/MH/M/ML/L/SL)	dB (A)	42/38/35/32/30/28/26
	Sound Power Level(SS/H/MH/M/ML/L/SL)	dB (A)	57/50/47/44/42/40/38
	Dimension (WXHDX)	mm	845X289X209
	Dimension of Carton Box (LXWXH)	mm	918X278/364
	Dimension of Package(LXWXH)	mm	931X281X379
Net Weight	kg	10.5	
Gross Weight	kg	12.5	

Outdoor Unit	Outdoor Unit Model		GWH12QC-K6DNA1D/O
	Outdoor Unit Product Code		CB419W15501
	Compressor Manufacturer		ZHUHAI LANDA COMPRESSOR CO.,LTD
	Compressor Model		QXF-A102zE190B
	Compressor Oil		FW68DA
	Compressor Type		Rotary
	Compressor LRA.	A	/
	Compressor RLA	A	4.6
	Compressor Power Input	W	1023
	Compressor Overload Protector		HPC115/95U1/KSD115°C
	Throttling Method		Electron expansion valve
	Set Temperature Range	°C	16~30
	Cooling Operation Ambient Temperature Range	°C	-15~43
	Heating Operation Ambient Temperature Range	°C	-15~24
	Condenser Form		Aluminum Fin-copper Tube
	Condenser Pipe Diameter	mm	Φ7.94
	Condenser Rows-fin Gap	mm	1-1.4
	Condenser Coil Length (LXDXW)	mm	731X19.05X550
	Fan Motor Speed	rpm	900
	Fan Motor Power Output	W	30
	Fan Motor RLA	A	0.36
	Fan Motor Capacitor	μF	/
	Outdoor Unit Air Flow Volume	m ³ /h	2200
	Fan Type		Axial-flow
	Fan Diameter	mm	Φ438
	Defrosting Method		Automatic Defrosting
	Climate Type		T1
	Isolation		I
	Moisture Protection		IPX4
	Permissible Excessive Operating Pressure for the Discharge Side	MPa	4.3
	Permissible Excessive Operating Pressure for the Suction Side	MPa	2.5
	Sound Pressure Level (H/M/L)	dB (A)	52/-/-
Sound Power Level (H/M/L)	dB (A)	62/-/-	
Dimension(WXHXD)	mm	848X596X320	
Dimension of Carton Box (LXWXH)	mm	878X360X630	
Dimension of Package(LXWXH)	mm	881X363X645	
Net Weight	kg	31	
Gross Weight	kg	34	
Refrigerant		R32	
Refrigerant Charge	kg	0.7	
Connection Pipe	Connection Pipe Length	m	5
	Connection Pipe Gas Additional Charge	g/m	16
	Outer Diameter Liquid Pipe	mm	Φ6
	Outer Diameter Gas Pipe	mm	Φ9.52
	Max Distance Height	m	10
	Max Distance Length	m	20
Note: The connection pipe applies metric diameter.			

The above data is subject to change without notice. Please refer to the nameplate of the unit.

Model			GWH12QC-K6DNE4D GWH12QC-K6DNA5D	1.GWH12QC-K6DNA1D 2.GWH12QC-K6DNA5D 3.GWH12QC-K6DNE4D 4.GWH12QC-K6DNB6D 5.GWH12QC-K6DNC2D 6.GWH12QC-K6DNB4D 7.GWH12QC-K6DNB2D 8.GWH12QC-K6DNB8D 9.GWH12QC-K6DNC6D 10.GWH12QC-K6DND2D 11.GWH12QC-K6DND6D	
Product Code			CB470002902 CB425012302	1.CB419015500 2.CB425012300 3.CB470002900 4.CB435009400 5.CB439013100 6.CB434012600 7.CB432017800/CB432017802 8.CB438010200/CB438010201 9.CB443005702 10.CB461005500/CB461005501/CB461005502 11.CB460006700	
Power Supply	Rated Voltage	V~	220-240	220-240	
	Rated Frequency	Hz	50	50	
	Phases		1	1	
Power Supply Mode			Outdoor	Outdoor	
Cooling Capacity		W	3500	3500	
Heating Capacity		W	3670	3670	
Cooling Power Input		W	1085	1085	
Heating Power Input		W	990	990	
Cooling Current Input		A	5.0	5.0	
Heating Current Input		A	4.5	4.5	
Rated Input		W	1500	1500	
Rated Current		A	5.0	5.0	
Air Flow Volume(SS/H/MH/M/ML/L/SL)		m ³ /h	680/620/560/490/450/420/390	680/620/560/490/450/420/390	
Dehumidifying Volume		L/h	1.4	1.4	
EER		W/W	3.23	3.23	
COP		W/W	3.71	3.71	
SEER		W/W	7	7	
SCOP(Average/Warmer/Colder)		W/W	4/5.1/3.3	4/5.1/3.3	
Application Area		m ²	16-24	16-24	
Indoor Unit	Fan Type		Cross-flow	Cross-flow	
	Indoor Unit Model		GWH12QC-K6DNE4D/I GWH12QC-K6DNA5D/I	1.GWH12QC-K6DNA1D/I 2.GWH12QC-K6DNA5D/I 3.GWH12QC-K6DNE4D/I 4.GWH12QC-K6DNB6D/I 5.GWH12QC-K6DNC2D/I 6.GWH12QC-K6DNB4D/I 7.GWH12QC-K6DNB2D/I 8.GWH12QC-K6DNB8D/I 9.GWH12QC-K6DNC6D/I 10.GWH12QC-K6DND2D/I 11.GWH12QC-K6DND6D/I	
	Fan Diameter Length(DXL)		mm	Φ98X633.5	Φ98X633.5
	Cooling Speed(SS/H/MH/M/ML/L/SL)		r/min	1350/1200/1100/1000/920/850/800	1350/1200/1100/1000/920/850/800
	Heating Speed(SS/H/MH/M/ML/L/SL)		r/min	1300/1200/1120/1050/980/900/850	1300/1200/1120/1050/980/900/850
	Fan Motor Power Output		W	20	20
	Fan Motor RLA		A	0.31	0.31
	Fan Motor Capacitor		μF	1.5	1.5
	Evaporator Form			Aluminum Fin-copper Tube	Aluminum Fin-copper Tube
	Evaporator Pipe Diameter		mm	Φ5	Φ5
	Evaporator Row-fin Gap		mm	2-1.5	2-1.5
	Evaporator Coil Length (LXDXW)		mm	635X22.8X306.3	635X22.8X306.3
	Swing Motor Model			MP24BA	MP24BA/MP24EB
	Swing Motor Power Output		W	1.5	1.5/1.5
	Fuse Current		A	3.15	3.15
	Sound Pressure Level(SS/H/MH/M/ML/L/SL)		dB (A)	42/38/35/32/30/28/26	42/38/35/32/30/28/26
	Sound Power Level(SS/H/MH/M/ML/L/SL)		dB (A)	57/50/47/44/42/40/38	57/50/47/44/42/40/38
	Dimension (WXHXD)		mm	845X289X209	845X289X209
	Dimension of Carton Box (LXWXH)		mm	918X278/364	918X278/364
	Dimension of Package(LXWXH)		mm	931X281X379	931X281X379
Net Weight		kg	10.5	10.5	
Gross Weight		kg	12.5	12.5	

Outdoor Unit	Outdoor Unit Model		GWH12QC-K6DNA1D/O
	Outdoor Unit Product Code		CB419W15500
	Compressor Manufacturer		ZHUHAI LANDA COMPRESSOR CO.,LTD
	Compressor Model		QXF-A102zE190B
	Compressor Oil		FW68DA
	Compressor Type		Rotary
	Compressor LRA.	A	/
	Compressor RLA	A	4.6
	Compressor Power Input	W	1023
	Compressor Overload Protector		HPC115/95U1/KSD115°C
	Throttling Method		Electron expansion valve
	Set Temperature Range	°C	16~30
	Cooling Operation Ambient Temperature Range	°C	-15~43
	Heating Operation Ambient Temperature Range	°C	-22~24
	Condenser Form		Aluminum Fin-copper Tube
	Condenser Pipe Diameter	mm	Φ7.94
	Condenser Rows-fin Gap	mm	1-1.4
	Condenser Coil Length (LXDXW)	mm	731X19.05X550
	Fan Motor Speed	rpm	900
	Fan Motor Power Output	W	30
	Fan Motor RLA	A	0.36
	Fan Motor Capacitor	μF	/
	Outdoor Unit Air Flow Volume	m ³ /h	2200
	Fan Type		Axial-flow
	Fan Diameter	mm	Φ438
	Defrosting Method		Automatic Defrosting
	Climate Type		T1
	Isolation		I
	Moisture Protection		IPX4
	Permissible Excessive Operating Pressure for the Discharge Side	MPa	4.3
	Permissible Excessive Operating Pressure for the Suction Side	MPa	2.5
	Sound Pressure Level (H/M/L)	dB (A)	52/-/-
Sound Power Level (H/M/L)	dB (A)	62/-/-	
Dimension(WXHXD)	mm	848X596X320	
Dimension of Carton Box (LXWXH)	mm	878X360X630	
Dimension of Package(LXWXH)	mm	881X363X645	
Net Weight	kg	31	
Gross Weight	kg	34	
Refrigerant		R32	
Refrigerant Charge	kg	0.7	
Connection Pipe	Connection Pipe Length	m	5
	Connection Pipe Gas Additional Charge	g/m	16
	Outer Diameter Liquid Pipe	mm	Φ6
	Outer Diameter Gas Pipe	mm	Φ9.52
	Max Distance Height	m	10
	Max Distance Length	m	20
Note: The connection pipe applies metric diameter.			

The above data is subject to change without notice. Please refer to the nameplate of the unit.

Model			1.GWH18QD-K6DNA1D 2.GWH18QD-K6DNA5D 3.GWH18QD-K6DNB6D 4.GWH18QD-K6DNB2D 5.GWH18QD-K6DNC2E 6.GWH18QD-K6DNE4D 7.GWH18QD-K6DNB4D 8.GWH18QD-K6DNB8D 9.GWH18QD-K6DNC6D 10.GWH18QD-K6DND2D 11.GWH18QD-K6DND6D	GWH18QD-K6DNE4D GWH18QD-K6DNA5D	
Product Code			1.CB419015600 2.CB425012400 3.CB435009500 4.CB432017900 5.CB439013200 6.CB470003000 7.CB434012500 8.CB438010300 9.CB443005802 10.CB461005702/CB461005701/ CB461005700 11.CB460006600	CB470003001 CB425012402	
Power Supply	Rated Voltage	V~	220-240	220-240	
	Rated Frequency	Hz	50	50	
	Phases		1	1	
Power Supply Mode			Outdoor	Outdoor	
Cooling Capacity		W	5200	5200	
Heating Capacity		W	5300	5300	
Cooling Power Input		W	1528	1528	
Heating Power Input		W	1410	1410	
Cooling Current Input		A	6.78	6.78	
Heating Current Input		A	6.26	6.26	
Rated Input		W	2600	2600	
Rated Current		A	6.78	6.78	
Air Flow Volume(SH/H/MH/M/ML/L/SL)		m ³ /h	800/720/650/610/570/520/470	800/720/650/610/570/520/470	
Dehumidifying Volume		L/h	1.8	1.8	
EER		W/W	3.40	3.40	
COP		W/W	3.76	3.76	
SEER		W/W	7	7	
SCOP(Average/Warmer/Colder)		W/W	/	/	
Application Area		m ²	23-34	23-34	
Indoor Unit	Indoor Unit Model		1.GWH18QD-K6DNA1D/I 2.GWH18QD-K6DNA5D/I 3.GWH18QD-K6DNB6D/I 4.GWH18QD-K6DNB2D/I 5.GWH18QD-K6DNC2E/I 6.GWH18QD-K6DNE4D/I 7.GWH18QD-K6DNB4D/I 8.GWH18QD-K6DNB8D/I 9.GWH18QD-K6DNC6D/I 10.GWH18QD-K6DND2D/I 11.GWH18QD-K6DND6D/I	GWH18QD-K6DNE4D/I GWH18QD-K6DNA5D/I	
	Fan Type		Cross-flow	Cross-flow	
	Fan Diameter Length(DXL)		mm	Φ106X706	Φ106X706
	Cooling Speed(SS/H/MH/M/ML/L/SL)		r/min	1230/1150/1080/980/900/850/800	1230/1150/1080/980/900/850/800
	Heating Speed(SS/H/MH/M/ML/L/SL)		r/min	1350/1250/1150/1050/980/900/850	1350/1250/1150/1050/980/900/850
	Fan Motor Power Output		W	35	35
	Fan Motor RLA		A	0.35	0.35
	Fan Motor Capacitor		μF	2.5	2.5
	Evaporator Form			Aluminum Fin-copper Tube	Aluminum Fin-copper Tube
	Evaporator Pipe Diameter		mm	Φ7	Φ7
	Evaporator Row-fin Gap		mm	2-1.4	2-1.4
	Evaporator Coil Length (LXDXW)		mm	715X25.4X304.8	715X25.4X304.8
	Swing Motor Model			MP35CJ/MP24HF	MP35CJ
	Swing Motor Power Output		W	2.5/1.5	2.5/1.5
	Fuse Current		A	3.15	3.15
	Sound Pressure Level(SH/H/MH/M/ML/L/SL)		dB (A)	45/43/41/38/35/34/31	45/43/41/38/35/34/31
	Sound Power Level(SH/H/MH/M/ML/L/SL)		dB (A)	55/53/51/48/45/44/41	55/53/51/48/45/44/41
	Dimension (WXHXD)		mm	970X300X224	970X300X224
	Dimension of Carton Box (LXWXH)		mm	1038X380X305	1038X380X305
	Dimension of Package(LXWXH)		mm	1041X383X320	1041X383X320
Net Weight		kg	13.5	13.5	
Gross Weight		kg	16.5	16.5	

Outdoor Unit	Outdoor Unit Model		GWH18QD-K6DNA1D/O(LCLH)	
	Outdoor Unit Product Code		CB419W15600	
	Compressor Manufacturer		ZHUHAI LANDA COMPRESSOR CO.,LTD	
	Compressor Model		QXF-B141ZF030F	
	Compressor Oil		FW68DA or equivalent	
	Compressor Type		Rotary	
	Compressor LRA.	A		25
	Compressor RLA	A		6.5
	Compressor Power Input	W		1410
	Compressor Overload Protector			HPC115/95U1 KSD115℃
	Throttling Method			Electron expansion valve
	Set Temperature Range	℃		16~30
	Cooling Operation Ambient Temperature Range	℃		-15~43
	Heating Operation Ambient Temperature Range	℃		-22~24
	Condenser Form			Aluminum Fin-copper Tube
	Condenser Pipe Diameter	mm		Φ7
	Condenser Rows-fin Gap	mm		2-1.4
	Condenser Coil Length (LXDXW)	mm		851X38.1X660
	Fan Motor Speed	rpm		800
	Fan Motor Power Output	W		60
	Fan Motor RLA	A		0.4
	Fan Motor Capacitor	μF		/
	Outdoor Unit Air Flow Volume	m ³ /h		3200
	Fan Type			Axial-flow
	Fan Diameter	mm		Φ520
	Defrosting Method			Automatic Defrosting
	Climate Type			T1
	Isolation			I
	Moisture Protection			IPX4
	Permissible Excessive Operating Pressure for the Discharge Side	MPa		4.3
	Permissible Excessive Operating Pressure for the Suction Side	MPa		2.5
	Sound Pressure Level (H/M/L)	dB (A)		57/-/-
Sound Power Level (H/M/L)	dB (A)		64/-/-	
Dimension(WXHXD)	mm		965X700X396	
Dimension of Carton Box (LXWXH)	mm		1026X455X735	
Dimension of Package(LXWXH)	mm		1029X458X750	
Net Weight	kg		45	
Gross Weight	kg		49.5	
Refrigerant			R32	
Refrigerant Charge	kg		1	
Connection Pipe	Connection Pipe Length	m	5	
	Connection Pipe Gas Additional Charge	g/m	16	
	Outer Diameter Liquid Pipe	mm	Φ6	
	Outer Diameter Gas Pipe	mm	Φ12	
	Max Distance Height	m	10	
	Max Distance Length	m	25	
	Note: The connection pipe applies metric diameter.			

The above data is subject to change without notice. Please refer to the nameplate of the unit.

Model			1.GWH18QD-K6DNA1D 2.GWH18QD-K6DNA5D 3.GWH18QD-K6DNC6D 4.GWH18QD-K6DNB6D 5.GWH18QD-K6DNC4D 6.GWH18QD-K6DNA3D 7.GWH18QD-K6DNB2D 8.GWH18QD-K6DNB2D 9.GWH18QD-K6DNC6D 10.GWH18QD-K6DNB4D 11.GWH18QD-K6DNB8D	
Product Code			1.CB419015601 2.CB425012401 3.CB443005801 4.CB435009501 5.CB444012301 6.CB424008101 7.CB432017901/CB432017902 8.CB432017902 9.CB443005803 10.CB434012501 11.CB438010301	
Power Supply	Rated Voltage	V~	220-240	
	Rated Frequency	Hz	50	
	Phases		1	
Power Supply Mode			Outdoor	
Cooling Capacity		W	5200	
Heating Capacity		W	5300	
Cooling Power Input		W	1528	
Heating Power Input		W	1410	
Cooling Current Input		A	6.78	
Heating Current Input		A	6.26	
Rated Input		W	2600	
Rated Current		A	6.78	
Air Flow Volume(SH/H/MH/M/ML/L/SL)		m ³ /h	800/720/650/610/570/520/470	
Dehumidifying Volume		L/h	1.8	
EER		W/W	3.4	
COP		W/W	3.76	
SEER		W/W	7	
SCOP(Average/Warmer/Colder)		W/W	/	
Application Area		m ²	23-34	
Indoor Unit	Indoor Unit Model		1.GWH18QD-K6DNA1D/I 2.GWH18QD-K6DNA5D/I 3.GWH18QD-K6DNC6D/I 4.GWH18QD-K6DNB6D/I 5.GWH18QD-K6DNC4D/I 6.GWH18QD-K6DNA3D/I 7.GWH18QD-K6DNB2D/I 8.GWH18QD-K6DNB2D/I 9.GWH18QD-K6DNC6D/I 10.GWH18QD-K6DNB4D/I 11.GWH18QD-K6DNB8D/I	
	Fan Type		Cross-flow	
	Fan Diameter Length(DXL)		mm	Φ106X706
	Cooling Speed(SH/H/M/L/SL)		r/min	1230/1150/1080/980/900/850/800
	Heating Speed(SH/H/M/L/SL)		r/min	1350/1250/1150/1050/980/900/850
	Fan Motor Power Output		W	35
	Fan Motor RLA		A	0.35
	Fan Motor Capacitor		μF	2.5
	Evaporator Form			Aluminum Fin-copper Tube
	Evaporator Pipe Diameter		mm	Φ7
	Evaporator Row-fin Gap		mm	2-1.4
	Evaporator Coil Length (LXDXW)		mm	715X25.4X304.8
	Swing Motor Model			MP35CJ/MP24HF
	Swing Motor Power Output		W	2.5/1.5
	Fuse Current		A	3.15
	Sound Pressure Level(SH/H/MH/M/ML/L/SL)		dB (A)	45/43/41/38/35/34/31
	Sound Power Level(SH/H/MH/M/ML/L/SL)		dB (A)	55/53/51/48/45/44/41
	Dimension (WXHXD)		mm	970X300X224
	Dimension of Carton Box (LXWXH)		mm	1038X380X305
	Dimension of Package(LXWXH)		mm	1041X383X320
Net Weight		kg	13.5	
Gross Weight		kg	16.5	

Outdoor Unit	Outdoor Unit Model		GWH18QD-K6DNA1D/O(LC)	
	Outdoor Unit Product Code		CB419W15601	
	Compressor Manufacturer		ZHUHAI LANDA COMPRESSOR CO.,LTD	
	Compressor Model		QXF-B141ZF030F	
	Compressor Oil		FW68DA or equivalent	
	Compressor Type		Rotary	
	Compressor LRA.	A		25
	Compressor RLA	A		6.5
	Compressor Power Input	W		1410
	Compressor Overload Protector			HPC115/95U1 KSD115℃
	Throttling Method			Electron expansion valve
	Set Temperature Range	℃		16~30
	Cooling Operation Ambient Temperature Range	℃		-15~43
	Heating Operation Ambient Temperature Range	℃		-15~24
	Condenser Form			Aluminum Fin-copper Tube
	Condenser Pipe Diameter	mm		Φ7
	Condenser Rows-fin Gap	mm		2-1.4
	Condenser Coil Length (LXDXW)	mm		851X38.1X660
	Fan Motor Speed	rpm		800
	Fan Motor Power Output	W		60
	Fan Motor RLA	A		0.4
	Fan Motor Capacitor	μF		/
	Outdoor Unit Air Flow Volume	m ³ /h		3200
	Fan Type			Axial-flow
	Fan Diameter	mm		Φ520
	Defrosting Method			Automatic Defrosting
	Climate Type			T1
	Isolation			I
	Moisture Protection			IPX4
	Permissible Excessive Operating Pressure for the Discharge Side	MPa		4.3
	Permissible Excessive Operating Pressure for the Suction Side	MPa		2.5
	Sound Pressure Level (H/M/L)	dB (A)		57/-/-
Sound Power Level (H/M/L)	dB (A)		64/-/-	
Dimension(WXHXD)	mm		965X700X396	
Dimension of Carton Box (LXWXH)	mm		1026X455X735	
Dimension of Package(LXWXH)	mm		1029X458X750	
Net Weight	kg		45	
Gross Weight	kg		49.5	
Refrigerant			R32	
Refrigerant Charge	kg		1	
Connection Pipe	Connection Pipe Length	m	5	
	Connection Pipe Gas Additional Charge	g/m	16	
	Outer Diameter Liquid Pipe	mm	Φ6	
	Outer Diameter Gas Pipe	mm	Φ12	
	Max Distance Height	m	10	
	Max Distance Length	m	25	
	Note: The connection pipe applies metric diameter.			

The above data is subject to change without notice. Please refer to the nameplate of the unit.

Model			1.GWH24QE-K6DNA1E 2.GWH24QE-K6DNC2E 3.GWH24QE-K6DNB6E 4.GWH24QE-K6DNA5E 5.GWH24QE-K6DNB4E 6.GWH24QE-K6DNB2E 7.GWH24QE-K6DNC4E 8.GWH24QE-K6DNE4E 9.GWH24QE-K6DNB8E 10.GWH24QE-K6DNC6E 11.GWH24QE-K6DND2E 12.GWH24QE-K6DND6E	GWH24QE-K6DNE4E GWH24QE-K6DNA5E GWH24QE-K6DNC2E	
Product Code			1.CB419015700 2.CB439013000 3.CB435009300 4.CB425012200 5.CB434012400 6.CB432017700 7.CB444009800 8.CB470002800 9.CB438010400 10.CB443005903 11.CB461005600/CB461005601/CB461005602 12.CB460006500	CB470002801 CB425012203 CB439013001	
Power Supply	Rated Voltage	V~	220-240	220-240	
	Rated Frequency	Hz	50	50	
	Phases		1	1	
Power Supply Mode			Outdoor	Outdoor	
Cooling Capacity		W	7000	7000	
Heating Capacity		W	7400	7400	
Cooling Power Input		W	1900	1900	
Heating Power Input		W	1897	1897	
Cooling Current Input		A	8.73	8.73	
Heating Current Input		A	8.84	8.84	
Rated Input		W	3750	3750	
Rated Current		A	8.73	8.73	
Air Flow Volume(SH/H/MH/M/ML/L/SL)		m ³ /h	1250/1100/1000/950/900/850/750	1250/1100/1000/950/900/850/750	
Dehumidifying Volume		L/h	2.4	2.4	
EER		W/W	3.68	3.68	
COP		W/W	3.90	3.90	
SEER		W/W	6.5	6.5	
SCOP(Average/Warmer/Colder)		W/W	/	/	
Application Area		m ²	27-42	27-42	
Indoor Unit	Indoor Unit Model		1.GWH24QE-K6DNA1E/I 2.GWH24QE-K6DNC2E/I 3.GWH24QE-K6DNB6E/I 4.GWH24QE-K6DNA5E/I 5.GWH24QE-K6DNB4E/I 6.GWH24QE-K6DNB2E/I 7.GWH24QE-K6DNC4E/I 8.GWH24QE-K6DNE4E/I 9.GWH24QE-K6DNB8E/I 10.GWH24QE-K6DNC6E/I 11.GWH24QE-K6DND2E/I 12.GWH24QE-K6DND6E/I	GWH24QE-K6DNE4E/I GWH24QE-K6DNA5E/I GWH24QE-K6DNC2E/I	
	Fan Type		Cross-flow	Cross-flow	
	Fan Diameter Length(DXL)		mm	Φ108X830	Φ108X830
	Cooling Speed(SH/H/M/ML/SL)		r/min	1250/1150/1050/950/900/850/800	1250/1150/1050/950/900/850/800
	Heating Speed(SH/H/M/ML/SL)		r/min	1250/1150/1050/1000/950/900/850	1250/1150/1050/1000/950/900/850
	Fan Motor Power Output		W	35	35
	Fan Motor RLA		A	0.35	0.35
	Fan Motor Capacitor		μF	3	3
	Evaporator Form			Aluminum Fin-copper Tube	Aluminum Fin-copper Tube
	Evaporator Pipe Diameter		mm	Φ7	Φ7
	Evaporator Row-fin Gap		mm	2-1.4	2-1.4
	Evaporator Coil Length (LXDXW)		mm	850X25.4X342.9	850X25.4X342.9
	Swing Motor Model			MP35CJ/MP24HF	MP35CJ
	Swing Motor Power Output		W	2.5/1.5	2.5
	Fuse Current		A	3.15	3.15
	Sound Pressure Level(SH/H/MH/M/ML/L/SL)		dB (A)	48/45/42/39/37/36/33	48/45/42/39/37/36/33
	Sound Power Level(SH/H/MH/M/ML/L/SL)		dB (A)	58/55/52/49/47/46/43	58/55/52/49/47/46/43
	Dimension (WXHXD)		mm	1078X325X246	1078X325X246
	Dimension of Carton Box (LXWXH)		mm	1145X410X335	1145X410X335
	Dimension of Package(LXWXH)		mm	1148X413X350	1148X413X350
Net Weight		kg	16.5	16.5	
Gross Weight		kg	20	20	

Outdoor Unit	Outdoor Unit Model		GWH24QE-K6DNA1E/O	
	Outdoor Unit Product Code		CB419W15700	
	Compressor Manufacturer		ZHUHAI LANDA COMPRESSOR CO., LTD	
	Compressor Model		QXFS-D25zX090H	
	Compressor Oil		FW68DA	
	Compressor Type		Rotary	
	Compressor LRA	A		24
	Compressor RLA	A		11.7
	Compressor Power Input	W		2420
	Compressor Overload Protector			HPC115/95U1/KSD115°C
	Throttling Method			Electron expansion valve
	Set Temperature Range	°C		16~30
	Cooling Operation Ambient Temperature Range	°C		-15~43
	Heating Operation Ambient Temperature Range	°C		-22~24
	Condenser Form			Aluminum Fin-copper Tube
	Condenser Pipe Diameter	mm		Φ7
	Condenser Rows-fin Gap	mm		2-1.4
	Condenser Coil Length (LXDXW)	mm		935X38.1X660
	Fan Motor Speed	rpm		800
	Fan Motor Power Output	W		60
	Fan Motor RLA	A		0.58
	Fan Motor Capacitor	μF		/
	Outdoor Unit Air Flow Volume	m ³ /h		3200
	Fan Type			Axial-flow
	Fan Diameter	mm		Φ520
	Defrosting Method			Automatic Defrosting
	Climate Type			T1
	Isolation			I
	Moisture Protection			IPX4
	Permissible Excessive Operating Pressure for the Discharge Side	MPa		4.3
	Permissible Excessive Operating Pressure for the Suction Side	MPa		2.5
	Sound Pressure Level (H/M/L)	dB (A)		57/-/-
	Sound Power Level (H/M/L)	dB (A)		67/-/-
Dimension(WXHxD)	mm		965X700X396	
Dimension of Carton Box (LXWXH)	mm		1026X455X735	
Dimension of Package(LXWXH)	mm		1029X458X750	
Net Weight	kg		53.5	
Gross Weight	kg		58	
Refrigerant			R32	
Refrigerant Charge	kg		1.7	
Connection Pipe	Connection Pipe Length	m	5	
	Connection Pipe Gas Additional Charge	g/m	50	
	Outer Diameter Liquid Pipe	mm	Φ6	
	Outer Diameter Gas Pipe	mm	Φ16	
	Max Distance Height	m	10	
	Max Distance Length	m	25	
Note: The connection pipe applies metric diameter.				

The above data is subject to change without notice. Please refer to the nameplate of the unit.

Model			1.GWH24QE-K6DNB4E 2.GWH24QE-K6DNA5E 3.GWH24QE-K6DNC6E 4.GWH24QE-K6DNB6E 5.GWH24QE-K6DNB2E 6.GWH24QE-K6DNB8E 7.GWH24QE-K6DNB4E	1.GWH24QE-K6DNA1E 2.GWH24QE-K6DNA5E 3.GWH24QE-K6DNC6E 4.GWH24QE-K6DNC4E	
Product Code			1.CB434012402 2.CB425012202 3.CB443005902/CB443005904 4.CB435009301 5.CB432017701/CB432017702 6.CB438010401 7.CB434012403	1.CB419015701 2.CB425012201 3.CB443005901 4.CB444009801	
Power Supply	Rated Voltage	V~	220-240	220-240	
	Rated Frequency	Hz	50	50	
	Phases		1	1	
Power Supply Mode			Outdoor	Outdoor	
Cooling Capacity		W	7000	7000	
Heating Capacity		W	7400	7400	
Cooling Power Input		W	1900	1900	
Heating Power Input		W	1897	1897	
Cooling Current Input		A	8.73	8.73	
Heating Current Input		A	8.84	8.84	
Rated Input		W	3750	3750	
Rated Current		A	8.73	8.73	
Air Flow Volume(SH/H/MH/M/ML/L/SL)		m ³ /h	1250/1100/1000/950/900/850/750	1250/1100/1000/950/900/850/750	
Dehumidifying Volume		L/h	2.4	2.4	
EER		W/W	3.68	3.68	
COP		W/W	3.90	3.90	
SEER		W/W	6.5	6.5	
SCOP(Average/Warmer/Colder)		W/W	/	/	
Application Area		m ²	27-42	27-42	
Indoor Unit	Indoor Unit Model		1.GWH24QE-K6DNB4E/I 2.GWH24QE-K6DNA5E/I 3.GWH24QE-K6DNC6E/I 4.GWH24QE-K6DNB6E/I 5.GWH24QE-K6DNB2E/I 6.GWH24QE-K6DNB8E/I 7.GWH24QE-K6DNB4E/I	1.GWH24QE-K6DNA1E/I 2.GWH24QE-K6DNA5E/I 3.GWH24QE-K6DNC6E/I 4.GWH24QE-K6DNC4E/I	
	Fan Type		Cross-flow	Cross-flow	
	Fan Diameter Length(DXL)		mm	Φ108X830	Φ108X830
	Cooling Speed(SH/H/M/L/SL)		r/min	1250/1150/1050/950/900/850/800	1250/1150/1050/950/900/850/800
	Heating Speed(SH/H/M/L/SL)		r/min	1250/1150/1050/1000/950/900/850	1250/1150/1050/1000/950/900/850
	Fan Motor Power Output		W	35	35
	Fan Motor RLA		A	0.35	0.35
	Fan Motor Capacitor		μF	3	3
	Evaporator Form			Aluminum Fin-copper Tube	Aluminum Fin-copper Tube
	Evaporator Pipe Diameter		mm	Φ7	Φ7
	Evaporator Row-fin Gap		mm	2-1.4	2-1.4
	Evaporator Coil Length (LXDXW)		mm	850X25.4X342.9	850X25.4X342.9
	Swing Motor Model			MP35CJ/MP24HF	MP35CJ
	Swing Motor Power Output		W	2.5/1.5	2.5/1.5
	Fuse Current		A	3.15	3.15
	Sound Pressure Level(SH/H/MH/M/ML/L/SL)		dB (A)	48/45/42/39/37/36/33	48/45/42/39/37/36/33
	Sound Power Level(SH/H/MH/M/ML/L/SL)		dB (A)	58/55/52/49/47/46/43	58/55/52/49/47/46/43
	Dimension (WXHXD)		mm	1078X325X246	1078X325X246
	Dimension of Carton Box (LXWXH)		mm	1145X410X335	1145X410X335
	Dimension of Package(LXWXH)		mm	1148X413X350	1148X413X350
Net Weight		kg	16.5	16.5	
Gross Weight		kg	20	20	

Outdoor Unit	Outdoor Unit Model		GWH24QE-K6DNA1E/O	
	Outdoor Unit Product Code		CB419W15701	
	Compressor Manufacturer		ZHUHAI LANDA COMPRESSOR CO., LTD	
	Compressor Model		QXFS-D25zX090H	
	Compressor Oil		FW68DA	
	Compressor Type		Rotary	
	Compressor LRA.	A		24
	Compressor RLA	A		11.7
	Compressor Power Input	W		2420
	Compressor Overload Protector			HPC115/95U1/KSD115°C
	Throttling Method			Electron expansion valve
	Set Temperature Range	°C		16~30
	Cooling Operation Ambient Temperature Range	°C		-15~43
	Heating Operation Ambient Temperature Range	°C		-15~24
	Condenser Form			Aluminum Fin-copper Tube
	Condenser Pipe Diameter	mm		Φ7
	Condenser Rows-fin Gap	mm		2-1.4
	Condenser Coil Length (LXDXW)	mm		935X38.1X660
	Fan Motor Speed	rpm		800
	Fan Motor Power Output	W		60
	Fan Motor RLA	A		0.58
	Fan Motor Capacitor	μF		/
	Outdoor Unit Air Flow Volume	m ³ /h		3200
	Fan Type			Axial-flow
	Fan Diameter	mm		Φ520
	Defrosting Method			Automatic Defrosting
	Climate Type			T1
	Isolation			I
	Moisture Protection			IPX4
	Permissible Excessive Operating Pressure for the Discharge Side	MPa		4.3
	Permissible Excessive Operating Pressure for the Suction Side	MPa		2.5
	Sound Pressure Level (H/M/L)	dB (A)		57/-/-
	Sound Power Level (H/M/L)	dB (A)		67/-/-
Dimension(WXHxD)	mm		965X700X396	
Dimension of Carton Box (LXWXH)	mm		1026X455X735	
Dimension of Package(LXWXH)	mm		1029X458X750	
Net Weight	kg		53.5	
Gross Weight	kg		58	
Refrigerant			R32	
Refrigerant Charge	kg		1.7	
Connection Pipe	Connection Pipe Length	m	5	
	Connection Pipe Gas Additional Charge	g/m	50	
	Outer Diameter Liquid Pipe	mm	Φ6	
	Outer Diameter Gas Pipe	mm	Φ16	
	Max Distance Height	m	10	
	Max Distance Length	m	25	
Note: The connection pipe applies metric diameter.				

The above data is subject to change without notice. Please refer to the nameplate of the unit.

Parameter		Unit	Value		
Model			GWH24QE-K6DNA5X	GWH18QD-K6DNA5X	
Product Code			CB425015400	CB425015300	
Power Supply	Rated Voltage	V~	220-240	220-240	
	Rated Frequency	Hz	50	50	
	Phases		1	1	
Power Supply Mode			Outdoor	Outdoor	
Cooling Capacity		W	6600	5200	
Heating Capacity		W	7200	5300	
Cooling Power Input		W	1890	1528	
Heating Power Input		W	1890	1430	
Cooling Current Input		A	8.73	6.8	
Heating Current Input		A	8.84	6.3	
Rated Input		W	3750	2600	
Rated Current		A	15	10.9	
Air Flow Volume(SH/H/MH/M/ML/L/SL)		m ³ /h	1250/1100/1000/950/900/850/750	800/720/650/610/570/520/470	
Dehumidifying Volume		L/h	2.4	1.8	
EER		W/W	3.49	3.40	
COP		W/W	3.81	3.70	
SEER		W/W	6.5	7	
SCOP(Average/Warmer/Colder)		W/W	4.0/5.1/3.3	4.0/5.1/3.4	
Application Area		m ²	27-42	23-34	
Indoor Unit	Indoor Unit Model		GWH24QE-K6DNA5X/I	GWH18QD-K6DNA5X/I	
	Indoor Unit Product Code		CB425N15400	CB425N15300	
	Fan Type		Cross-flow	Cross-flow	
	Fan Diameter Length(DXL)		mm	Φ108X830	Φ106X706
	Cooling Speed(SH/H/ML/SL)		r/min	1250/1150/1050/950/900/850/800	1230/1150/1080/980/900/850/800
	Heating Speed(SH/H/ML/SL)		r/min	1250/1150/1050/1000/950/900/850	1350/1250/1150/1050/980/900/850
	Fan Motor Power Output		W	35	35
	Fan Motor RLA		A	0.35	0.35
	Fan Motor Capacitor		μF	3	2.5
	Evaporator Form			Aluminum Fin-copper Tube	Aluminum Fin-copper Tube
	Evaporator Pipe Diameter		mm	Φ7	Φ7
	Evaporator Row-fin Gap		mm	2-1.4	2-1.4
	Evaporator Coil Length (LXD _{XW})		mm	850X25.4X342.9	715X25.4X304.8
	Swing Motor Model			MP35CP	MP35CP/MP24HF
	Swing Motor Power Output		W	2.5	2.5/1.5
	Fuse Current		A	3.15	3.15
	Sound Pressure Level(SH/H/MH/M/ML/L/SL)		dB (A)	48/45/42/39/37/36/33	45/43/41/38/35/34/31
	Sound Power Level(SH/H/MH/M/ML/L/SL)		dB (A)	65/60/57/54/52/51/48	58/56/54/51/48/47/44
	Dimension (WXHXD)		mm	1078X325X246	970X300X224
	Dimension of Carton Box (LXWXH)		mm	1145X410X335	1038X380X305
	Dimension of Package(LXWXH)		mm	1148X413X350	1041X383X320
Net Weight		kg	16.5	13.5	
Gross Weight		kg	20	16.5	

Outdoor Unit	Outdoor Unit Model		GWH24QE-K6DNA5X/O	GWH18QD-K6DNA5X/O
	Outdoor Unit Product Code		CB425W15400	CB425W15300
	Compressor Manufacturer		ZHUHAI LANDA COMPRESSOR CO., LTD	ZHUHAI LANDA COMPRESSOR CO.,LTD
	Compressor Model		QXFS-D25zX090H	QXF-B141ZF030F
	Compressor Oil		FW68DA	FW68DA or equivalent
	Compressor Type		Rotary	Rotary
	Compressor LRA.	A	24	25
	Compressor RLA	A	11.7	6.5
	Compressor Power Input	W	2420	1410
	Compressor Overload Protector		HPC115/95U1/KSD115°C	HPC115/95U1 KSD115°C
	Throttling Method		Electron expansion valve	Electron expansion valve
	Set Temperature Range	°C	16~30	16~30
	Cooling Operation Ambient Temperature Range	°C	-15~43	-15~43
	Heating Operation Ambient Temperature Range	°C	-22~24	-15~24
	Condenser Form		Aluminum Fin-copper Tube	Aluminum Fin-copper Tube
	Condenser Pipe Diameter	mm	Φ7	Φ7
	Condenser Rows-fin Gap	mm	2-1.4	2-1.4
	Condenser Coil Length (LXDXW)	mm	935X38.1X660	851X38.1X660
	Fan Motor Speed	rpm	800	800
	Fan Motor Power Output	W	60	60
	Fan Motor RLA	A	0.58	0.5
	Fan Motor Capacitor	μF	/	/
	Outdoor Unit Air Flow Volume	m ³ /h	3200	3200
	Fan Type		Axial-flow	Axial-flow
	Fan Diameter	mm	Φ520	Φ520
	Defrosting Method		Automatic Defrosting	Automatic Defrosting
	Climate Type		T1	T1
	Isolation		I	I
	Moisture Protection		IPX4	IPX4
	Permissible Excessive Operating Pressure for the Discharge Side	MPa	4.3	4.3
	Permissible Excessive Operating Pressure for the Suction Side	MPa	2.5	2.5
	Sound Pressure Level (H/M/L)	dB (A)	57/-/-	57/-/-
	Sound Power Level (H/M/L)	dB (A)	70/-/-	65/-/-
Dimension(WXHXD)	mm	965X700X396	965X700X396	
Dimension of Carton Box (LXWXH)	mm	1026X455X735	1026X455X735	
Dimension of Package(LXWXH)	mm	1029X458X750	1029X458X750	
Net Weight	kg	53.5	45	
Gross Weight	kg	58	49.5	
Refrigerant		R32	R32	
Refrigerant Charge	kg	1.7	1	
Connection Pipe	Connection Pipe Length	m	5	5
	Connection Pipe Gas Additional Charge	g/m	40	16
	Outer Diameter Liquid Pipe	mm	Φ6	Φ6
	Outer Diameter Gas Pipe	mm	Φ16	Φ12
	Max Distance Height	m	10	10
	Max Distance Length	m	25	25
Note: The connection pipe applies metric diameter.				

The above data is subject to change without notice. Please refer to the nameplate of the unit.

Parameter	Unit	Value	
Model		GWH12QC-K6DNA5X	
Product Code		CB425015500	
Power Supply	Rated Voltage	V~ 220-240	
	Rated Frequency	Hz 50	
	Phases	1	
Power Supply Mode		Outdoor	
Cooling Capacity	W	3500	
Heating Capacity	W	3670	
Cooling Power Input	W	1085	
Heating Power Input	W	990	
Cooling Current Input	A	5.0	
Heating Current Input	A	4.5	
Rated Input	W	1500	
Rated Current	A	6.6	
Air Flow Volume(SS/H/MH/M/ML/L/SL)	m ³ /h	680/620/560/490/450/420/390	
Dehumidifying Volume	L/h	1.4	
EER	W/W	3.23	
COP	W/W	3.71	
SEER	W/W	6.8	
SCOP(Average/Warmer/Colder)	W/W	4/-/-	
Application Area	m ²	16-24	
Indoor Unit	Indoor Unit Model		GWH12QC-K6DNA5X/I
	Indoor Unit Product Code		CB425N15500
	Fan Type		Cross-flow
	Fan Diameter Length(DXL)	mm	Φ98X633.5
	Cooling Speed(SS/H/MH/M/ML/L/SL)	r/min	1350/1200/1100/1000/920/850/800
	Heating Speed(SS/H/MH/M/ML/L/SL)	r/min	1300/1200/1120/1050/980/900/850
	Fan Motor Power Output	W	20
	Fan Motor RLA	A	0.31
	Fan Motor Capacitor	μF	1.5
	Evaporator Form		Aluminum Fin-copper Tube
	Evaporator Pipe Diameter	mm	Φ5
	Evaporator Row-fin Gap	mm	2-1.4
	Evaporator Coil Length(LXDXW)	mm	635X22.8X306.3
	Swing Motor Model		MP24BA/MP24EB
	Swing Motor Power Output	W	1.5/1.5
	Fuse Current	A	3.15
	Sound Pressure Level(SS/H/MH/M/ML/L/SL)	dB (A)	42/38/35/32/30/28/26
	Sound Power Level(SS/H/MH/M/ML/L/SL)	dB (A)	59/52/47/44/42/40/38
	Dimension (WXHxD)	mm	845X289X209
	Dimension of Carton Box (LXWXH)	mm	918X278/364
Dimension of Package(LXWXH)	mm	931X281X379	
Net Weight	kg	10.5	
Gross Weight	kg	12.5	

Outdoor Unit	Outdoor Unit Model		GWH12QC-K6DNA5X/O	
	Outdoor Unit Product Code		CB425W15500	
	Compressor Manufacturer		ZHUHAI LANDA COMPRESSOR CO.,LTD	
	Compressor Model		QXF-A102zE190B	
	Compressor Oil		FW68DA	
	Compressor Type		Rotary	
	Compressor LRA.	A		/
	Compressor RLA	A		4.6
	Compressor Power Input	W		1023
	Compressor Overload Protector			HPC115/95U1/KSD115°C
	Throttling Method			Electron expansion valve
	Set Temperature Range	°C		16~30
	Cooling Operation Ambient Temperature Range	°C		-15~43
	Heating Operation Ambient Temperature Range	°C		-15~24
	Condenser Form			Aluminum Fin-copper Tube
	Condenser Pipe Diameter	mm		Φ7.94
	Condenser Rows-fin Gap	mm		1-1.4
	Condenser Coil Length (LXDXW)	mm		731X19.05X550
	Fan Motor Speed	rpm		900
	Fan Motor Power Output	W		30
	Fan Motor RLA	A		0.36
	Fan Motor Capacitor	μF		/
	Outdoor Unit Air Flow Volume	m ³ /h		2200
	Fan Type			Axial-flow
	Fan Diameter	mm		Φ438
	Defrosting Method			Automatic Defrosting
	Climate Type			T1
	Isolation			I
	Moisture Protection			IPX4
	Permissible Excessive Operating Pressure for the Discharge Side	MPa		4.3
	Permissible Excessive Operating Pressure for the Suction Side	MPa		2.5
	Sound Pressure Level (H/M/L)	dB (A)		52/-/-
	Sound Power Level (H/M/L)	dB (A)		64/-/-
Dimension(WXHxD)	mm		848X596X320	
Dimension of Carton Box (LXWXH)	mm		878X360X630	
Dimension of Package(LXWXH)	mm		881X363X645	
Net Weight	kg		31	
Gross Weight	kg		34	
Refrigerant			R32	
Refrigerant Charge	kg		0.7	
Connection Pipe	Connection Pipe Length	m	5	
	Connection Pipe Gas Additional Charge	g/m	16	
	Outer Diameter Liquid Pipe	mm	Φ6	
	Outer Diameter Gas Pipe	mm	Φ9.52	
	Max Distance Height	m	10	
	Max Distance Length	m	20	
Note: The connection pipe applies metric diameter.				

The above data is subject to change without notice. Please refer to the nameplate of the unit.

Model			GWH09QA-K6DNB2A	GWH12QB-K6DNB2A	
Product Code			CB432025400	CB432025500	
Power Supply	Rated Voltage	V~	220-240	220-240	
	Rated Frequency	Hz	50	50	
	Phases		1	1	
Power Supply Mode			Outdoor	Outdoor	
Cooling Capacity		W	2500	3200	
Heating Capacity		W	2800	3400	
Cooling Power Input		W	720	991	
Heating Power Input		W	750	916	
Cooling Power Current		A	3.2	4.4	
Heating Power Current		A	3.2	4	
Rated Input		W	1500	1500	
Rated Current		A	6	6	
Rated Heating Current		A	7.5	7.5	
Air Flow Volume(SS/H/MH/M/ML/L/SL)		m ³ /h	500/420/390/300	590/480/410/280	
Dehumidifying Volume		L/h	0.80	1.4	
EER		W/W	3.47	3.23	
COP		W/W	3.73	3.71	
SEER		W/W	6.5	6.1	
HSPF		W/W	/	/	
Application Area		m ²	12-18	15-22	
Indoor Unit	Indoor Unit Model		GWH09QA-K6DNB2A/I	GWH12QB-K6DNB2A/I	
	Indoor Unit Product Code		CB432N25400	CB432N25500	
	Fan Type		Cross-flow	Cross-flow	
	Diameter Length(DXL)		mm	Φ98X507	Φ98X580
	Fan Motor Cooling Speed(SS/H/MH/M/ML/L/SL)		r/min	1300/1200/1000/800	1350/1200/1050/750
	Fan Motor Heating Speed(SS/H/MH/M/ML/L/SL)		r/min	1300/1200/1000/800	1350/1200/1050/850
	Output of Fan Motor		W	10	20
	Fan Motor RLA		A	0.2	0.22
	Fan Motor Capacitor		μF	1	1
	Input of Heater		W	/	/
	Evaporator Form			Aluminum Fin-copper Tube	Aluminum Fin-copper Tube
	Pipe Diameter		mm	Φ5	Φ5
	Row-fin Gap		mm	2-1.5	2-1.4
	Coil Length (LXD _X W)		mm	510X22.8X266.7	584X22.8X266.7
	Swing Motor Model			MP24AA	MP24AA
	Output of Swing Motor		W	1.5	MP24AA
	Fuse		A	3.15	3.15
	Sound Pressure Level(SS/H/MH/M/ML/L/SL)		dB (A)	Cooling:39/36/32/25 Heating:39/36/33/26	Cooling:41/37/33/24 Heating:42/38/33/27
	Sound Power Level(SS/H/MH/M/ML/L/SL)		dB (A)	Cooling:55/48/44/37 Heating:49/48/45/38	Cooling:57/50/45/34 Heating:53/51/46/39
	Dimension (WXH _X D)		mm	714X270X195	790×275×200
Dimension of Carton Box (LXWXH)		mm	760X334X259	850×339×262	
Dimension of Package (LXWXH)		mm	763X350X270	852×355×273	
Net Weight		kg	8	9	
Gross Weight		kg	9.5	11	

Outdoor Unit	Model of Outdoor Unit		GWH09AGA-K6DNA1A/O	GWH12AGB-K6DNA1A/O
	Product Code of Outdoor Unit		CB385W01000	CB385W01700
	Compressor Manufacturer/Trademark		ZHUHAI LANDA COMPRESSOR CO.,LTD	ZHUHAI LANDA COMPRESSOR CO., LTD
	Compressor Model		FTz-AN075ACBF-A	FTz-AN088ACBF-A
	Compressor Oil		FW68DA	FW68DA
	Compressor Type		Rotary	Rotary
	L.R.A.	A	/	/
	Compressor RLA	A	3.00	3.60
	Compressor Power Input	W	633	758
	Overload Protector		/	/
	Throttling Method		Capillary	Capillary
	Operation Temp	°C	16~30	16~30
	Ambient Temp (Cooling)	°C	-15~43	18~43
	Ambient Temp (Heating)	°C	-15~24	-15~24
	Condenser Form		Aluminum Fin-copper Tube	Aluminum Fin-copper Tube
	Pipe Diameter	mm	Φ7	Φ7
	Rows-fin Gap	mm	1-1.4	1-1.4
	Coil Length (LXD _{XW})	mm	700X19.05X528	700X19.05X528
	Fan Motor Speed	rpm	900	900
	Output of Fan Motor	W	30	30
	Fan Motor RLA	A	0.40	0.40
	Fan Motor Capacitor	μF	/	/
	Air Flow Volume of Outdoor Unit	m ³ /h	1950	1950
	Fan Type		Axial-flow	Axial-flow
	Fan Diameter	mm	Φ400	Φ400
	Defrosting Method		Automatic Defrosting	Automatic Defrosting
	Climate Type		T1	T1
	Isolation		I	I
	Moisture Protection		IPX4	IPX4
	Permissible Excessive Operating Pressure for the Discharge Side	MPa	4.3	4.3
	Permissible Excessive Operating Pressure for the Suction Side	MPa	2.5	2.5
	Sound Pressure Level (H/M/L)	dB (A)	51/-/-	51/-/-
Sound Power Level (H/M/L)	dB (A)	62/-/-	64/-/-	
Dimension (WXHXD)	mm	732X550X330	732X550X330	
Dimension of Carton Box (LXWXH)	mm	789X390X600	789X390X600	
Dimension of Package (LXWXH)	mm	792X393X615	792X393X615	
Net Weight	kg	25	25	
Gross Weight	kg	27.5	27.5	
Refrigerant		R32	R32	
Refrigerant Charge	kg	0.5	0.55	
Connection Pipe	Length	m	5	5
	Gas Additional Charge	g/m	16	16
	Outer Diameter Liquid Pipe	mm	Φ6	Φ6
	Outer Diameter Gas Pipe	mm	Φ9.52	Φ9.52
	Max Distance Height	m	10	10
	Max Distance Length	m	15	15
Note: The connection pipe applies metric diameter.				

The above data is subject to change without notice; please refer to the nameplate of the unit.

2.2 Operation Characteristic Curve

Cooling

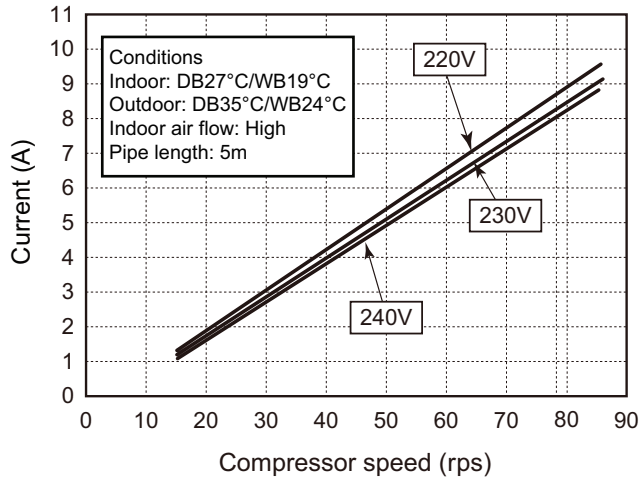

Heating

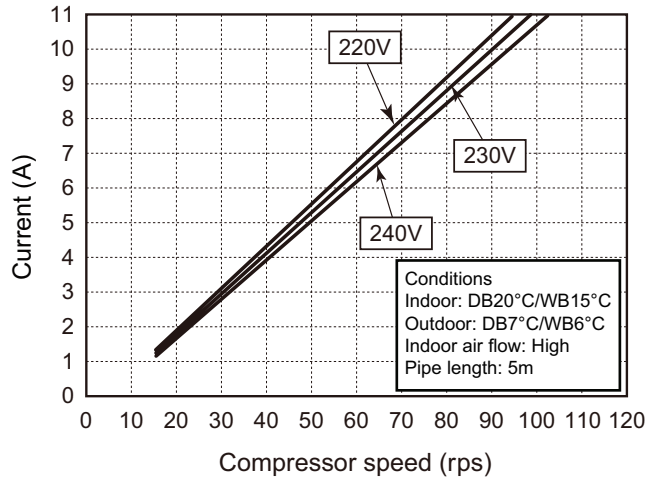

2.3 Capacity Variation Ratio According to Temperature

Heating operation ambient temperature range is -15°C~24°C

Cooling

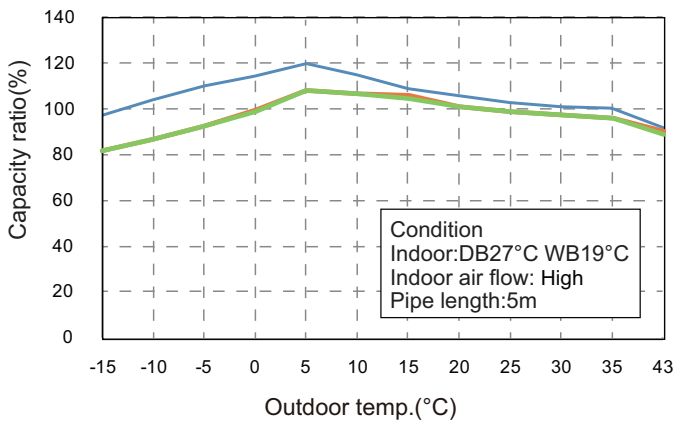

Heating

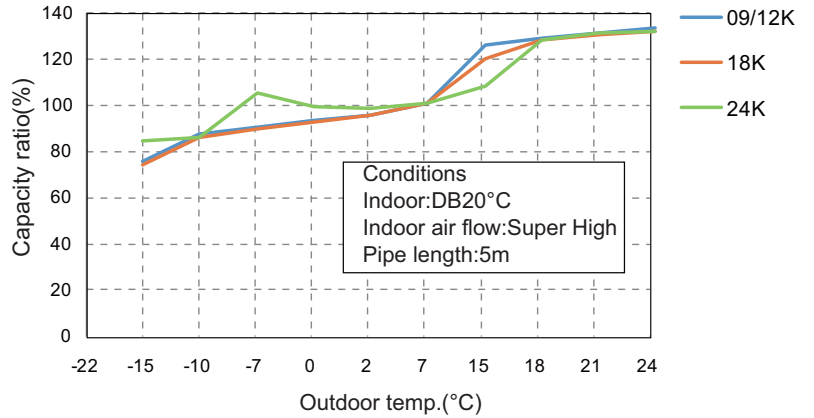

Heating operation ambient temperature range is -22°C~24°C

Cooling

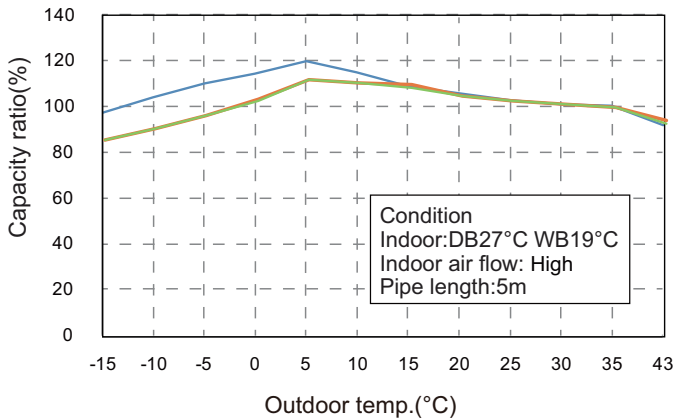

Heating

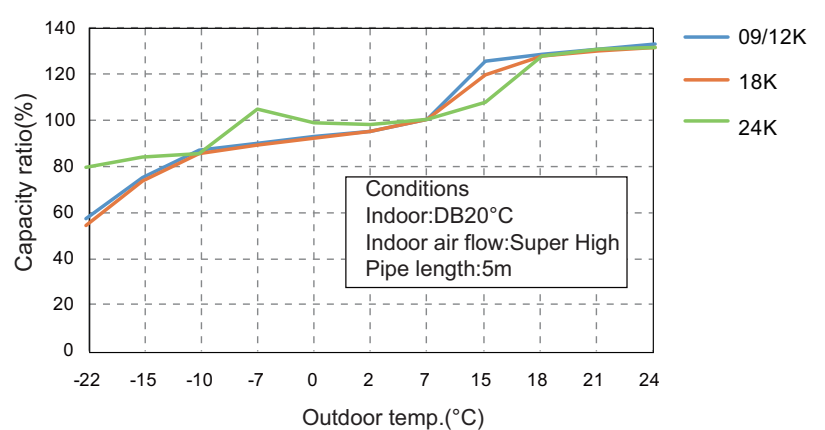

GWH09QA-K6DNB2A GWH12QB-K6DNB2A

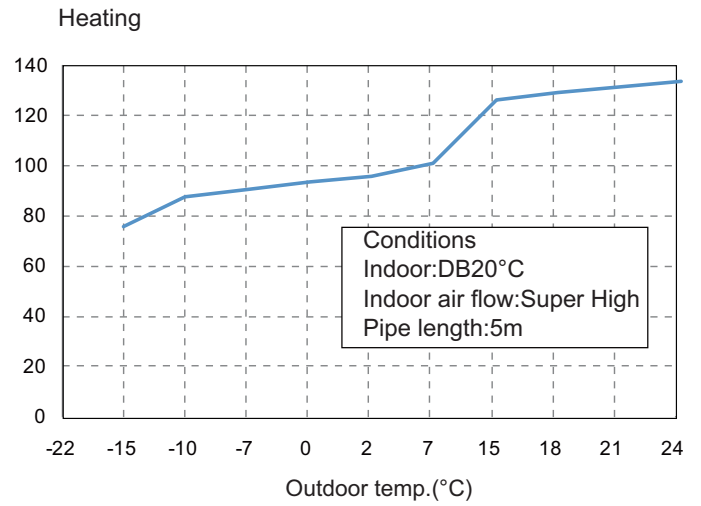
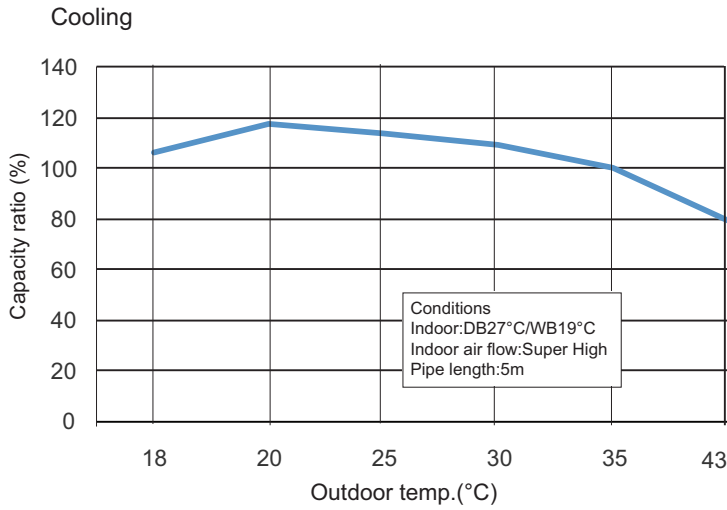

2.4 Cooling and Heating Data Sheet in Rated Frequency

Cooling:

Rated cooling condition(°C) (DB/WB)		Model	Pressure of gas pipe connecting indoor and outdoor unit	Inlet and outlet pipe temperature of heat exchanger		Fan speed of indoor unit	Fan speed of outdoor unit
Indoor	Outdoor			T1 (°C)	T2 (°C)		
27/19	35/24	09K	0.8 ~ 1.1	12 to 15	65 to 38	TURBO	High
		12K					
		18K	12 to 14	75 to 37			
		24K			0.9~ 1.1		

Heating:

Rated cooling condition(°C) (DB/WB)		Model	Pressure of gas pipe connecting indoor and outdoor unit	Inlet and outlet pipe temperature of heat exchanger		Fan speed of indoor unit	Fan speed of outdoor unit
Indoor	Outdoor			T1 (°C)	T2 (°C)		
20/-	7/6	09K	2.8 ~ 3.2	35 to 63	2 to 5	TURBO	High
		12K					
		18K	70 to 35	2 to 4			
		24K			2.2~ 2.4		

Instruction:

T1: Inlet and outlet pipe temperature of evaporator

T2: Inlet and outlet pipe temperature of condenser

P: Pressure at the side of big valve

Connection pipe length: 5 m.

2.5 Noise Curve

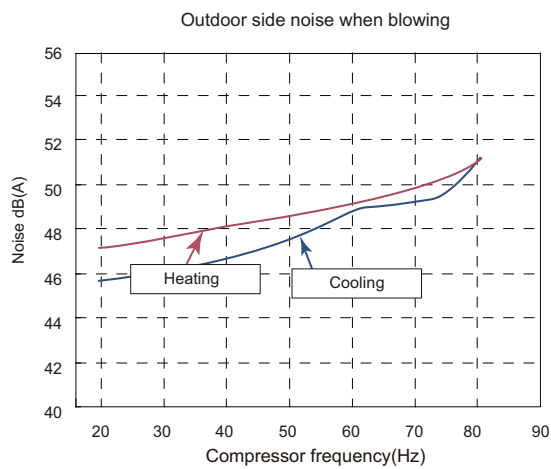
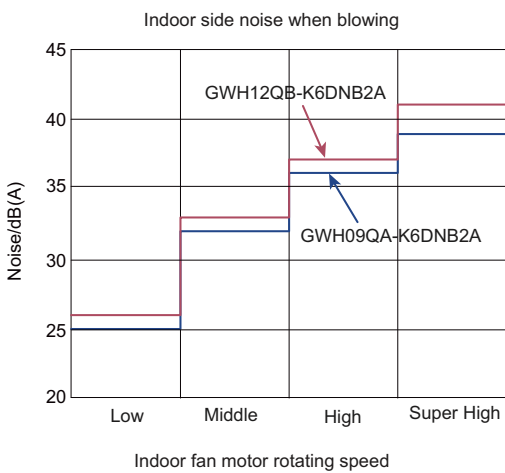
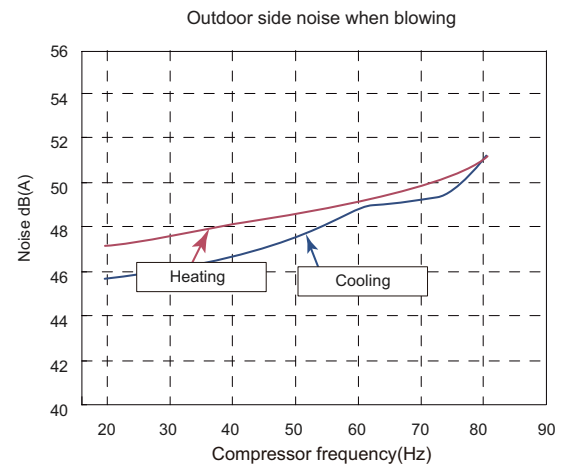
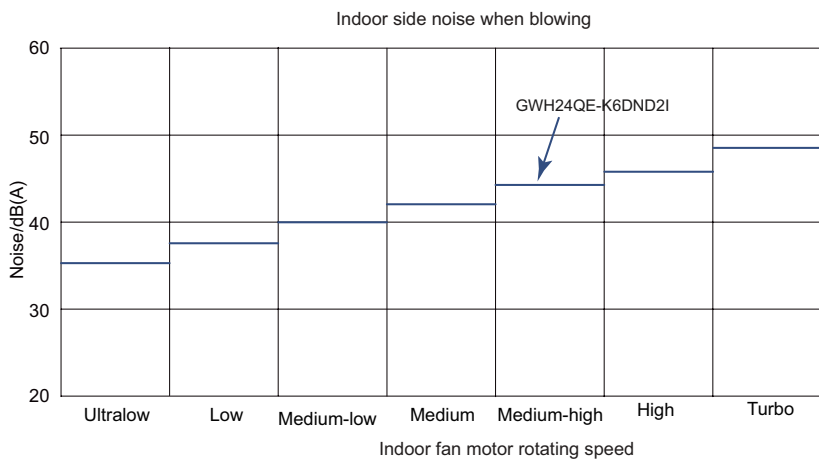
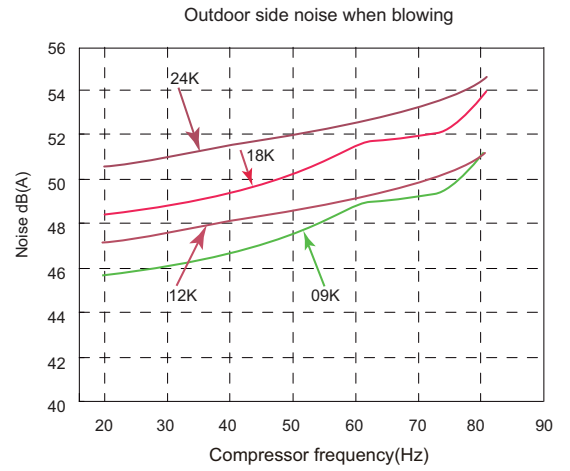
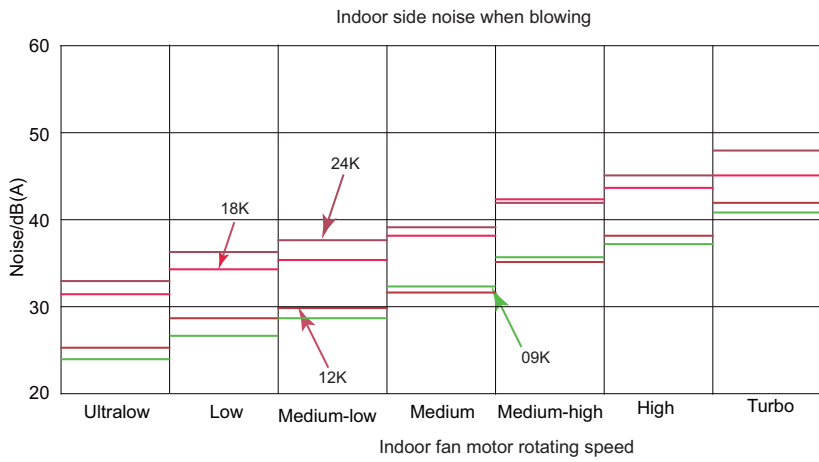

3. Outline Dimension Diagram

3.1 Indoor Unit

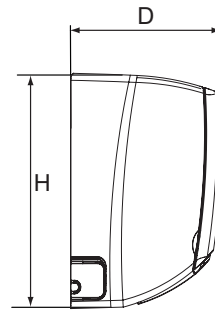
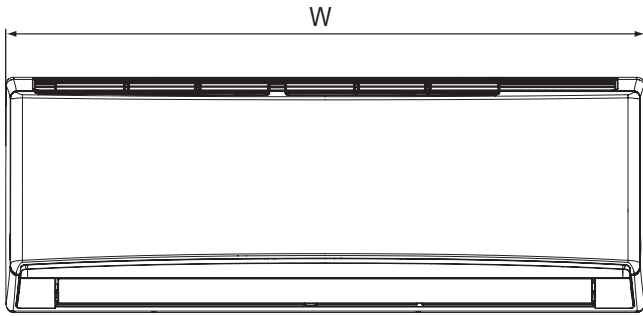

QA/QB

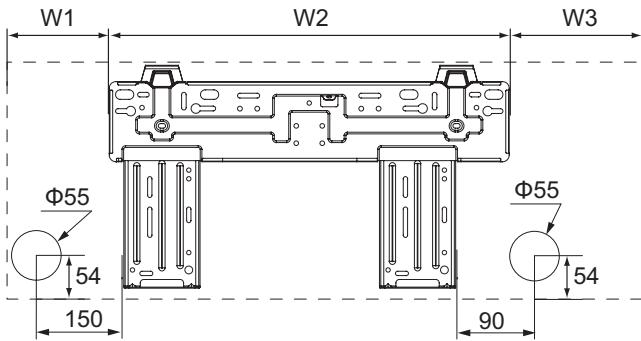

QC

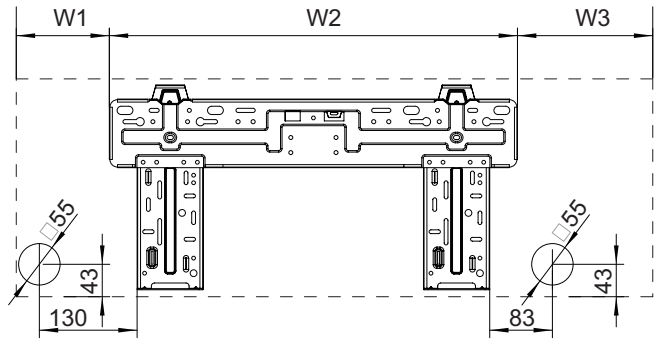

QD

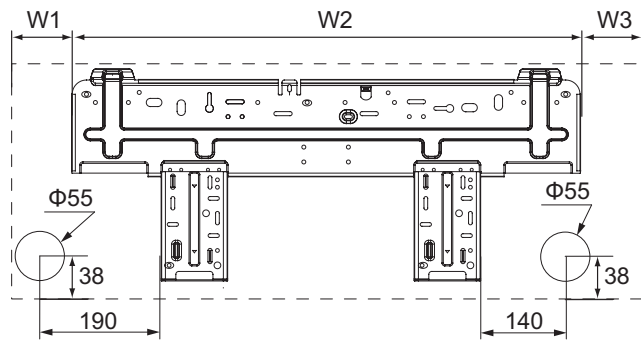

QE

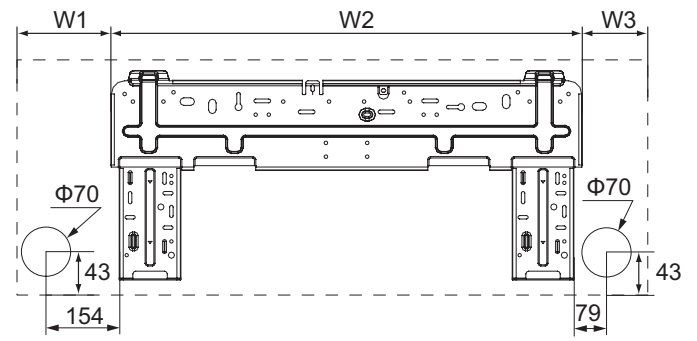

Unit:mm

Model	W	H	D	W1	W2	W3
QA	714	270	195	148	462	104
QB	790	275	200	168.5	462	159.5
QC	845	289	209	123	542	180
QD	970	300	224	104	685	181
QE	1078	325	246	206	685	187

3.2 Outdoor Unit

GWH09YC-K6DNA1A/O GWH12YC-K6DNA1A/O GWH12QC-K6DNA1D/O GWH12QC-K6DNA5X/O

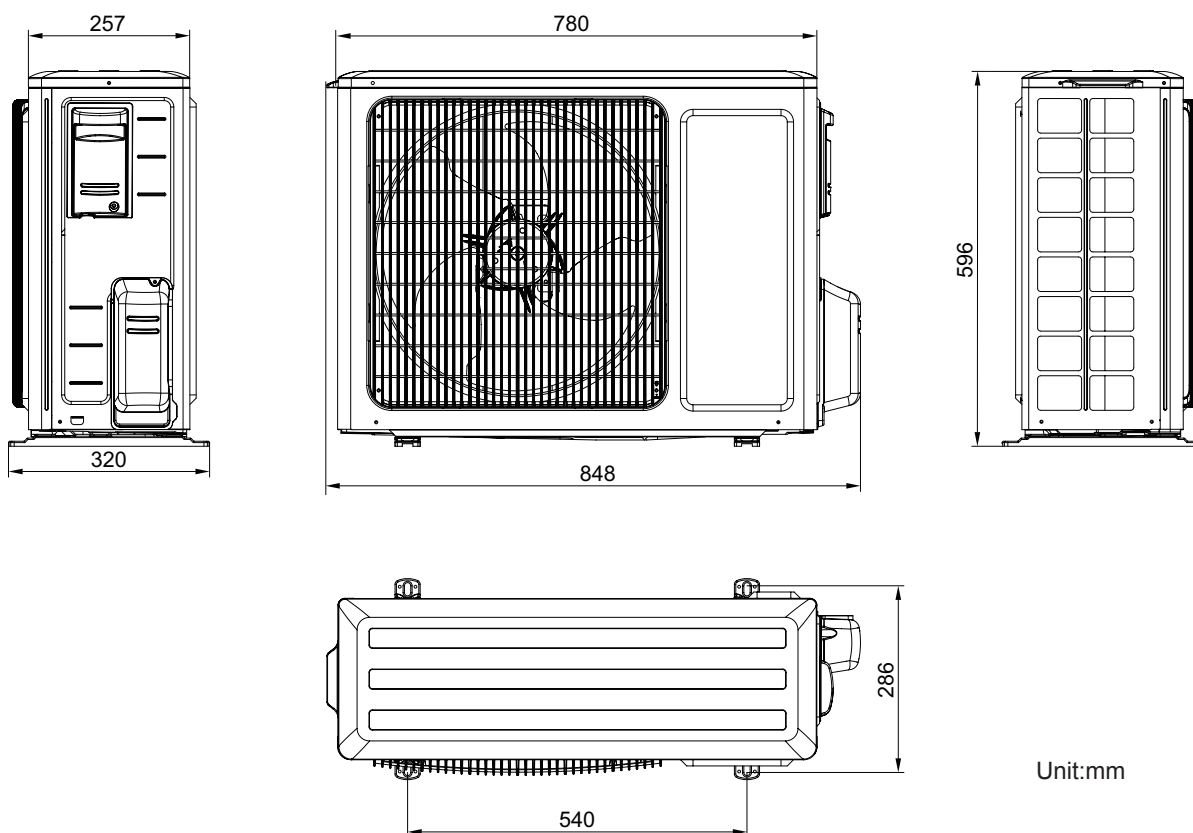

Unit:mm

GWH18QD-K6DNA1D/O GWH24QE-K6DNA1E/O GWH24QE-K6DNA5X/O GWH18QD-K6DNA5X/O GWH24YE-K6DNA1A/O

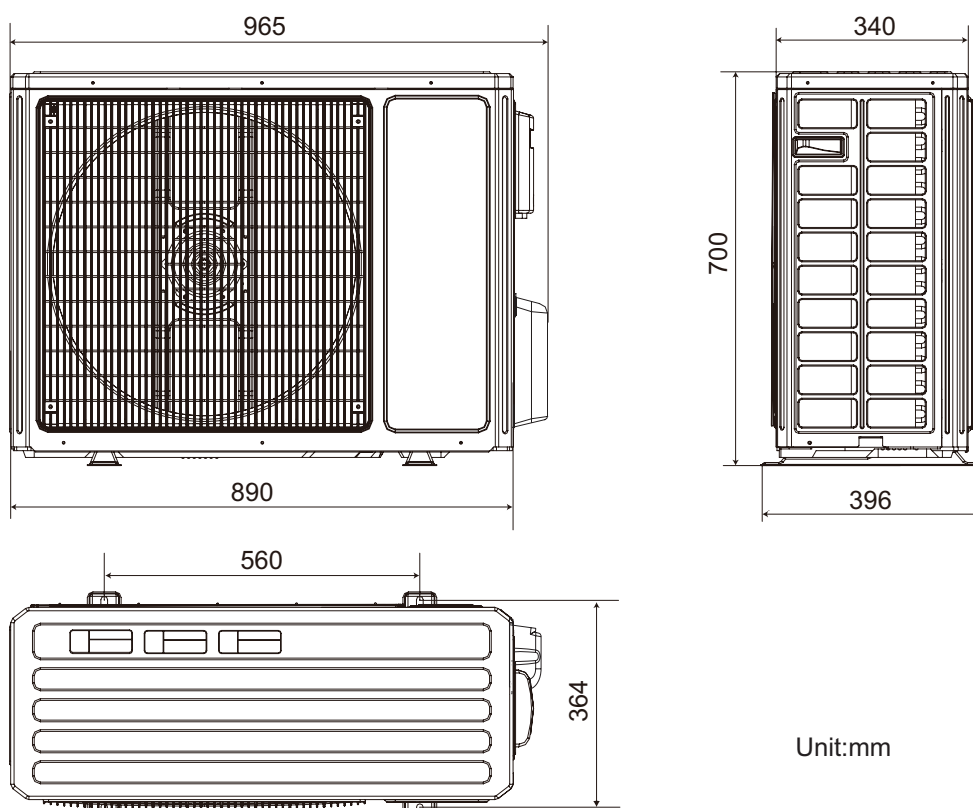

Unit:mm

GWH09QB-K6DNA1E/O

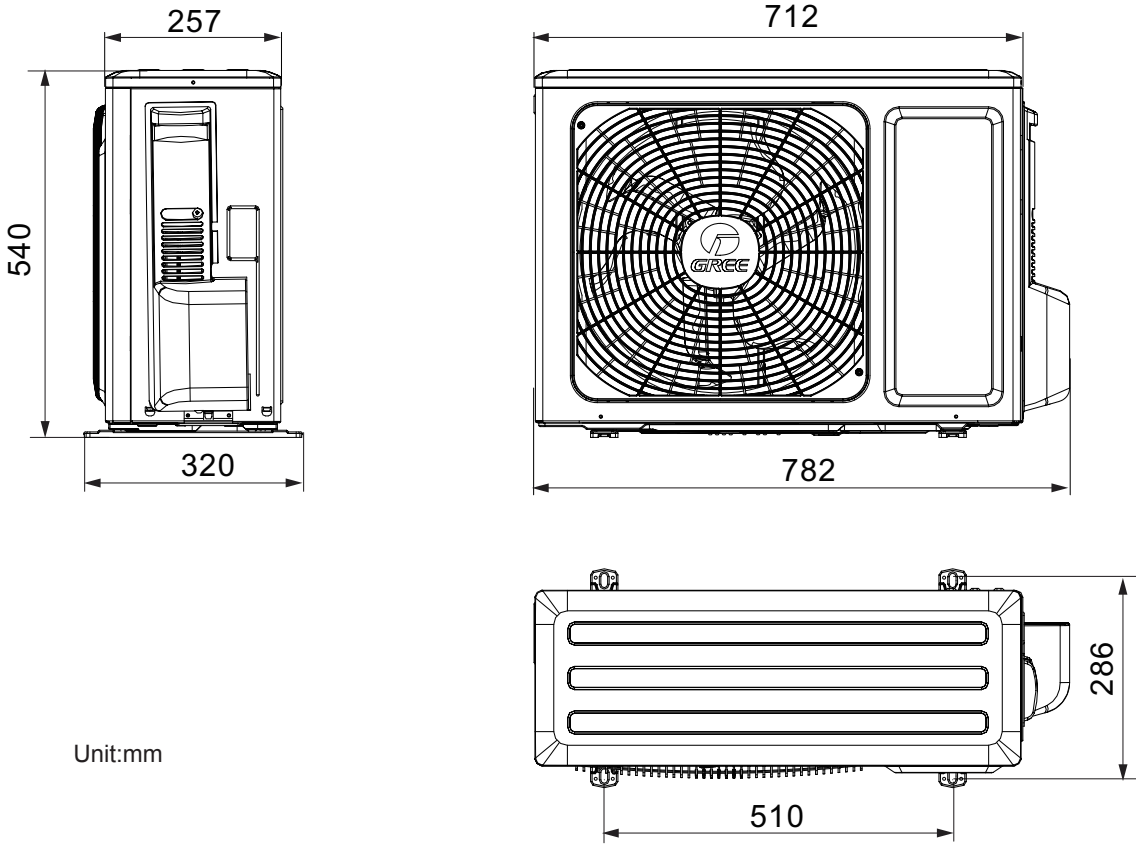

GWH18YD-K6DNA1A/O(CB437W01300)

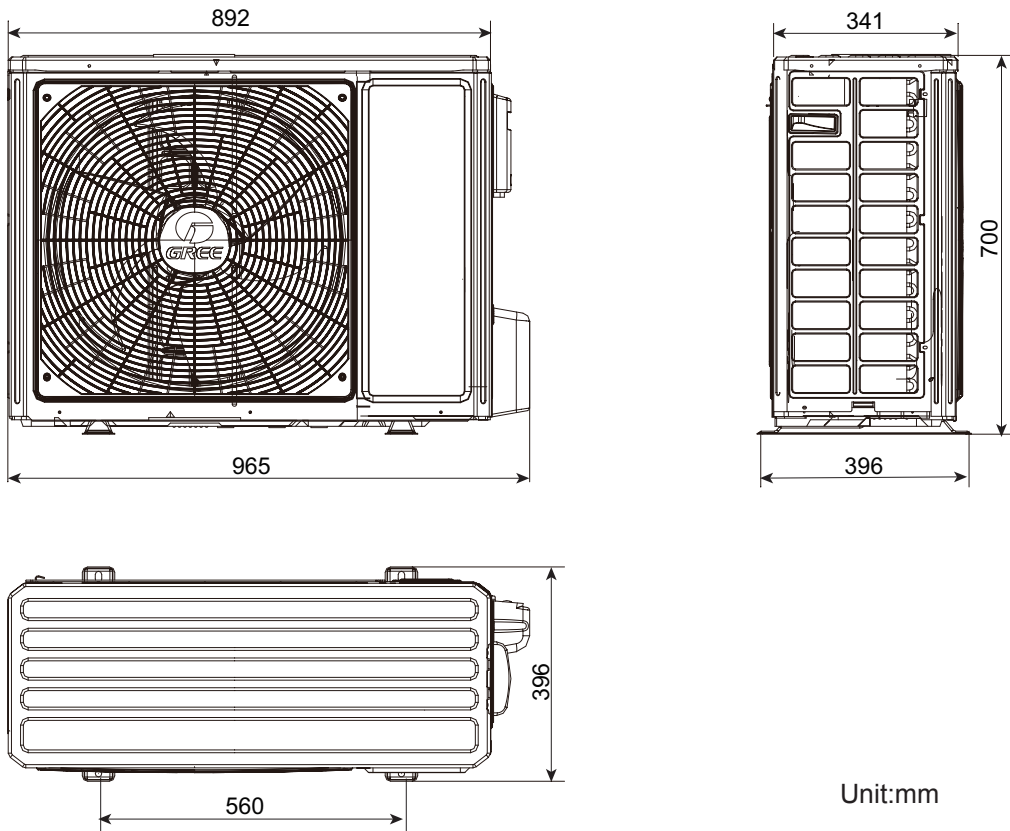

GWH09AGA-K6DNA1A/O GWH12AGB-K6DNA1A/O

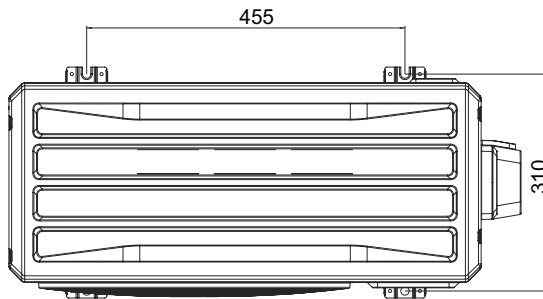
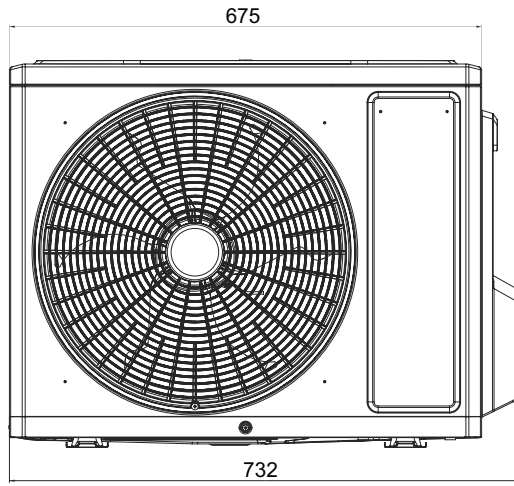
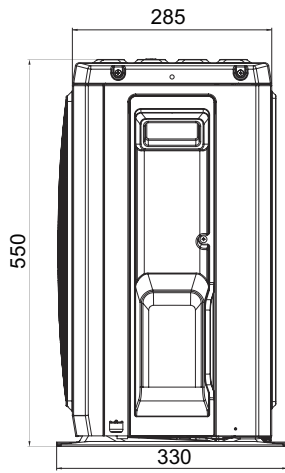

Unit:mm

4. Refrigerant System Diagram

All models except: GWH09QB-K6DNA1E/O GWH18YD-K6DNA1A/O GWH24YE-K6DNA1A/O
GWH09AGA-K6DNA1A/O GWH12AGB-K6DNA1A/O

Cooling and heating model

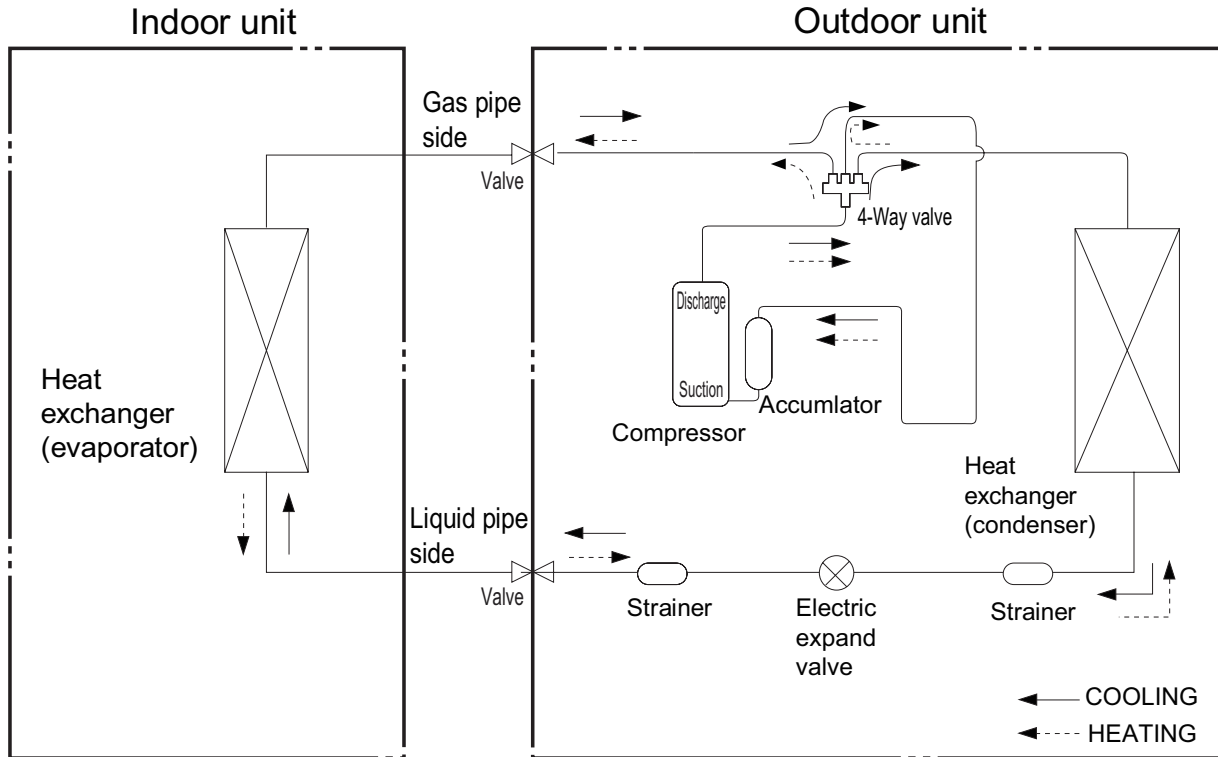

GWH09QB-K6DNA1E/O GWH09AGA-K6DNA1A/O GWH12AGB-K6DNA1A/O

Cooling and heating model

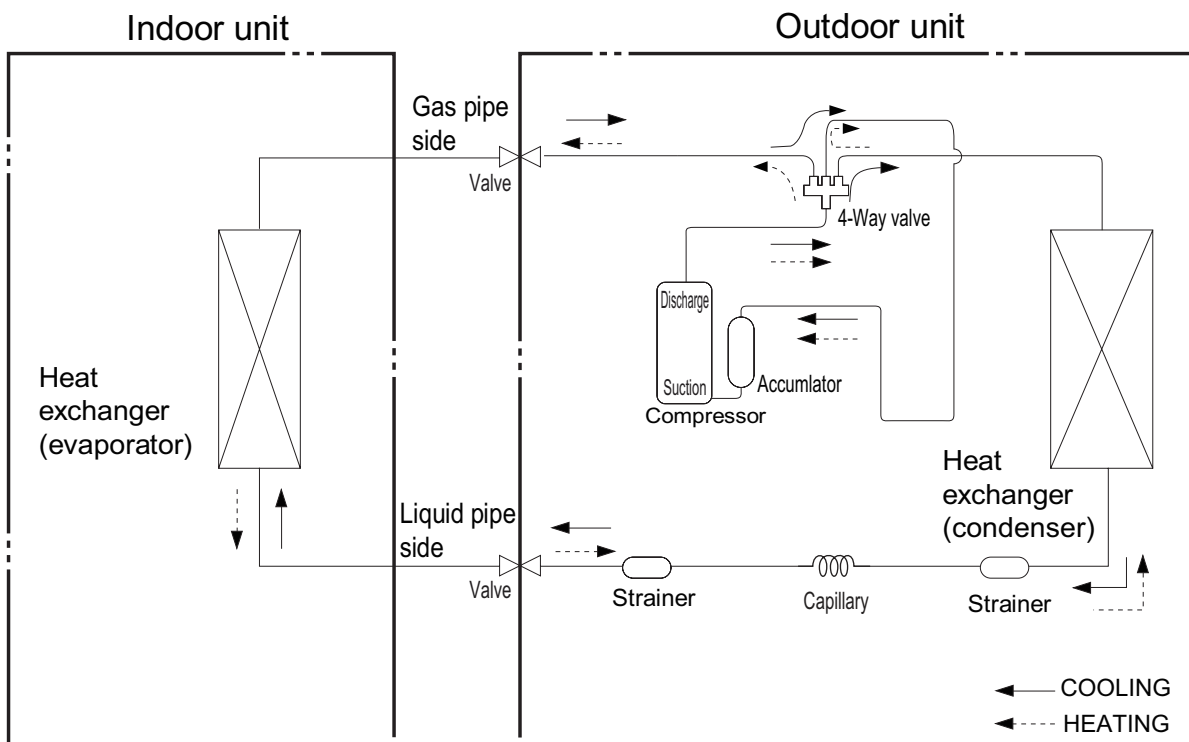

Connection pipe specification:

Liquid pipe: 1/4"

Gas pipe: 3/8" (09/12K)

Gas pipe: 1/2" (18K)

Gas pipe: 5/8" (24K)

GWH18YD-K6DNA1A/O GWH24YE-K6DNA1A/O

Cooling and heating model

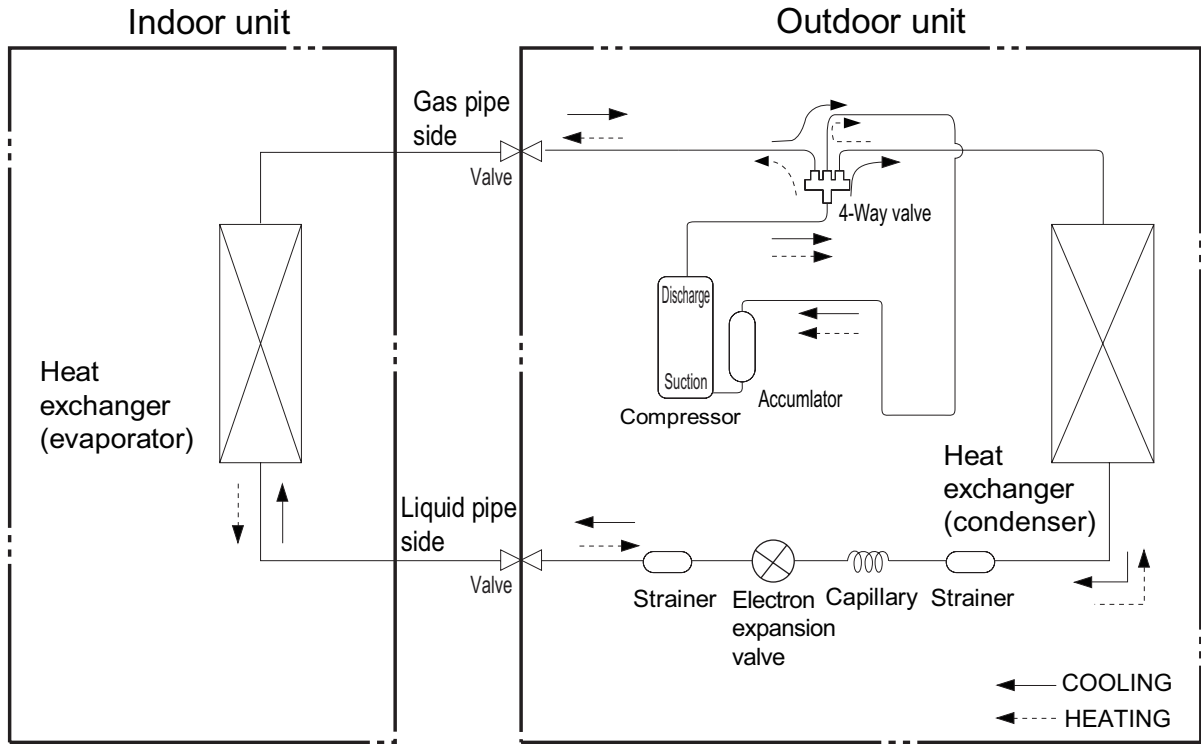

Connection pipe specification:
 Liquid pipe: 1/4" (6mm)
 Gas pipe: 1/2" (12mm)18K

5. Electrical Part

5.1 Wiring Diagram

• Instruction

Symbol	Symbol Color	Symbol	Symbol Color	Symbol	Name
WH	White	GN	Green	CAP	Jumper cap
YE	Yellow	BN	Brown	COMP	Compressor
RD	Red	BU	Blue		Grounding wire
YEGN	Yellow/Green	BK	Black		/
VT	Violet	OG	Orange		/

Note: Jumper cap is used to determine fan speed and the swing angle of horizontal louver for this model.

• Indoor Unit

All models except:

GWH09QB-K6DNC4E/(CB444N09600) GWH09QB-K6DNC6E/(CB443N06000) GWH12QC-K6DNC6D/(CB443N05700)
 GWH18QD-K6DNC6D/(CB443N05800) GWH24QE-K6DNC6E/(CB443N05900)GWH09QB-K6DNC2E/I GWH12QC-K6DNC2D/I
 GWH18QD-K6DNC2D/I GWH24QE-K6DNC2E/I GWH09QB-K6DNC4E/I GWH12QC-K6DNC4D/I GWH09QB-K6DNC8E/I(CB438N10101)
 GWH12QC-K6DNC8D/I(CB438N10202) GWH24QE-K6DNC8E/I(CB438N10401) GWH18QD-K6DNC4D/I(CB434N12501)
 GWH24QE-K6DNC4E/I(CB434N12403) GWH18QD-K6DNC8D/I(CB438N10301) GWH09QC-K6DNC2A/I(CB439N14100)
 GWH12QC-K6DNC2A/I(CB439N14200) GWH09QC-K6DND2A/I(CB461N06600) GWH12QC-K6DND2A/I(CB461N06500)
 GWH09QB-K6DNC4E/I(CB444N09602) GWH09QB-K6DNE4E/I(CB470N02702) GWH12QC-K6DNE4D/I(CB470N02902)
 GWH18QD-K6DNE4D/I(CB470N03001) GWH24QE-K6DNE4E/I(CB470N02801) GWH24QE-K6DNC4E/I(CB434N12402)
 GWH24QE-K6DNC6E/I(CB443N05902) GWH24QE-K6DNA5E/I(CB425N12202) GWH09QB-K6DNA5E/I(CB425N12502)
 GWH12QC-K6DNA5D/I(CB425N12302) GWH18QD-K6DNA5D/I(CB425N12402) GWH24QE-K6DNA5E/I(CB425N12203)
 GWH09QB-K6DNA2E/I GWH18QD-K6DNC4D/I(CB444N12300) GWH24QE-K6DNC4E/I(CB444N09801)
 GWH24QE-K6DNC2E/I(CB439N13001) GWH18QD-K6DND2A/I(CB461N06700) GWH24QE-K6DND2I/I(CB461N06800)
 GWH09QA-K6DNC2A/I(CB432N25400) GWH12QB-K6DNC2A/I(CB432N25500)

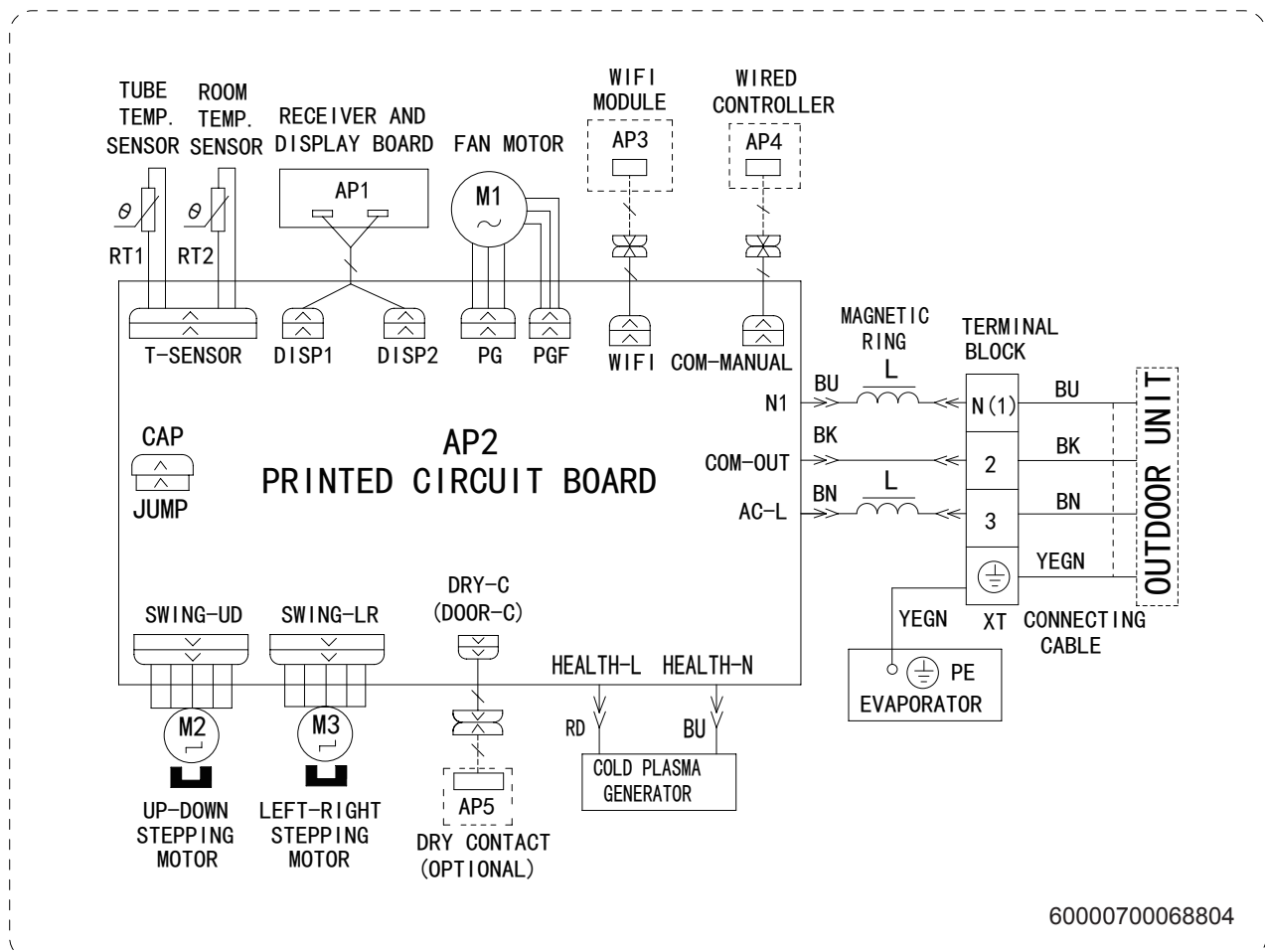

GWH09QB-K6DNC4E/I(CB444N09600) GWH09QB-K6DNC6E/I(CB443N06000) GWH12QC-K6DNC6D/I(CB443N05700)
 GWH18QD-K6DNC6D/I(CB443N05800) GWH24QE-K6DNC6E/I(CB443N05900)GWH09QB-K6DNB2E/I GWH12QC-K6DNB2D/I
 GWH18QD-K6DNB2D/I GWH24QE-K6DNB2E/I GWH09QB-K6DNB4E/I GWH12QC-K6DNB4D/I GWH09QB-K6DNB8E/I(CB438N10101)
 GWH12QC-K6DNB8D/I(CB438N10202) GWH24QE-K6DNB8E/I(CB438N10401) GWH18QD-K6DNB4D/I(CB434N12501)
 GWH24QE-K6DNB4E/I(CB434N12403) GWH18QD-K6DNB8D/I(CB438N10301)

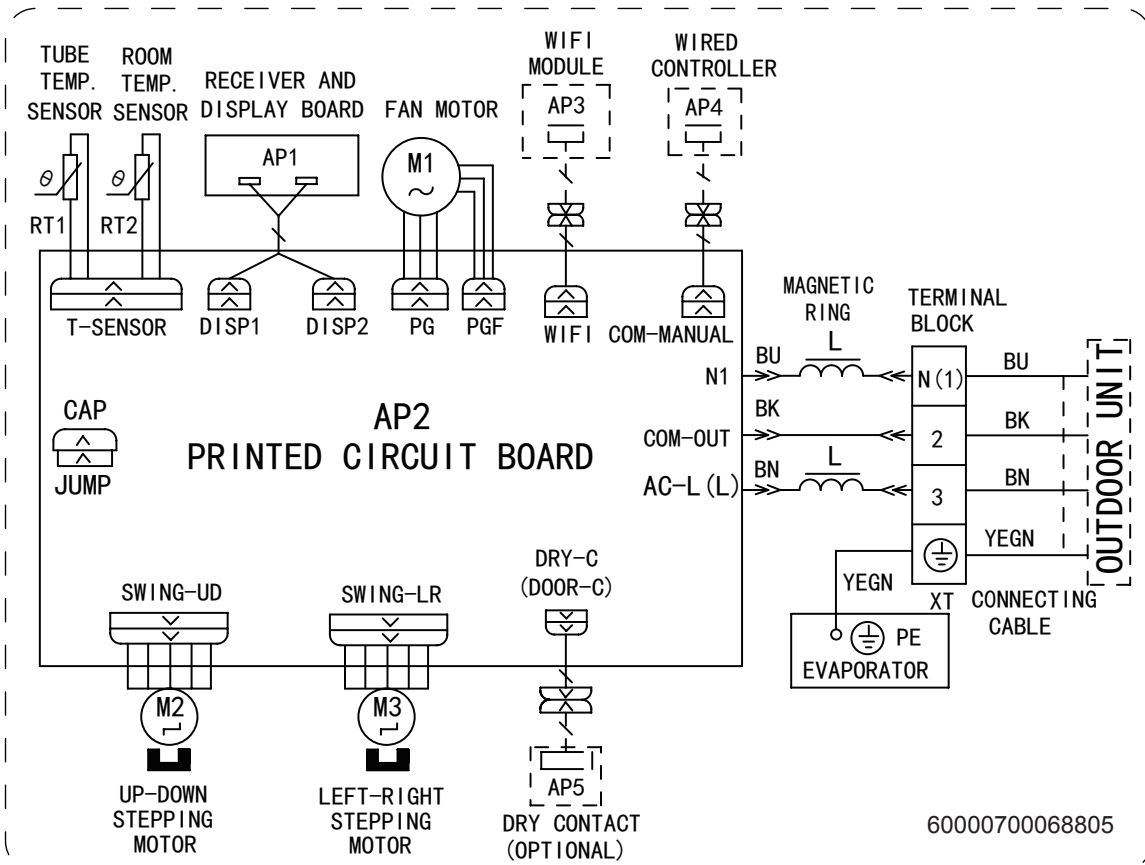

GWH09QB-K6DNC4E/I(CB444N09602) GWH09QB-K6DNE4E/I(CB470N02702) GWH12QC-K6DNE4D/I(CB470N02902)
 GWH18QD-K6DNE4D/I(CB470N03001) GWH24QE-K6DNE4E/I(CB470N02801) GWH24QE-K6DNB4E/I(CB434N12402)
 GWH24QE-K6DNC6E/I(CB443N05902) GWH24QE-K6DNA5E/I(CB425N12202) GWH09QB-K6DNA5E/I(CB425N12502)
 GWH12QC-K6DNA5D/I(CB425N12302) GWH18QD-K6DNA5D/I(CB425N12402) GWH24QE-K6DNA5E/I(CB425N12203)
 GWH09QB-K6DNA2E/I

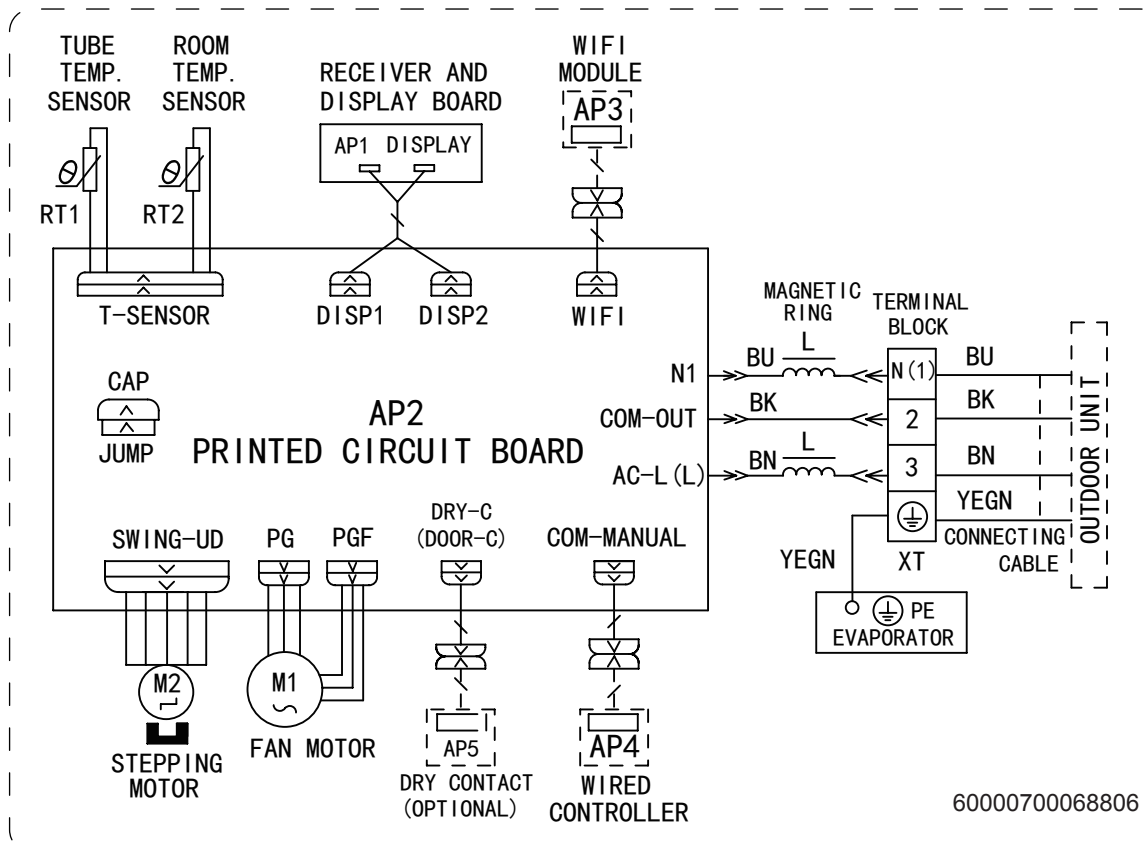

GWH09QC-K6DNC2A/I(CB439N14100) GWH12QC-K6DNC2A/I(CB439N14200)
 GWH09QC-K6DND2A/I(CB461N06600) GWH12QC-K6DND2A/I(CB461N06500)

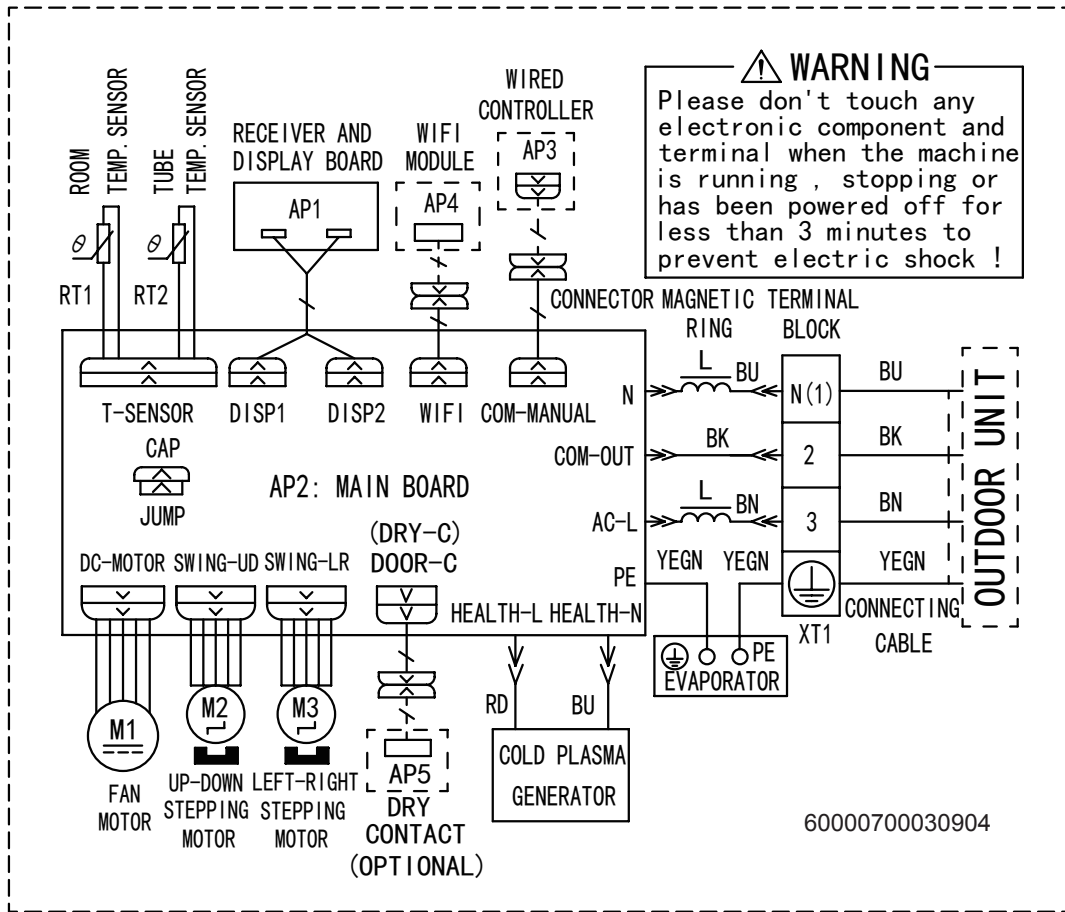

GWH18QD-K6DNC4D/I(CB444N12300) GWH24QE-K6DNC4E/I(CB444N09801)
 GWH24QE-K6DNC2E/I(CB439N13001)

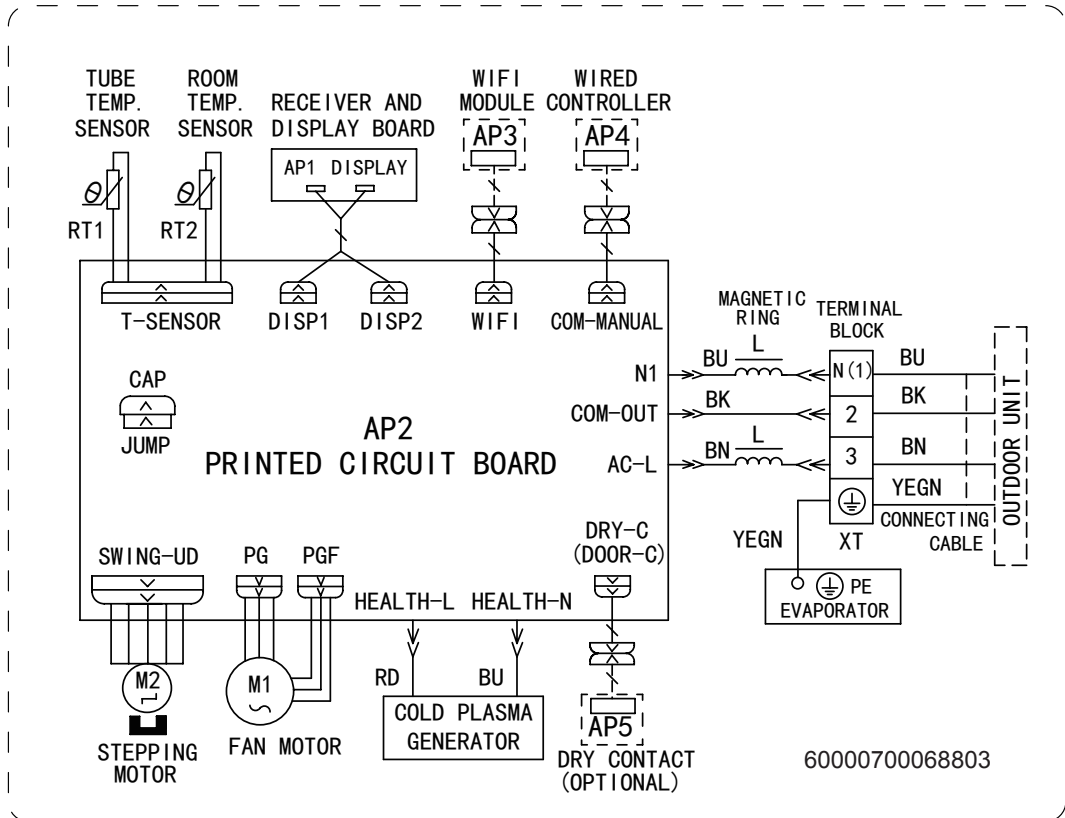

GWH18QD-K6DND2A/I(CB461N06700) GWH24QE-K6DND2I/I(CB461N06800)

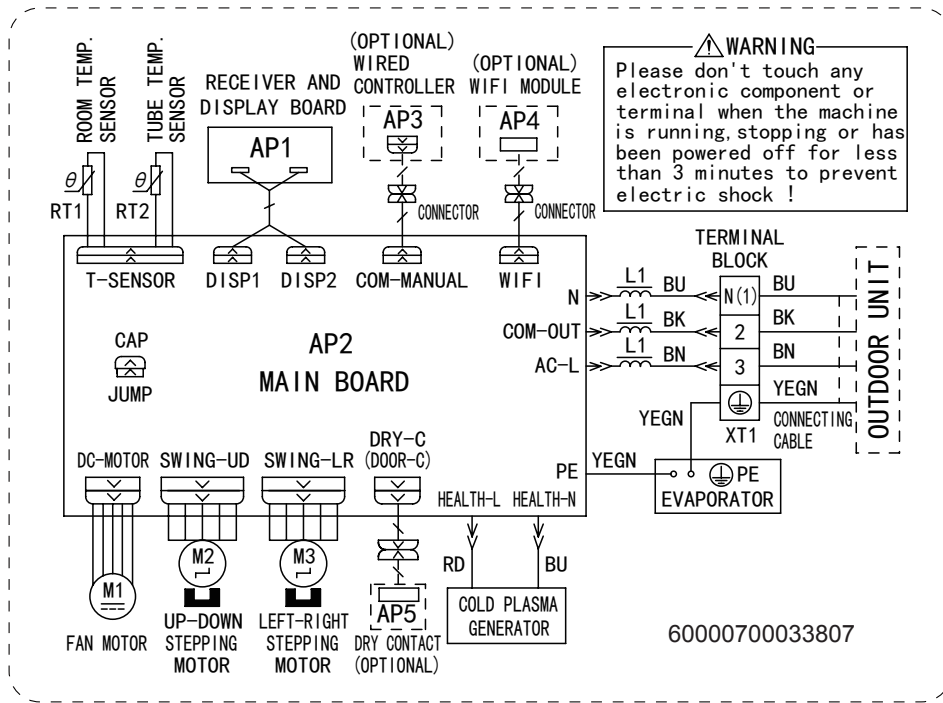

GWH09QA-K6DNB2A/I(CB432N25400) GWH12QB-K6DNB2A/I(CB432N25500)

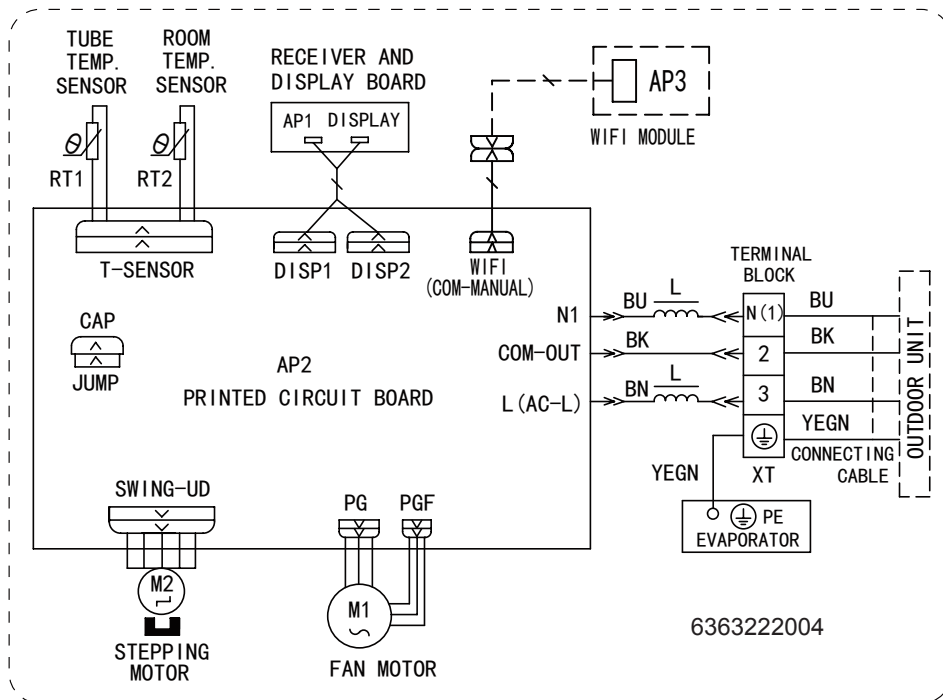

• Outdoor Unit

GWH09YC-K6DNA1A/O(CB437W01600) GWH12YC-K6DNA1A/O(CB437W01100)

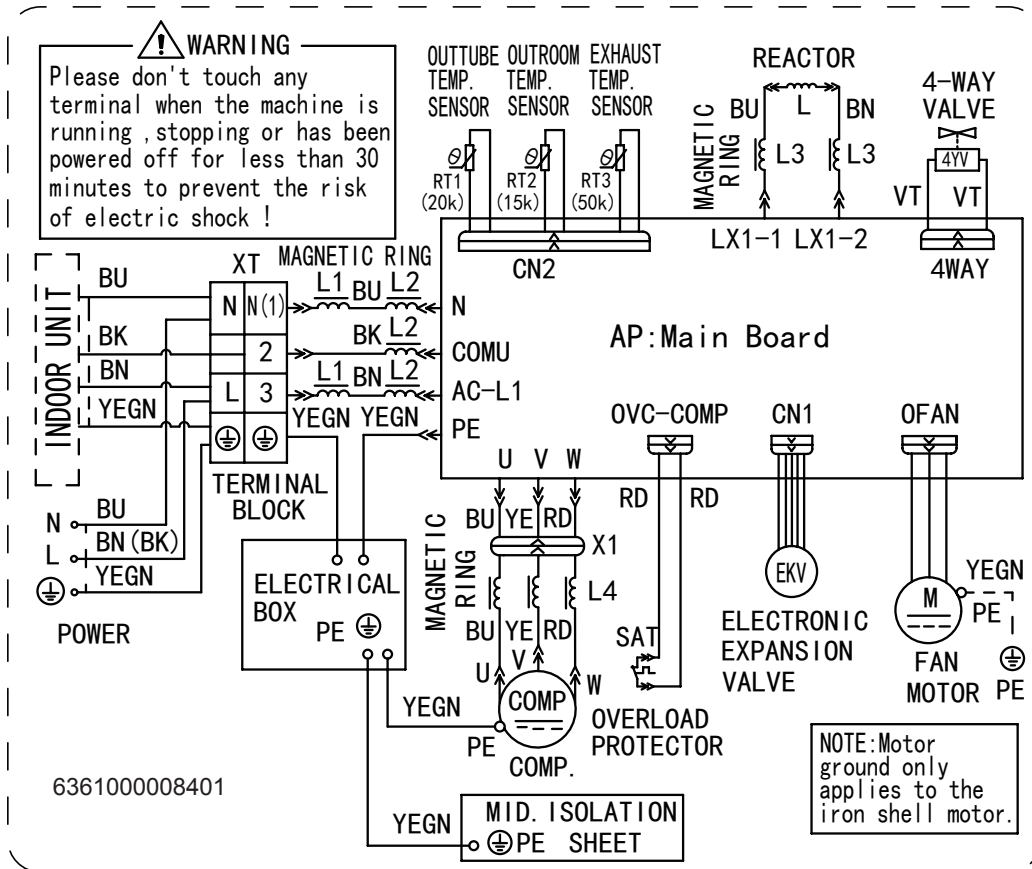

GWH24QE-K6DNA1E/O(CB419W15701) GWH24QE-K6DNA5X/O(CB425W15400)
GWH24YE-K6DNA1A/O(CB437W01400)

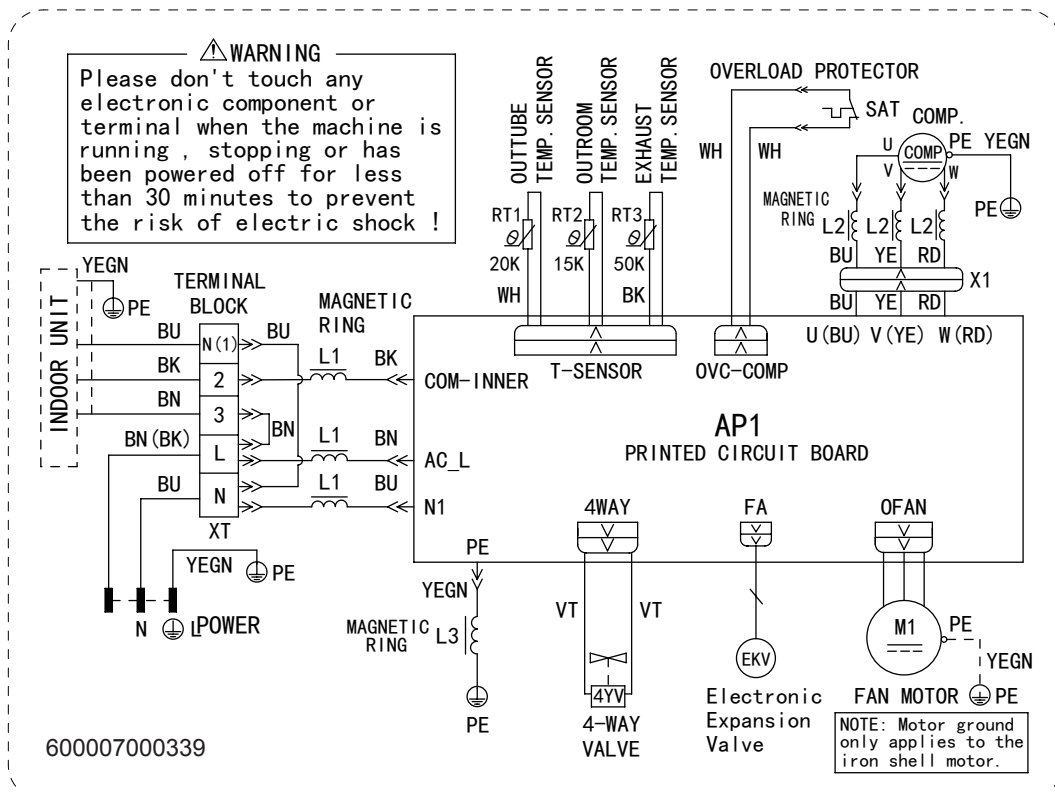

GWH09QB-K6DNA1E/O(CB419W15801)

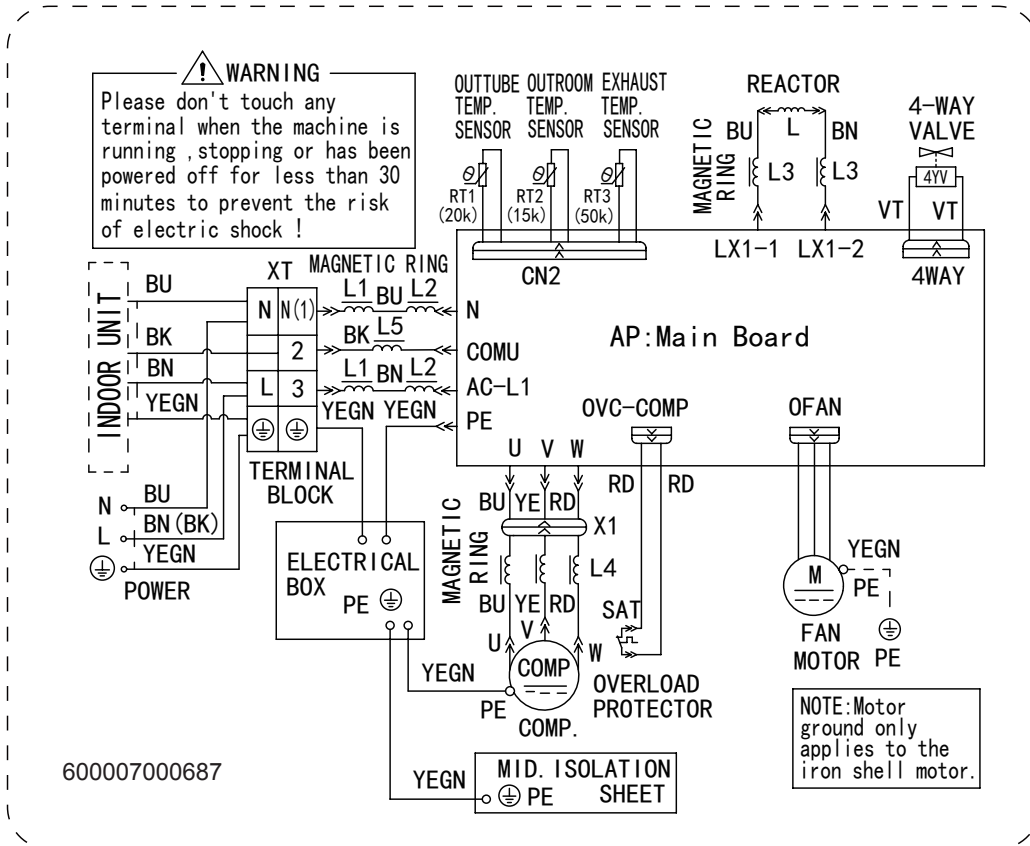

GWH09QB-K6DNA1E/O(CB419W15800)

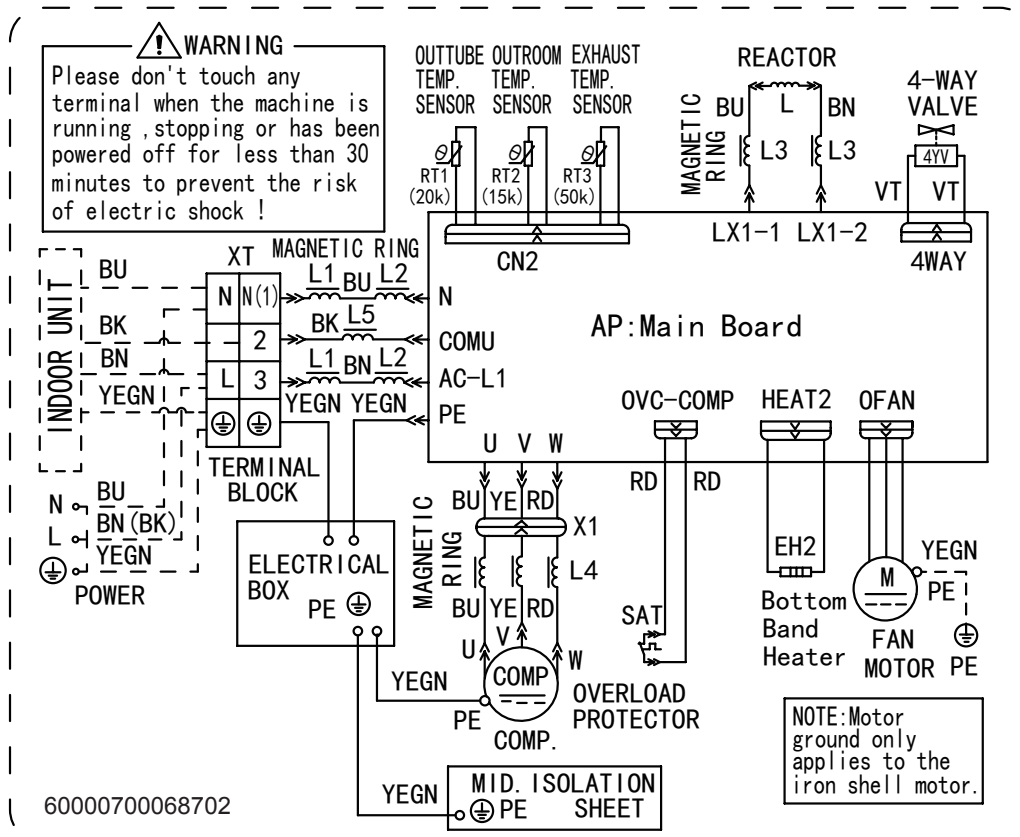

GWH12QC-K6DNA1D/O(LC)(CB419W15501) GWH12QC-K6DNA5X/O(CB425W15500)

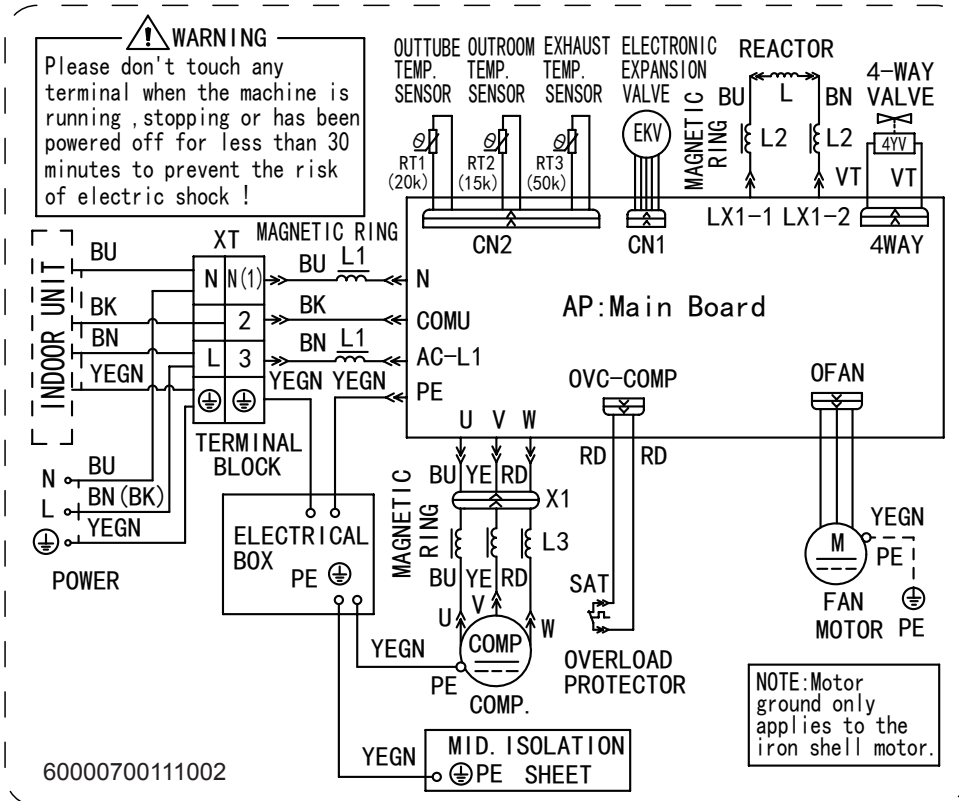

GWH12QC-K6DNA1D/O(LCLH) (CB419W15500)

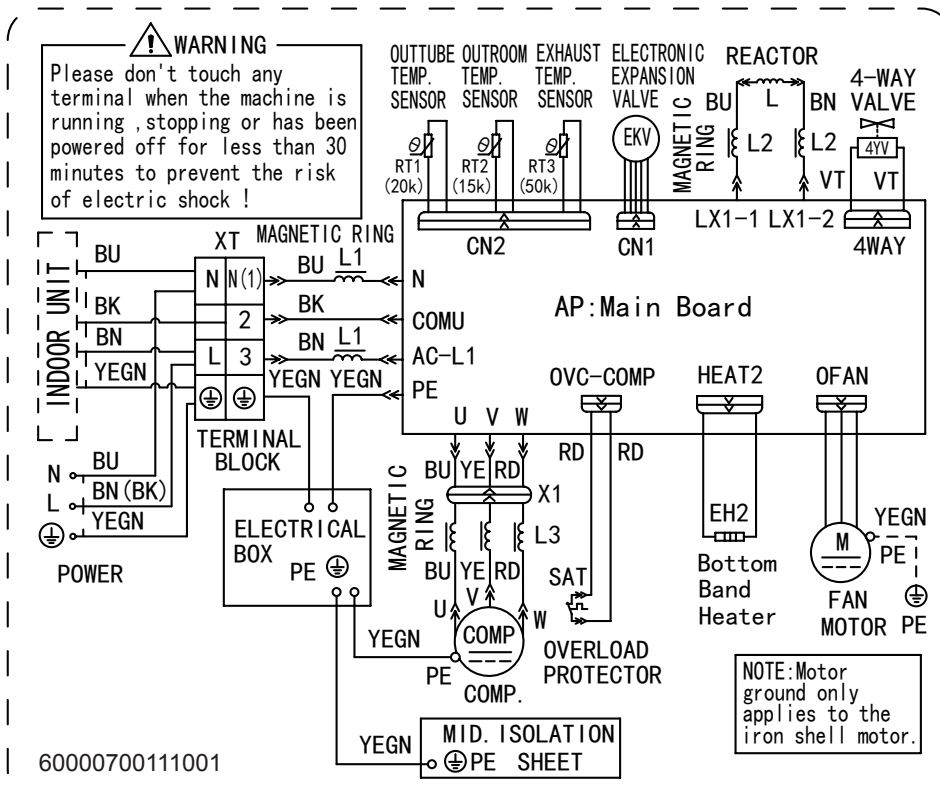

GWH18QD-K6DNA1D/O(CB419W15601) GWH18QD-K6DNA5X/O(CB425W15300)

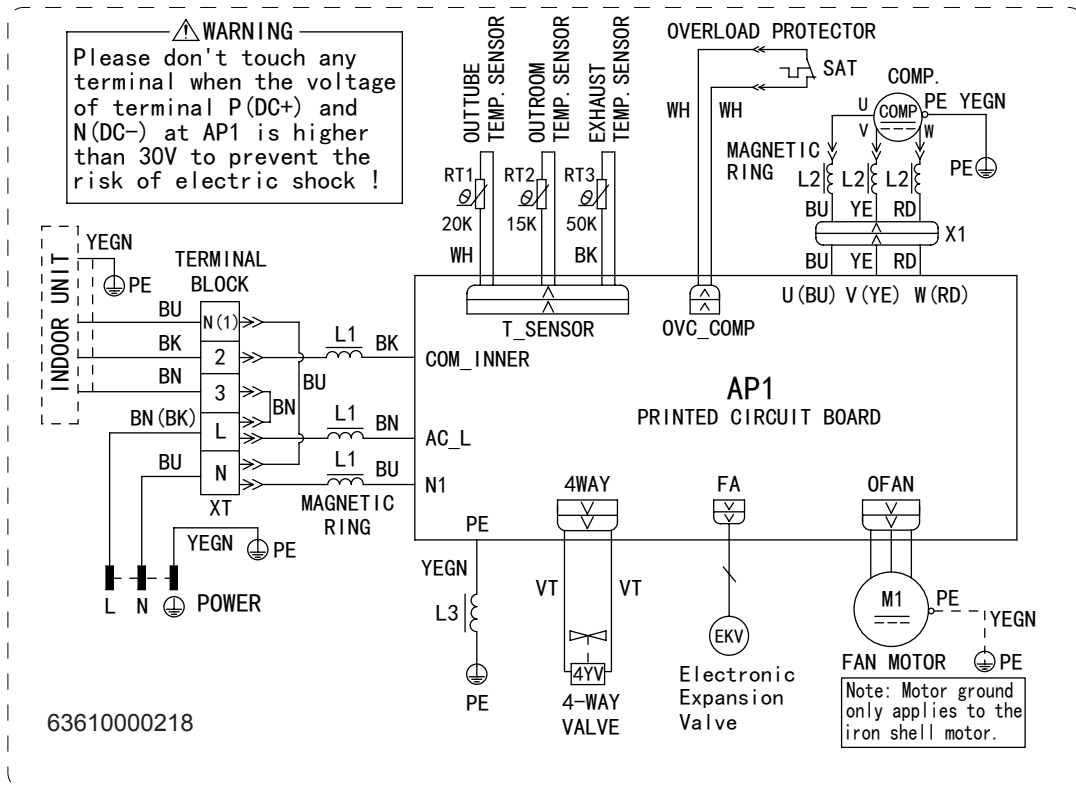

GWH18QD-K6DNA1D/O(CB419W15600)

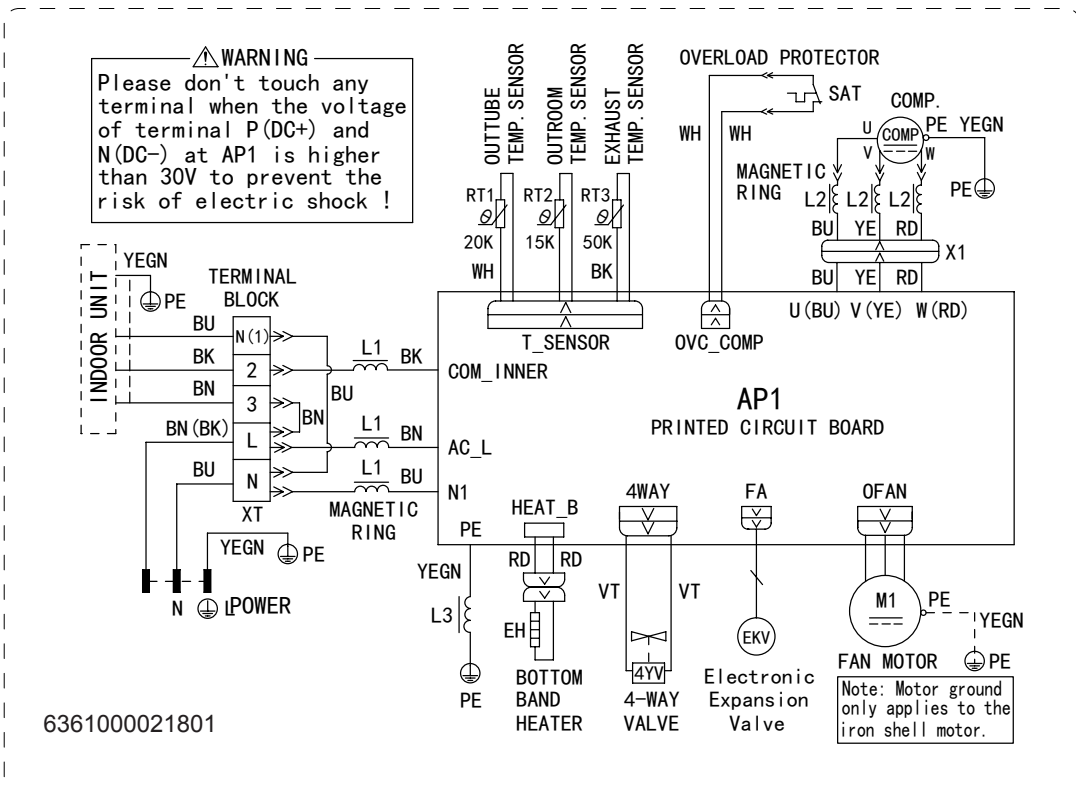

GWH24QE-K6DNA1E/O(CB419W15700)

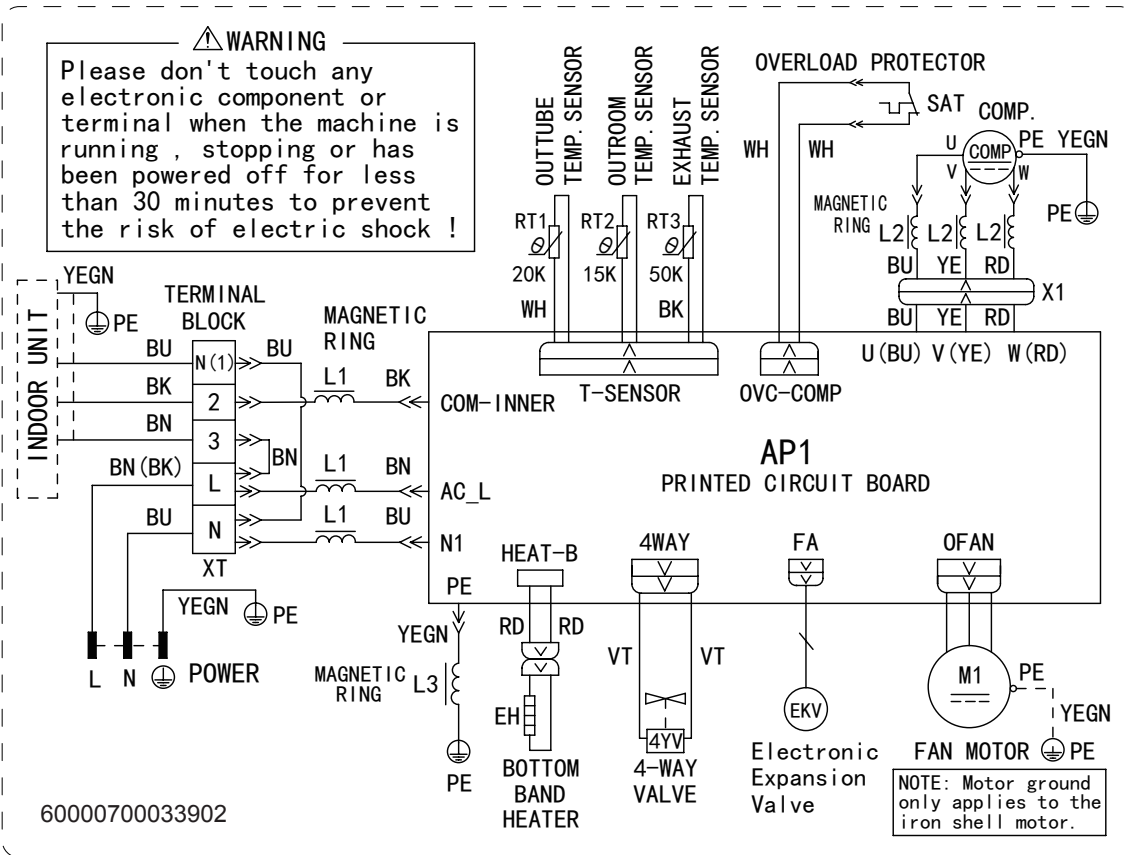

GWH18YD-K6DNA1A/O(CB437W01300)

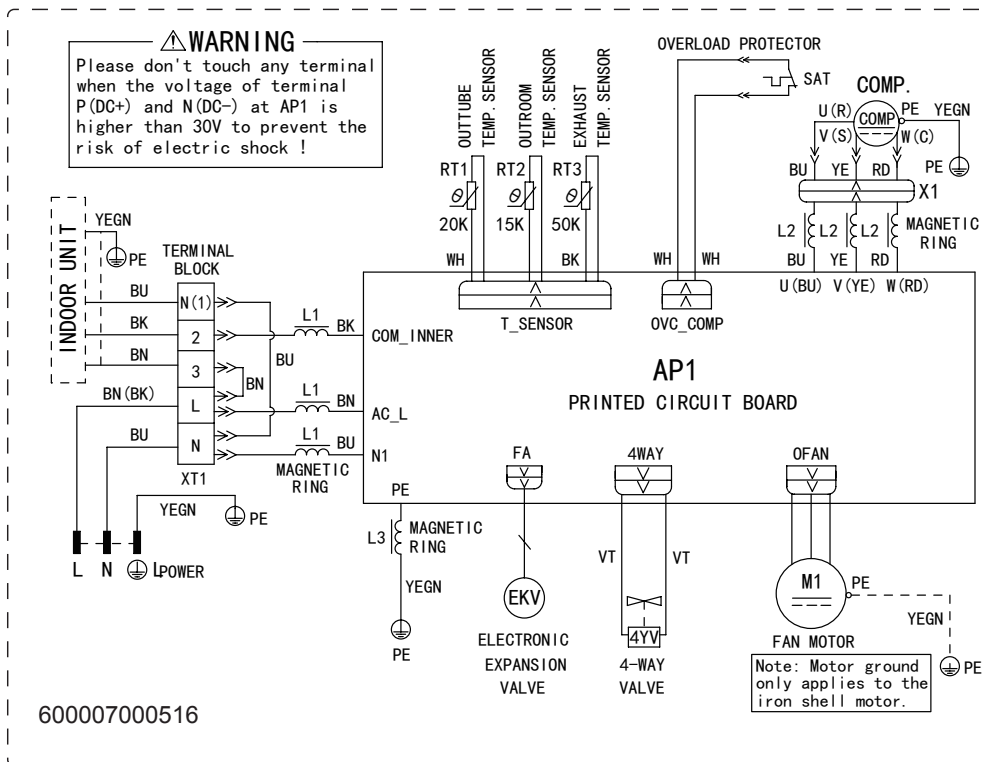

GWH09AGA-K6DNA1A/O(CB385W01000) GWH12AGB-K6DNA1A/O(CB385W01700)

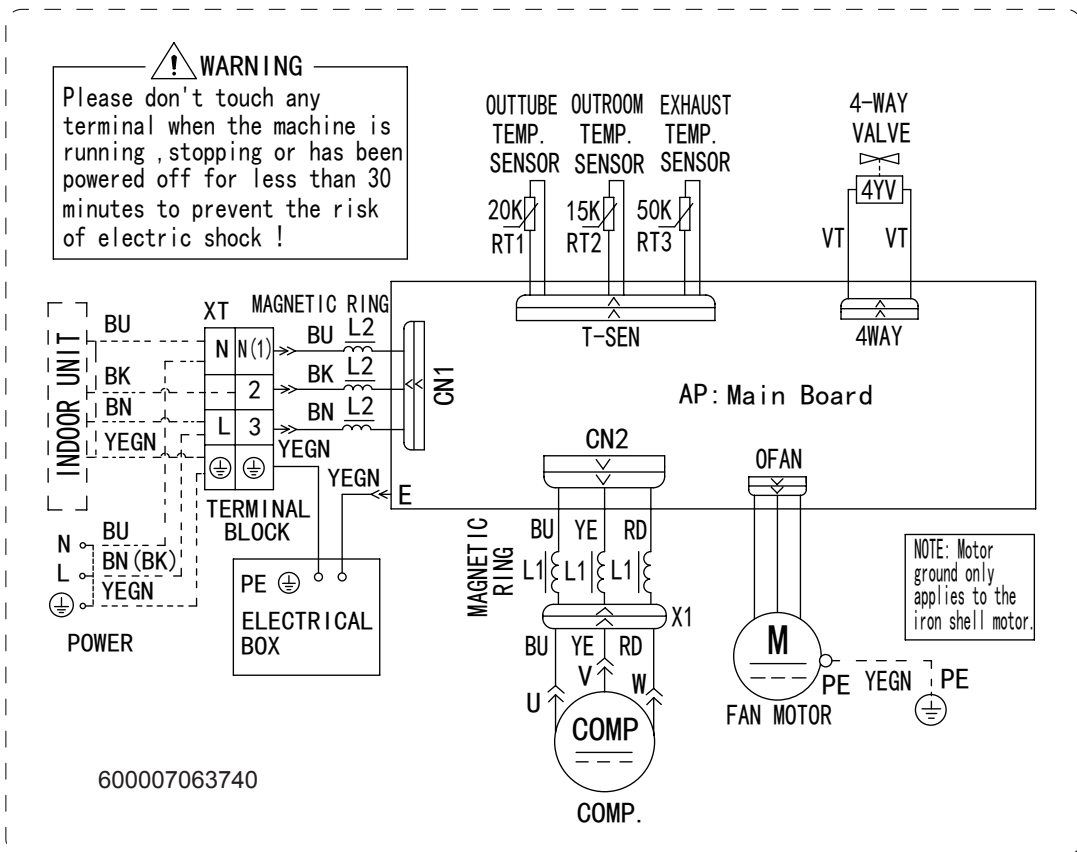

These circuit diagrams are subject to change without notice, please refer to the one supplied with the unit.

5.2 PCB Printed Diagram

Indoor Unit

All models except:GWH09QC-K6DNC2A/I GWH12QC-K6DNC2A/I GWH09QC-K6DND2A/I GWH12QC-K6DND2A/I GWH18QD-K6DND2A/I GWH24QE-K6DND2I/I GWH09QA-K6DNB2A/I GWH12QB-K6DNB2A/I

• Top view

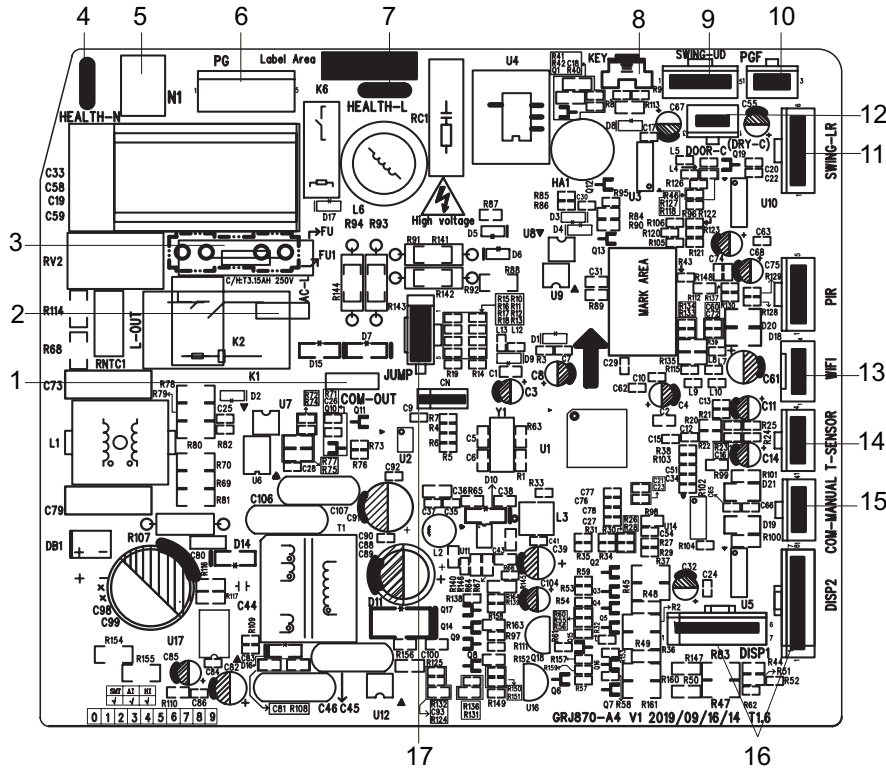

No	Name
1	Interface of communication wire for indoor unit and outdoor unit
2	Interface of live wire
3	Fuse
4	Interface of health function neutral wire(Applicable for some models)
5	Interface of neutral wire
6	Interface of fan
7	Interface of health function live wire (Applicable for some models)
8	Auto button
9	Up&down swing interface
10	Interface of PG feedback
11	Left&right swing interface
12	Interface of dry contact(only for the model with this function)
13	Interface of wifi
14	Needle stand for tube temperature sensor
15	Relay used for controlling wire
16	Display board
17	Jump

• Bottom view

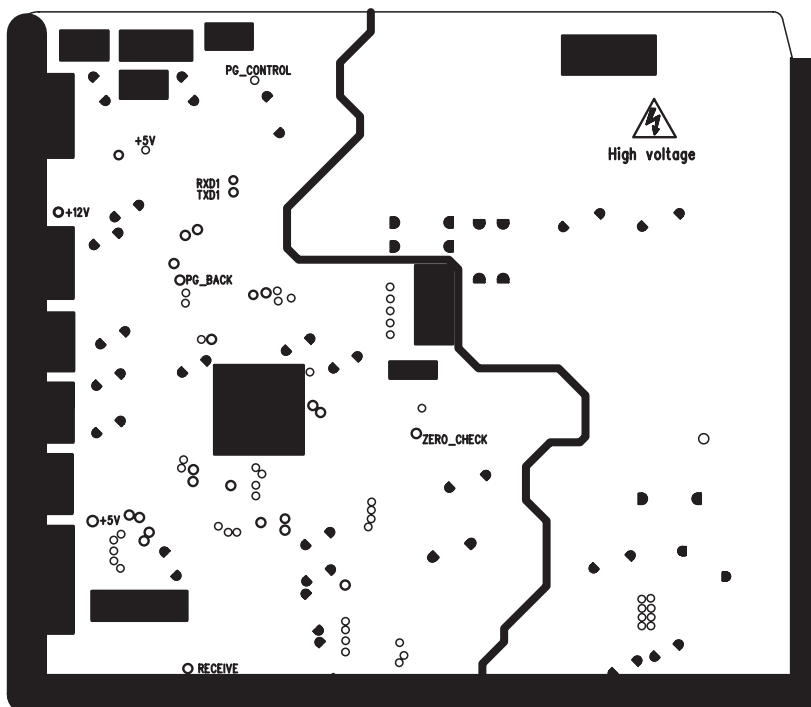

GWH09QA-K6DNB2A/I GWH12QB-K6DNB2A/I

• Top view

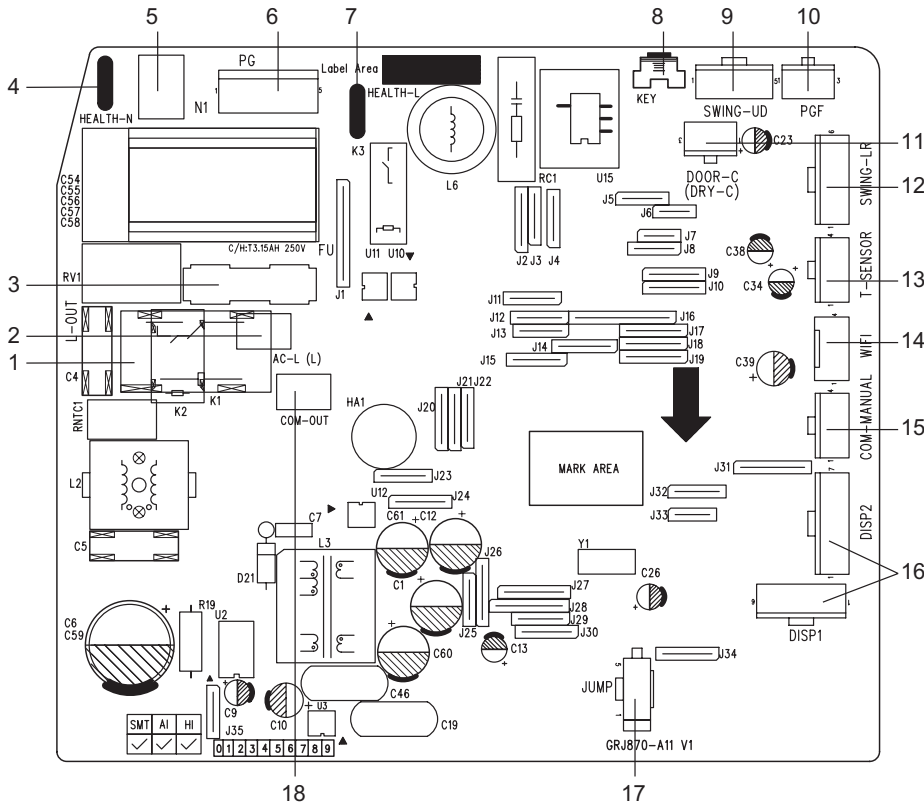

NO.	Name
1	Terminal of live wire used for supplying power for outdoor unit
2	Terminal of live wire
3	Fuse
4	Interface of health function neutral wire
5	Interface of neutral wire
6	Interface of fan
7	Interface of health function live wire
8	Auto button
9	Up&down swing interface
10	Interface of PG feedback
11	Interface of gate-control
12	Terminal of left&right swing
13	Needle stand for tube temperature sensor
14	Interface of wifi
15	Wired controller
16	Display interface
17	Jump
18	Terminal with indoor unit communication wire

• Bottom view

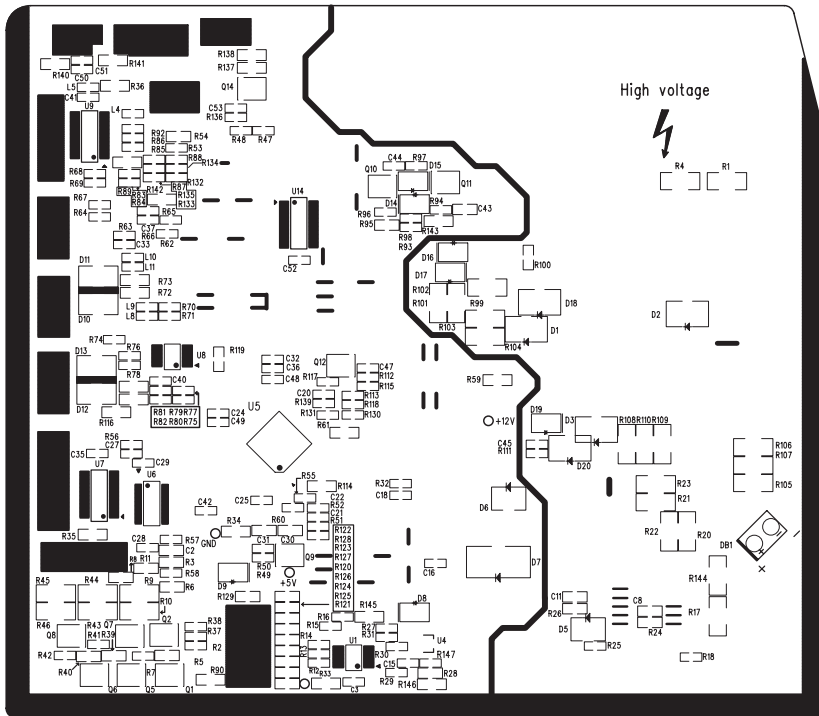

Outdoor Unit

09/12K for some model

• Top view

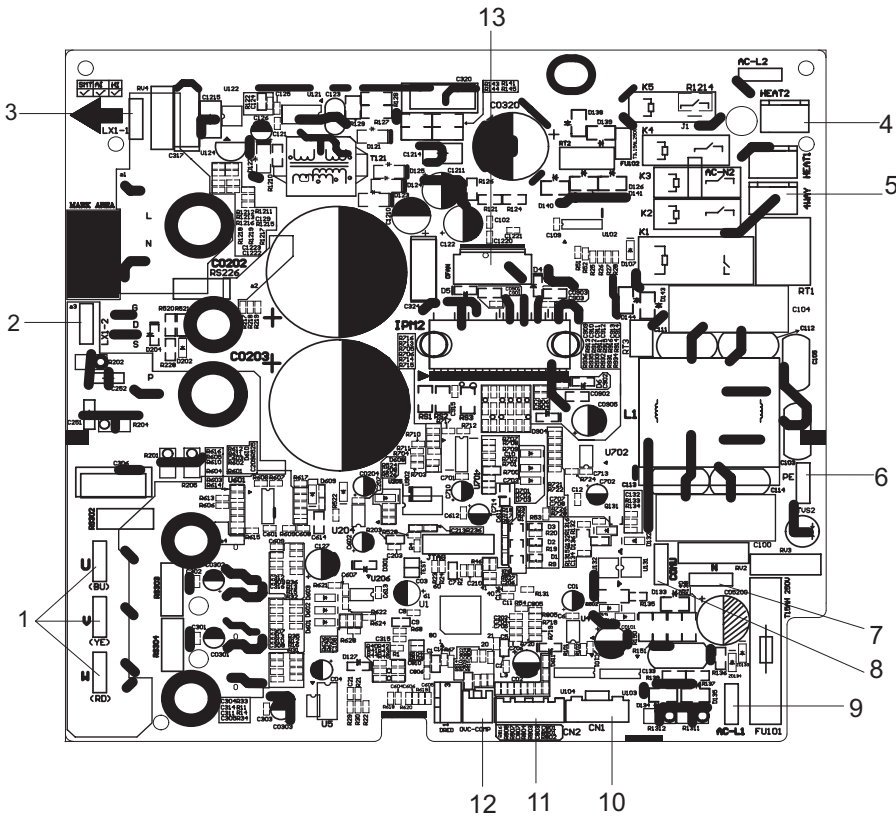

No.	Name
1	Interface of compressor wire
2	Reactor wiring terminal 2
3	Reactor wiring terminal 1
4	Terminal of chassis electric heater
5	4-way valve terminal
6	Grounding wire
7	Neutral wire
8	Communication wire
9	Live wire
10	Terminal of electronic expansion valve
11	Interface of temperature sensor
12	Overload interface of compressor
13	Terminal of outdoor fan

• Bottom view



24K

• Top View

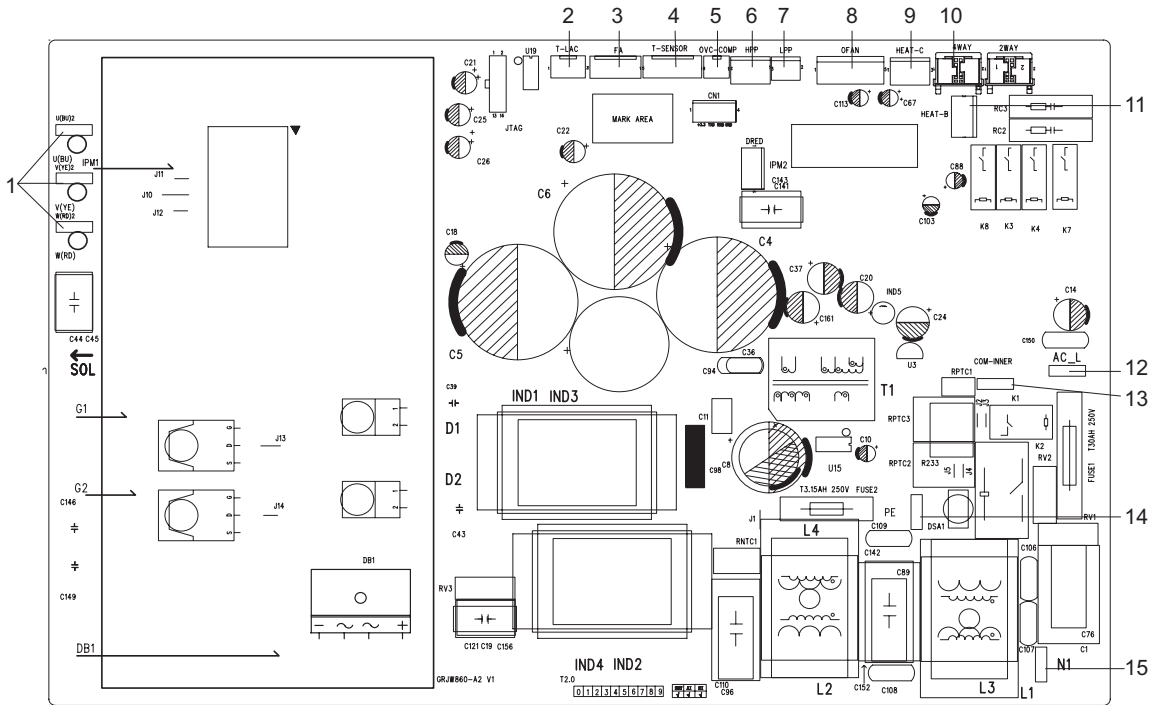

NO.	Name	NO.	Name	NO.	Name
1	Compressor three phase input interface	6	Terminal of high pressure protection	11	Terminal of chassis electric heating
2	Terminal of low ambient temperature cooling temperature sensor	7	Terminal of low pressure protection	12	Terminal of live wire
3	Terminal of electronic expansion valve	8	Terminal of outdoor fan	13	Terminal of communication
4	Terminal of outdoor temperature sensor	9	Terminal of compressor electric heating	14	Terminal of grounding wire
5	Terminal of compressor overload protection	10	Terminal of 4-way valve	15	Terminal of neutral wire

• Bottom View

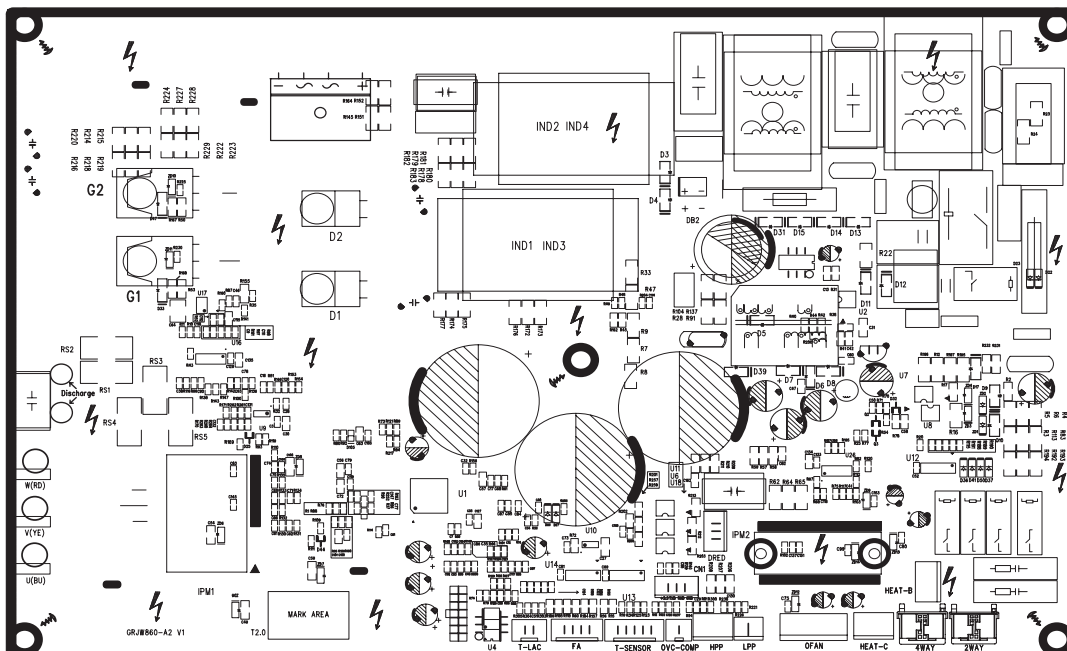

6. Function and Control

6.1 Remote Controller Introduction

Buttons on Remote Controller

YAC1FB9(WiFi)



- 1 ON/OFF button
- 2 MODE button
- 3 FAN button
- 4 TURBO button
- 5 ▲/ ▼ button
- 6 信号 icon button
- 7 健康 icon button
- 8 SLEEP button
- 9 I FEEL button
- 10 TIMER ON / TIMER OFF button
- 11 CLOCK button
- 12 QUIET button
- 13 WiFi button
- 14 LIGHT button
- 15 上/下 icon button
- 16 TEMP button

Introduction for icons on display screen

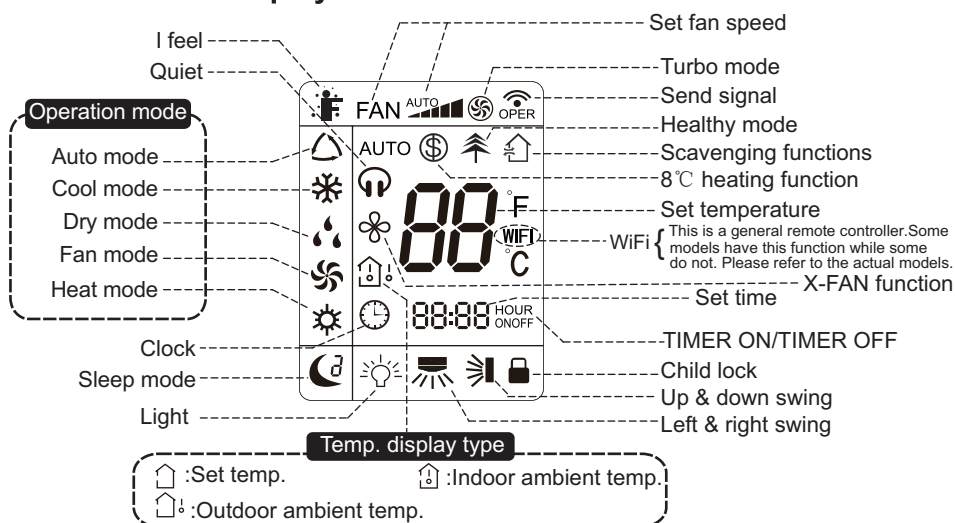

Introduction for buttons on remote controller

Note:

- This is a general use remote controller, it could be used for the air conditioners with multifunction; For some function, which the model doesn't have, if press the corresponding button on the remote controller that the unit will keep the original running status.
- After putting through the power, the air conditioner will give out a sound. Operation indicator "⏻" is ON (red indicator, the colour is different for different models). After that, you can operate the air conditioner by using remote controller.
- Under on status, pressing the button on the remote controller, the signal icon "信号" on the display of remote controller will blink once and the air conditioner will give out a "di" sound, which means the signal has been sent to the air conditioner.
- As for the models with functions of WiFi or wired controller, the indoor unit must have been controlled by standard remote controller under auto mode first, and then the function of adjustable temperature under auto mode can be realized by APP or the wired controller.
- This remote controller can adjust the temperature under auto mode. When matching with the unit which is without the function of adjustable temperature under auto mode, the set temperature under auto mode may be invalid, or the displayed set temperature on the unit is not same as that on the remote controller under auto mode.

1. ON/OFF button

Press this button to turn on the unit. Press this button again to turn off the unit.

2. MODE button

Press this button to select your required operation mode.

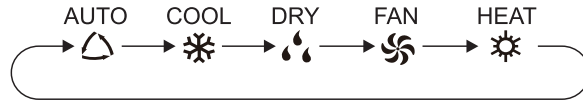

- When selecting auto mode, air conditioner will operate automatically according to ex-factory setting. Press "FAN" button can adjust fan speed. Press " " / " " button can adjust fan blowing angle.
- After selecting cool mode, air conditioner will operate under cool mode. Cool indicator " ❄️ " on indoor unit is ON. (This indicator is not available for some models). Press "▲" or " ▼ " button to adjust set temperature. Press "FAN" button to adjust fan speed. Press " " / " " button to adjust fan blowing angle.
- When selecting dry mode, the air conditioner operates at low speed under dry mode. Dry indicator " 💧 " on indoor unit is ON. (This indicator is not available for some models). Under dry mode, fan speed can't be adjusted. Press " " / " " button to adjust fan blowing angle.
- When selecting fan mode, the air conditioner will only blow fan, no cooling and no heating. All indicators are OFF. Operation indicator is ON. Press "FAN" button to adjust fan speed. Press " " / " " button to adjust fan blowing angle.
- When selecting heating mode, the air conditioner operates under heat mode. Heat indicator " ☀️ " on indoor unit is ON. (This indicator is not available for some models). Press "▲" or " ▼ " button to adjust set temperature. Press "FAN" button to adjust fan speed. Press " " / " " button to adjust fan blowing angle. (Cooling only unit won't receive heating mode signal. If setting heat mode with remote controller, press ON/OFF button can't start up the unit.

Note:

- For preventing cold air, after starting up heating mode, indoor unit will delay 1~5 minutes to blow air (actual delay time is depend on indoor ambient temperature).
- Set temperature range from remote controller: 16~30℃ (61-86°F); Fan speed: auto, low speed, low-medium speed, medium speed, medium-high speed, high speed.
- Under auto mode, temperature can be displayed; Under auto mode, set temperature can be adjusted.

3. FAN button

This button is used for setting Fan Speed in the sequence that goes from AUTO, Low speed, Low-Medium speed, Medium speed, Medium-High speed, High speed, then back to Auto.

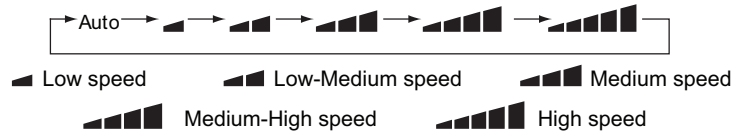

Note:

- It's Low fan speed under Dry mode.
- X-FAN function Hold fan speed button for 2s in COOL or DRY mode, the icon " ⚙️ " is displayed and the indoor fan will continue operation for a few minutes in order to dry the indoor unit even though you have turned off the unit. After energization, X-FAN OFF is defaulted. X-FAN is not available in AUTO, FAN or HEAT mode. This function indicates that moisture on evaporator of indoor unit will be blown after the unit is stopped to avoid mould.
- Having set X-FAN function on: After turning off the unit by pressing ON/OFF button indoor fan will continue running for a few minutes. at low speed. In this period, Hold fan speed button for 2s to stop indoor fan directly.
- Having set X-FAN function off: After turning off the unit by pressing ON/OFF button, the complete unit will be off directly.

4. TURBO button

Under COOL or HEAT mode, press this button to turn to quick COOL or quick HEAT mode. " ⚙️ " icon is displayed on remote controller. Press this button again to exit turbo function and " ⚙️ " icon will disappear. If start this function, the unit will run at super-high fan speed to cool or heat quickly so that the ambient temp. approaches the preset temp. as soon as possible.



5. ▲/▼ button

- Press " ▲ " or " ▼ " button once increase or decrease set temperature 1℃ (°F). Holding " ▲ " or " ▼ " button, 2s later, set temperature on remote controller will change quickly. On releasing button after setting is finished, temperature indicator on indoor unit will change accordingly.
- When setting TIMER ON, TIMER OFF or CLOCK, press " ▲ " or " ▼ " button to adjust time. (Refer to CLOCK, TIMER ON, TIMER OFF buttons)

6. button

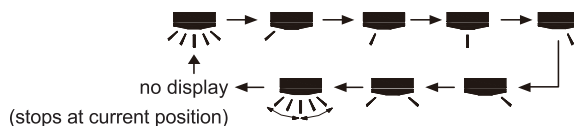
Press this button can select left & right swing angle. Fan blow angle can be selected circularly as below:









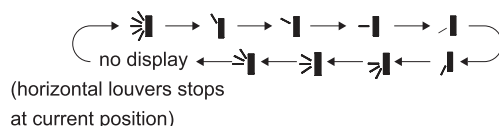



- Note:**
- Press this button continuously more than 2s, the main unit will swing back and forth from left to right, and then loosen the button, the unit will stop swinging and present position of guide louver will be kept immediately.
 - Under swing left and right mode, when the status is switched from off to , if press this button again 2s later,  status will switch to off status directly; if press this button again within 2s, the change of swing status will also depend on the circulation sequence stated above.
 - The  function is only available for some mode





7. button

Press this button can select up & down swing angle. Fan blow angle can be selected circularly as below:







- When selecting "", air conditioner is blowing fan automatically. Horizontal louver will automatically swing up & down at maximum angle.
- When selecting ", , , , ", air conditioner is blowing fan at fixed position. Horizontal louver will stop at the fixed position.
- When selecting ", , ", air conditioner is blowing fan at fixed angle. Horizontal louver will send air at the fixed angle.
- Hold "" button above 2s to set your required swing angle. When reaching your required angle, release the button.



Note:

- ", , " may not be available. When air conditioner receives this signal, the air conditioner will blow fan automatically.
- Press this button continuously more than 2s, the main unit will swing back and forth from up to down, and then loosen the button, the unit will stop swinging and present position of guide louver will be kept immediately.
- Under swing up and down mode, when the status is switched from off to , if press this button again 2s later,  status will switch to off status directly; if press this button again within 2s, the change of swing status will also depend on the circulation sequence stated above.

8. SLEEP button

- Press this button, can select Sleep 1 () , Sleep 2 () , Sleep 3 () and cancel the Sleep, circulate between these, after electrified, Sleep Cancel is defaulted. Sleep 1 is Sleep mode 1, in Cool modes; sleep status after run for one hour, the main unit setting temperature will increase 1 , two hours, setting temperature increased 2 , then the unit will run at this setting temperature; In Heat mode: sleep status after run for one hour, the setting temperature will decrease 1 , two hours, setting temperature will decrease 2 , then the unit will run at this setting temperature.
- Sleep 2 is sleep mode 2, that is air conditioner will run according to the presetting a group of sleep temperature curve.
- Sleep 3-the sleep curve setting under Sleep mode by DIY;
 - (1) Under Sleep 3 mode, press "Turbo" button for a long time, remote controller enters into user individuation sleep setting status, at this time, the time of remote controller will display "1hour", the setting temperature "88" will display the corresponding temperature of last setting sleep curve and blink (The first entering will display according to the initial curve setting value of original factory);
 - (2) Adjust "" and "" button, could change the corresponding setting temperature, after adjusted, press "Turbo" button for confirmation;
 - (3) At this time, 1hour will be automatically increased at the timer position on the remote control, (that are "2hours" or "3hours" or "8hours"), the place of setting temperature "88" will display the corresponding temperature of last setting sleep curve and blink;
 - (4) Repeat the above step (2)~(3) operation, until 8 hours temperature setting finished, sleep, curve setting finished, at this time, the remote controller will resume the original imer display; temperature display will resume to original setting temperature.
- Sleep3- the sleep curve setting under Sleep mode by DIY could be inquired: The user could accord to sleep curve setting method to inquire the presetting sleep curve, enter into user individuation sleep setting status, but do not change the temperature, press "Turbo" button directly for confirmation. Note: In the above presetting or enquiry procedure, if continuously within 10s, there is no button pressed, the sleep curve setting within 10s, there is no button pressed, the sleep curve setting status will be automatically quit and resume to display the original displaying. In the presetting or enquiry procedure, press "ON/OFF" button, "Mode" button, "Timer" button or "Sleep" button, the sleep curve setting or enquiry status will quit similarly.

9. I FEEL button

Press this button to start I FEEL function and "" will be displayed on the remote controller. After this function is set, the remote controller will send the detected ambient temperature to the controller and the unit will automatically adjust the indoor temperature according to the detected temperature. Press this button again to close I FEEL function and "" will disappear.

- Please put the remote controller near user when this function is set. Do not put the remote controller near the object of high temperature or low temperature in order to avoid detecting inaccurate ambient temperature.
- When I FEEL function is turned on, the remote controller should be put within the area where indoor unit can receive the signal sent by the remote controller.

10. TIMER ON / TIMER OFF button

• TIMER ON button

"TIMER ON" button can set the time for timer on. After pressing this button, "🕒" icon disappears and the word "ON" on remote controller blinks. Press "▲" or "▼" button to adjust TIMER ON setting. After each pressing "▲" or "▼" button, TIMER ON setting will increase or decrease 1min. Hold "▲" or "▼" button, 2s later, the time will change quickly until reaching your required time. Press "TIMER ON" to confirm it. The word "ON" will stop blinking. "🕒" icon resumes displaying. Cancel TIMER ON: Under the condition that TIMER ON is started up, press "TIMER ON" button to cancel it.

• TIMER OFF button

"TIMER OFF" button can set the time for timer off. After pressing this button, "🕒" icon disappears and the word "OFF" on remote controller blinks. Press "▲" or "▼" button to adjust TIMER OFF setting. After each pressing "▲" or "▼" button, TIMER OFF setting will increase or decrease 1min. Hold "▲" or "▼" button, 2s later, the time will change quickly until reaching your required time. Press "TIMER OFF" word "OFF" will stop blinking. "🕒" icon resumes displaying. Cancel TIMER OFF. Under the condition that TIMER OFF is started up, press "TIMER OFF" button to cancel it.

Note:

- Under on and off status, you can set TIMER OFF or TIMER ON simultaneously.
- Before setting TIMER ON or TIMER OFF, please adjust the clock time.
- After starting up TIMER ON or TIMER OFF, set the constant circulating valid. After that, air conditioner will be turned on or turned off according to setting time. ON/OFF button has no effect on setting. If you don't need this function, please use remote controller to cancel it.

11. CLOCK button

Press this button to set clock time. "🕒" icon on remote controller will blink. Press "▲" or "▼" button within 5s to set clock time. Each pressing of "▲" or "▼" button, clock time will increase or decrease 1 minute. If hold "▲" or "▼" button, 2s later, time will change quickly. Release this button when reaching your required time. Press "CLOCK" button to confirm the time. "🕒" icon stops blinking.

Note:

- Clock time adopts 24-hour mode.
- The interval between two operation can't exceeds 5s. Otherwise, remote controller will quit setting status. Operation for TIMER ON/TIMER OFF is the same.

12. QUIET button

Press this button, the Quiet status is under the Auto Quiet mode (display "🔇" and "AUTO" signal) and Quiet mode (display "🔇" signal) and Quiet OFF (there is no signal of "🔇" displayed), after powered on, the Quiet OFF is defaulted.

Note:

- The Quiet function can be set up in all modes; Under the Quiet mode, the fan speed is not available.
- The Quiet function is only available for some models.
- When quiet function is selected

Under cooling mode: indoor fan operates at notch 4 speed. 10 minutes later or when indoor ambient temperature $\leq 28^{\circ}\text{C}$, indoor fan will operate at notch 2 speed or quiet mode according to the comparison between indoor ambient temperature and set temperature.

Under heating mode: indoor fan operates at notch 3 speed or quiet mode according to the comparison between indoor ambient temperature and set temperature.

Under dry, fan mode: indoor fan operates at quiet mode.

Under auto mode: the indoor fan operates at the auto quiet mode according to actual cooling, heating or fan mode.

13. WiFi button

Press "WiFi" button to turn on WiFi function, "WiFi" icon will be displayed on the remote controller;

Hold "WiFi" button for 5s to turn off WiFi function and "WiFi" icon will disappear.

Under off status, press "MODE" and "WiFi" buttons simultaneously for 1s, WiFi module will restore factory settings.

- This function is only available for some models.

14. LIGHT button

Press this button to turn off display light on indoor unit. "💡" icon on remote controller disappears. Press this button again to turn on display light. "💡" icon is displayed.

15. 🏠/🏠 button

Press this button to achieve the on and off of healthy and scavenging functions in operation status. Press this button for the first time to start scavenging function; LCD displays "🏠". Press the button for the second time to start healthy and scavenging functions simultaneously; LCD displays "🏠" and "🌿". Press this button for the third time to quit healthy and scavenging functions simultaneously. Press the button for the fourth time to start healthy function; LCD display "🌿". Press this button again to repeat the operation above.

- This function is applicable to partial of models.

16. TEMP button

By pressing this button, you can see indoor set temperature, indoor ambient temperature or outdoor ambient temperature on indoor unit's display. The setting on remote controller is selected circularly as below:

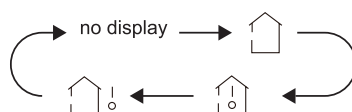

- When selecting " " or no display with remote controller, temperature indicator on indoor unit displays set temperature.
- When selecting " " with remote controller, temperature indicator on indoor unit displays indoor ambient temperature.
- When selecting " " with remote controller, temperature indicator on indoor unit displays outdoor ambient temperature.

Note:

- Outdoor temperature display is not available for some models. At that time, indoor unit receives " " signal, while it displays indoor set temperature.
- It's defaulted to display set temperature when turning on the unit. There is no display in the remote controller.
- Only for the models whose indoor unit has dual-8 display.
- When selecting displaying of indoor or outdoor ambient temperature, indoor temperature indicator displays corresponding temperature and automatically turn to display set temperature after three or five seconds.

Function introduction for combination buttons**1. Energy-saving function**

Under cooling mode, press "TEMP" and "CLOCK" buttons simultaneously to start up or turn off energy-saving function. When energy-saving function is started up, "SE" will be shown on remote controller, and air conditioner will adjust the set temperature automatically according to ex-factory setting to reach to the best energy-saving effect. Press "TEMP" and "CLOCK" buttons simultaneously again to exit energy-saving function.

Note:

- Under energy-saving function, fan speed is defaulted at auto speed and it can't be adjusted.
- Under energy-saving function, set temperature can't be adjusted. Press "TURBO" button and the remote controller won't send signal.
- Sleep function and energy-saving function can't operate at the same time. If energy-saving function has been set under cooling mode, press sleep button will cancel energy-saving function. If sleep function has been set under cooling mode, start up the energy-saving function will cancel sleep function.

2. 8°C heating function

Under heating mode, press "TEMP" and "CLOCK" buttons simultaneously to start up or turn off 8°C heating function. When this function is started up, " " and "8°C" will be shown on remote controller, and the air conditioner keep the heating status at 8°C. Press "TEMP" and "CLOCK" buttons simultaneously again to exit 8°C heating function.

Note:

- Under 8°C heating function, fan speed is defaulted at auto speed and it can't be adjusted.
- Under 8°C heating function, set temperature can't be adjusted. Press "TURBO" button and the remote controller won't send signal.
- Sleep function and 8°C heating function can't operate at the same time. If 8°C heating function has been set under cooling mode, press sleep button will cancel 8°C heating function. If sleep function has been set under cooling mode, start up the 8°C heating function will cancel sleep function.
- Under °F temperature display, the remote controller will display 46 °F heating.

3. Child lock function

Press "▲" and "▼" simultaneously to turn on or turn off child lock function. When child lock function is on, " " icon is displayed on remote controller. If you operate the remote controller, the " " icon will blink three times without sending signal to the unit.

4. Temperature display switchover function

Under OFF status, press "▼" and "MODE" buttons simultaneously to switch temperature display between °C and °F.

If "H1" is displayed on the remote controller while it's not operated by the professional person/after-sales person, it belongs to the misoperation. Please operate it as below to cancel it. Under the OFF status of remote controller, hold the Mode button for 5s to cancel "H1" display.

Note:

- If remote controller displays "H1", it belongs to the normal function reminder. If the unit is defrosting under heating mode, it operates according to H1 defrosting mode. "H1" won't be displayed on the panel of indoor unit;
- Once you set H1 mode, if you turn off unit by remote controller, H1 will display 3 times on the remote controller and then disappear;
- Also, when you set H1 mode, when you change to heating mode, H1 will display 3 times on the remote controller and then disappear.

Replacement of batteries in remote controller

1. Press the back side of remote controller marked with " " , as shown in the fig, and then push out the cover of battery box along the arrow direction.
2. Replace two 7# (AAA 1.5V) dry batteries, and make sure the position of "+" polar and "-" polar are correct.
3. Reinstall the cover of battery box.

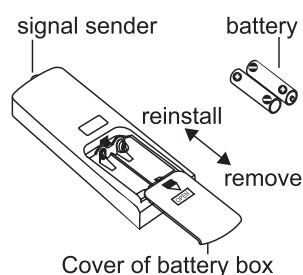

Buttons on Remote Controller

YAG1FB2(WiFi)

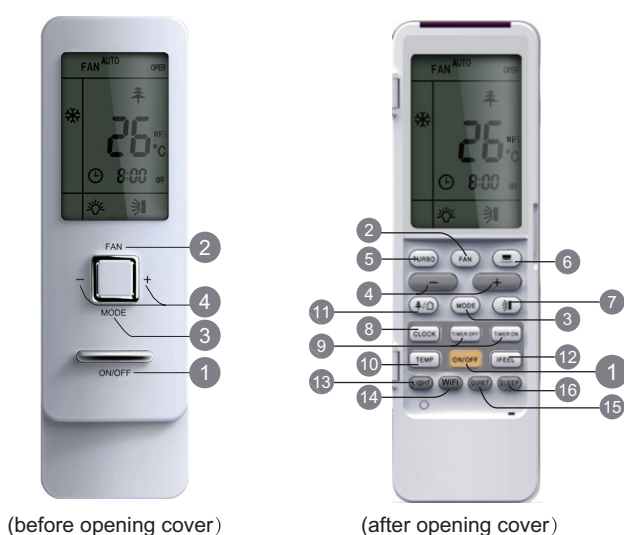

(before opening cover)

(after opening cover)

- 1 ON/OFF button
- 2 FAN button
- 3 MODE button
- 4 +/- button

- 1 ON/OFF button
- 2 FAN button
- 3 MODE button
- 4 +/- button
- 5 TURBO button
- 6 I FEEL button
- 7 SLEEP button
- 8 CLOCK button
- 9 TIMER ON/TIMER OFF button
- 10 TEMP button
- 11 Up/Down arrow button
- 12 I FEEL button
- 13 LIGHT button
- 14 WiFi button
- 15 QUIET button
- 16 SLEEP button

Introduction for Icons on Display Screen

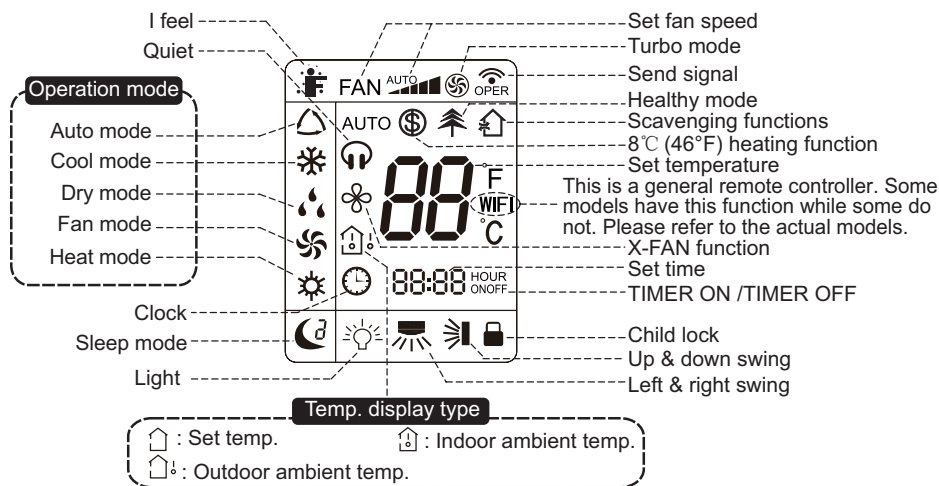

Introduction for Buttons on Remote Controller

Note:

- This is a general use remote controller, it could be used for the air conditioners with multifunction; For some function, which the model don't have, if press the corresponding button on the remote controller that the unit will keep the original running status.
- After putting through the power, the air conditioner will give out a sound. Operation indicator "⏻" is ON (red indicator, the colour is different for different models). After that, you can operate the air conditioner by using remote controller.
- Under on status, pressing the button on the remote controller, the signal icon "📶" on the display of remote controller will blink once and the air conditioner will give out a "de" sound, which means the signal has been sent to the air conditioner.
- Under off status, set temperature and clock icon will be displayed on the display of remote controller (If timer on, timer off and light functions are set, the corresponding icons will be displayed on the display of remote controller at the same time); Under on status, the display will show the corresponding set function icons.

1. ON/OFF button

Press this button to turn on the unit. Press this button again to turn off the unit.

10. TEMP button

Press this button, you can see indoor set temperature, indoor ambient temperature or outdoor ambient temperature on indoor unit's display. The setting on remote controller is selected circularly as below:







When selecting "no display" with remote controller, temperature indicator on indoor unit displays set temperature; When selecting "indoor" with remote controller, temperature indicator on indoor unit displays indoor ambient temperature; When selecting "outdoor" with remote controller, temperature indicator on indoor unit displays outdoor ambient temperature. 3s later it will return to the setting temperature or it depends on the other received signal within 3s.

Attention: When displaying the outdoor ambient, the displaying range is 32-99 °F and 0-60°C, When it goes beyond the range, it keeps the threshold data (the smallest 0 or 32°F and the largest 99°F or 60°C).

Warm tips: When operating buttons on the cover please make sure the cover is closed completely.

NOTE: Outdoor temperature display is not available for some models. At that time, indoor unit receives "indoor" signal, while it displays indoor set temperature.

11. / button (This function is only available for some models)

Press this button to achieve the on and off of healthy and scavenging functions in operation status. Press this button for the first time to start scavenging function; LCD displays "". Press the button for the second time to start healthy and scavenging functions simultaneously; LCD displays "" and "". Press this button for the third time to quit healthy and scavenging functions simultaneously. Press the button for the fourth time to start healthy function; LCD display "". Press this button again to repeat the operation above.

NOTE: This function is applicable to partial of models.

12. I FEEL button

Press this button once, to turn on the I FEEL function, then the figure of "I FEEL" will be displayed, after every press of other function button, every 200ms to send I FEEL once, after this function started, the remote control will send temperature to the main unit in every 10 minutes. When repress this button, this function will be turned off.

13. LIGHT button

Press this button at unit On or Off status, Light On and Light Off can be set up. After powered on, Light On is defaulted.

14. WiFi button





Press "WiFi" button to turn on WiFi function, "WiFi" icon will be displayed on the remote controller;

Hold "WiFi" button for 5s to turn off WiFi function and "WiFi" icon will disappear.



Under off status, press "MODE" and "WiFi" buttons simultaneously for 1s, WiFi module will restore factory settings.

- This function is only available for some models.

15. QUIET button

Press this button, the Quiet status is under the Auto Quiet mode (display "" and "Auto" signal) and Quiet mode (display "" signal) and Quiet OFF (there is no signal of "" displayed), after powered on, the Quiet OFF is defaulted. Under the Quiet mode (Display "" signal), the fan speed is not available.

16. SLEEP button

• Press this button, can select Sleep 1 (), Sleep 2 (), Sleep 3 () and cancel the Sleep, circulate between these, after electrified, Sleep Cancel is defaulted.

• Sleep 1 is Sleep mode 1, in Cool, Dehumidify modes: sleep status after run for one hour, the main unit setting temperature will increase 1°C (1°F or 2°F), 2 hours, setting temperature increased 2°C (3°F or 4°F), the unit will run at this setting temperature; In Heat mode: sleep status after run for one hour the setting temperature will decrease 1°C (1°F or 2°F), 2 hours, setting temperature will decrease 2°C, then the unit will run at this setting temperature.

• Sleep 2 is sleep mode 2, that is air conditioner will run according to the presetting a group of sleep temperature curve.

In Cool mode:

(1) When setting the initial temperature 16~23°C (61°F or 74°F), after turned on Sleep function, the temperature will be increased 1°C (1°F or 2°F) in every hour, after 3°C (5°F or 6°F) the temperature will be maintained, after 7 hours, the temperature will be decreased 1°C,

after that the unit will keep on running under this temperature;

(2) When setting the initial temperature 24~27°C, after turned on Sleep function, the temperature will be increased 1°C in every hour, after 2°C the temperature will be maintained, after 7 hours, the temperature will be decreased 1°C (1°F or 2°F), after that the unit will keep on running under this temperature;

(3) When setting the initial temperature 28~29°C (82°F or 75°F), after turned on Sleep function, the temperature will be increased 1°C (1°F or 2°F) in every hour, after 1°C (1°F or 2°F) the temperature will be maintained, after 7 hours, the temperature will be decreased 1°C (1°F or 2°F), after that the unit will keep on running under this temperature;

(4) When setting the initial temperature 30°C (86°F), under this temperature setting, after 7 hours, the temperature will be decreased 1°C (1°F or 2°F), after that the unit will keep on running under this temperature;

In Heat mode:

(1) Under the initial presetting temperature 16°C (61°F), it will run under this setting temperature all along.

(2) Under the initial presetting temperature 17~20°C (62°F or 68°F), after Sleep function started up, the temperature will decrease 1°C (1°F or 2°F) in every hour, after 1°C (1°F or 2°F) decreased, this temperature will be maintained.

(3) Under the initial presetting temperature 21~27°C (69°F or 81°F), after Sleep function started up, the temperature will decrease 1°C (1°F or 2°F) in every hour, after 2°C (3°F or 4°F) decreased, this temperature will be maintained.

(4) Under the initial presetting temperature 28~30°C (82°F or 86°F), after Sleep function started up, the temperature will decrease 1°C 3°C (5°F or 6°F) decreased, this temperature will be maintained

●Sleep 3- the sleep curve setting under Sleep mode by DIY:

- (1) Under Sleep 3 mode, press "Turbo" button for a long time, remote control enters into user individuation sleep setting status, at this time, the time of remote control will display "1hour ", the setting temperature "88" will display the corresponding temperature of last setting sleep curve and blink (The first entering will display according to the initial curve setting value of original factory);
- (2) Adjust "+" and "-" button, could change the corresponding setting temperature, after adjusted, press "Turbo" button for confirmation;
- (3) At this time, 1hour will be automatically increased at the timer position on the remote control, (that are "2hours" or "3hours" or "8hours "), the place of setting temperature "88" will display the corresponding temperature of last setting sleep curve and blink;
- (4) Repeat the above step (2)(3) operation, until 8hours temperature setting finished, sleep curve setting finished, at this time, the remote control will resume the original timer display;temperature display will resume to original setting temperature.

●Sleep3- the sleep curve setting under Sleep mode by DIY could be inquired:

The user could accord to sleep curve setting method to inquire the presetting sleep curve, enter into user individuation sleep setting status, but do not change the temperature, press "Turbo" button directly for confirmation.

Note: In the above presetting or enquiry procedure, if continuously within 10s, there is no button pressed, the sleep curve setting status will be automatically quit and resume to display the original displaying. In the presetting or enquiry procedure, press "ON/OFF" button, "Mode" button, "Timer" button or "Sleep" button, the sleep curve setting or enquiry status will quit similarly.

17. About AUTO RUN

When AUTO RUN mode is selected, the unit will be in accordance with the room temp. automatically to select the suitable running method and to make ambient comfortable.

18. About turbo function



If start this function, the unit will run at super-high fan speed to cool or heat quickly so that the ambient temp. approaches the preset temp. as soon as possible.

19. About lock



Press + and - buttons simultaneously to lock or unlock the keyboard. If the remote controller is locked, the icon  will be displayed on it, in which case, press any button, the mark will flicker for three times.

If the keyboard is unlocked, the mark will disappear.

20. About swing up and down

1. Press swing up and down button continuously more than 2s, the main unit will swing back and forth from up to down, and then loosen the button, the unit will stop swing and present position of guide louver will be kept immediately.
2. Under swing up and down mode, when the status is switched from off to , if press this button again 2s later,  status will switch to off status directly; If press this button again within 2s, the change of swing status will also depend on the circulation sequence stated above.

21. About swing left and right(This function is only available for some models)

- (1) Press swing left and right button continuously more than 2s, the main unit will swing back and forth from left to right, and then loosen the button, the unit will stop swinging and present position of guide louver will be kept immediately.
- (2) Under swing left and right mode, when the status is switched from off to , if press this button again 2s later,  status will switch to off status directly; if press this button again within 2s, the change of swing status will also depend on the circulation sequence stated above.

22. About switch between Fahrenheit and Centigrade

Under status of unit off, press MODE and - buttons simultaneously to switch °C and °F.

23. Combination of "TEMP" and "CLOCK" buttons : About Energy-saving Function

Press "TEMP" and "CLOCK" simultaneously in COOL mode to start energy-saving function. Nixie tube on the remote controller displays "SE". Repeat the operation to quit the function.

24. Combination of "TEMP" and "CLOCK" buttons : About 8°C(46°F) Heating Function(This function is only available for some models)

Press "TEMP" and "CLOCK" simultaneously in HEAT mode to start 8°C(46°F) Heating Function. Nixie tube on the remote controller displays "8" and a selected temperature of "8°C" (46°F if Fahrenheit is adopted). Repeat the operation to quit the function.

25. About Quiet function

When quiet function is selected:

- (1) Under cooling mode: indoor fan operates at notch 4 speed. 10 minutes later or when indoor ambient temperature ≤ 28°C(82°F), indoor fan will operate at notch 2 speed or quiet mode according to the comparison between indoor ambient temperature and set temperature.
- (2) Under heating mode: indoor fan operates at notch 3 speed or quiet mode according to the comparison between indoor ambient temperature and set temperature.
- (3) Under dry, fan mode: indoor fan operates at quiet mode.
- (4) Under auto mode: the indoor fan operates at the auto quiet mode according to actual cooling, heating or fan mode.

26. About Sleep function

Under the Fan and Auto mode, the Sleep function cannot be set up, under Dehumidify mode, only Sleep 1 can be selected. Select and enter into any kind of Sleep mode, the Quiet function will be attached and started, different Quiet status could be optional and turned off.



If "H1" is displayed on the remote controller while it's not operated by the professional person/after-sales person, it belongs to the misoperation. Please operate it as below to cancel it. Under the OFF status of remote controller, hold the Mode button for 5s to cancel "H1" display.

Note:

- If remote controller displays "H1", it belongs to the normal function reminder. If the unit is defrosting under heating mode, it operates according to H1 defrosting mode. "H1" won't be displayed on the panel of indoor unit;
- Once you set H1 mode, if you turn off unit by remote controller, H1 will display 3 times on the remote controller and then disappear;
- Also, when you set H1 mode, when you change to heating mode, H1 will display 3 times on the remote controller and then disappear.

Operation Guide

1. General operation

- (1) After powered on, press ON/OFF button, the unit will start to run. (Note: When it is powered on, the guide louver of main unit will close automatically.)
- (2) Press MODE button, select desired running mode.
- (3) Pressing + or - button, to set the desired temperature (It is unnecessary to set the temp. at AUTO mode.)
- (4) Pressing FAN button, set fan speed, can select AUTO FAN, LOW, MEDIUM-LOW, MEDIUM, MEDIUM-HIGH and HIGH.
- (5) Pressing  and  button, to select the swing.

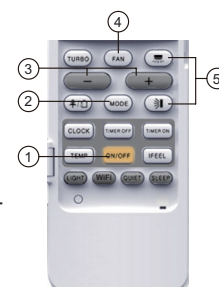

2. Optional operation

- (1) Press SLEEP button, to set sleep.
- (2) Press TIMER ON and TIMER OFF button, can set the scheduled timer on or timer off.
- (3) Press LIGHT button, to control the on and off of the displaying part of the unit (This function may be not available for some units).
- (4) Press TURBO button, can realize the ON and OFF of TURBO function.

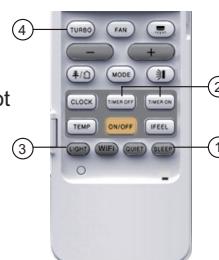

Replacement of Batteries in Remote Controller

1. Press the back side of remote controller marked with , as shown in the fig., and then push out the cover of battery box along the arrow direction.
2. Replace two 7# (AAA 1.5V) dry batteries, and make sure the position of "+" polar and "-" polar are correct.
3. Reinstall the cover of battery box.

Note:

- During operation, point the remote control signal sender at the receiving window on indoor unit.
- The distance between signal sender and receiving window should be no more than 8m, and there should be no obstacles between them.
- Signal may be interfered easily in the room where there is fluorescent lamp or wireless telephone; remote controller should be close to indoor unit during operation.
- Replace new batteries of the same model when replacement is required.
- When you don't use remote controller for a long time, please take out the batteries.
- If the display on remote controller is fuzzy or there's no display, please replace batteries.

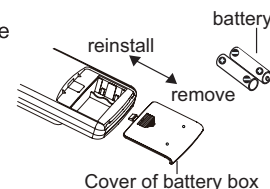

1. ON/OFF button

Press this button to turn on the unit. Press this button again to turn off the unit.

2. MODE button

Press this button to select your required operation mode.



- When selecting auto mode, air conditioner will operate automatically according to the sensed temperature. Set temperature can't be adjusted and will not be displayed as well. Press "FAN" button can adjust fan speed. Press " " / " " button can adjust fan blowing angle.
- After selecting cool mode, air conditioner will operate under cool mode. Cool indicator " " on indoor unit is ON. (This indicator is not available for some models) Press "▲" or "▼" button to adjust set temperature. Press "FAN" button to adjust fan speed. Press " " / " " button to adjust fan blowing angle.
- When selecting dry mode, the air conditioner operates at low speed under dry mode. Dry indicator " " on indoor unit is ON. (This indicator is not available for some models) Under dry mode, fan speed can't be adjusted. Press " " / " " button to adjust fan blowing angle.
- When selecting fan mode, the air conditioner will only blow fan, no cooling and no heating. All indicators are OFF, Operation indicator is ON. Press "FAN" button to adjust fan speed. Press " " / " " button to adjust fan blowing angle.
- When selecting heating mode, the air conditioner operates under heat mode. Heat indicator " " on indoor unit is ON. (This indicator is not available for some models) Press "▲" or "▼" button to adjust set temperature. Press "FAN" button to adjust fan speed. Press " " / " " button to adjust fan blowing angle. (Cooling only unit won't receive heating mode signal. If setting heat mode with remote controller, press ON/OFF button can't start up the unit).

Note:

- For preventing cold air, after starting up heating mode, indoor unit will delay 1~5 minutes to blow air (actual delay time is depend on indoor ambient temperature).
- Set temperature range from remote controller: 16~30°C ; Fan speed: auto, low speed, medium speed, high speed.

3. FAN button

Pressing this button can set fan speed circularly as: auto (AUTO), low(), medium(), high().



Note:

- Under AUTO speed, air conditioner will select proper fan speed automatically according to ex-factory setting.
- It's Low fan speed under Dry mode.
- X-FAN function Hold fan speed button for 2s in COOL or DRY mode, the icon " " is displayed and the indoor fan will continue operation for a few minutes in order to dry the indoor unit even though you have turned off the unit. After energization, X-FAN OFF is defaulted. X-FAN is not available in AUTO, FAN or HEAT mode. This function indicates that moisture on evaporator of indoor unit will be blowed after the unit is stopped to avoid mould.
- Having set X-FAN function on: After turning off the unit by pressing ON/OFF button indoor fan will continue running for a few minutes. at low speed. In this period, Hold fan speed button for 2s to stop indoor fan directly.
- Having set X-FAN function off: After turning off the unit by pressing ON/OFF button, the complete unit will be off directly.

4. TURBO button

- Under COOL or HEAT mode, press this button to turn to quick COOL or quick HEAT mode. " " icon is displayed on remote controller. Press this button again to exit turbo function and " " icon will disappear. If start this function, the unit will run at super-high fan speed to cool or heat quickly so that the ambient temp. approaches the preset temp. as soon as possible.

5. ▲/▼ button



- Press "▲" or "▼" button once increase or decrease set temperature 1°C . Holding "▲" or "▼" button, 2s later, set temperature on remote controller will change quickly. On releasing button after setting is finished, temperature indicator on indoor unit will change accordingly. (Temperature can't be adjusted under auto mode)
- When setting T-ON, T-OFF or CLOCK, press "▲" or "▼" button to adjust time. (Refer to CLOCK, T-ON, T-OFF buttons)

6.  button

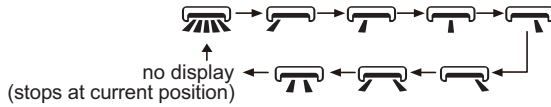
Press this button can select left & right swing angle. Fan blow angle can be selected circularly as below:











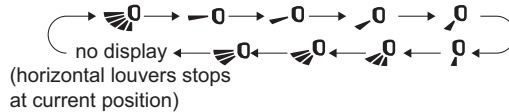



Note:

- Press this button continuously more than 2s, the main unit will swing back and forth from left to right, and then loosen the button, the unit will stop swinging and present position of guide louver will be kept immediately.
- Under swing left and right mode, when the status is switched from off to , if press this button again 2s later,  status will switch to off status directly; if press this button again within 2s, the change of swing status will also depend on the circulation sequence stated above.





7.  button

Press this button can select up & down swing angle. Fan blow angle can be selected circularly as below:











- When selecting "", air conditioner is blowing fan automatically. Horizontal louver will automatically swing up & down at maximum angle.
- When selecting ", , , , , ", air conditioner is blowing fan at fixed position. Horizontal louver will stop at the fixed position.
- When selecting ", , ", air conditioner is blowing fan at fixed angle. Horizontal louver will send air at the fixed angle.
- Hold "" button above 2s to set your required swing angle. When reaching your required angle, release the button.

Note:

- ", , " may not be available. When air conditioner receives this signal, the air conditioner will blow fan automatically.
- Press this button continuously more than 2s, the main unit will swing back and forth from up to down, and then loosen the button, the unit will stop swinging and present position of guide louver will be kept immediately.
- Under swing up and down mode, when the status is switched from off to , if press this button again 2s later,  status will switch to off status directly; if press this button again within 2s, the change of swing status will also depend on the circulation sequence stated above.

8. T-ON / T-OFF button



- T-ON button

"T-ON" button can set the time for timer on. After pressing this button, "" icon disappears and the word "ON" on remote controller blinks. Press "" or "" button to adjust T-ON setting. After each pressing "" or "" button, T-ON setting will increase or decrease 1min. Hold "" or "" button, 2s later, the time will change quickly until reaching your required time. Press "T-ON" to confirm it. The word "ON" will stop blinking. "" icon resumes displaying. Cancel T-ON: Under the condition that T-ON is started up, press "T-ON" button to cancel it.

Note:









- Under on and off status, you can set T-OFF or T-ON simultaneously.
- Before setting T-ON or T-OFF, please adjust the clock time.
- After starting up T-ON or T-OFF, set the constant circulating valid. After that, air conditioner will be turned on or turned off according to setting time. ON/OFF button has no effect on setting. If you don't need this function, please use remote controller to cancel it.

9. I FEEL button

Press this button to start I FEEL function and "" will be displayed on the remote controller. After this function is set, the remote controller will send the detected ambient temperature to the controller and the unit will automatically adjust the indoor temperature according to the detected temperature. Press this button again to close I FEEL function and "" will disappear.

- Please put the remote controller near user when this function is set. Do not put the remote controller near the object of high temperature or low temperature in order to avoid detecting inaccurate ambient temperature.
- When I FEEL function is turned on, the remote controller should be put within the area where indoor unit can receive the signal sent by the remote controller.

10. CLOCK button

Press this button to set clock time. "" icon on remote controller will blink. Press "" or "" button within 5s to set clock time. Each pressing of "" or "" button, clock time will increase or decrease 1 minute. If hold "" or "" button, 2s later, time will change quickly. Release this button when reaching your required time. Press "CLOCK" button to confirm the time. "" icon stops blinking.

Note:

- Clock time adopts 24-hour mode.
- The interval between two operation can't exceeds 5s. Otherwise, remote controller will quit setting status. Operation for TIMER ON/TIMER OFF is the same.

11. SLEEP button

Under COOL, or HEAT mode, press this button to start up sleep function.

"☾" icon is displayed on remote controller. Press this button again to cancel sleep function and "☾" icon will disappear.

After powered on, Sleep Off is defaulted. After the unit is turned off, the Sleep function is canceled.

In this mode, the time of time can be adjusted. Under Fan DRY and Auto modes, this function is not available.

12. WiFi button

Press "WiFi" button to turn on WiFi function, "WiFi" icon will be displayed on the remote controller;

Hold "WiFi" button for 5s to turn off WiFi function and "WiFi" icon will disappear.

Under off status, press "MODE" and "WiFi" buttons simultaneously for 1s, WiFi module will restore factory settings.

This function is only available for some models.

13. 🌿/🏠 button

Press this button to achieve the on and off of healthy and scavenging functions in operation status. Press this button for the first time to start scavenging function; LCD displays "🏠". Press the button for the second time to start healthy and scavenging functions simultaneously;

LCD displays "🏠" and "🌿". Press this button for the third time to quit healthy and scavenging functions simultaneously. Press the button for the fourth time to start healthy function; LCD display "🌿". Press this button again to repeat the operation above.

Press this button for the fourth time to start healthy function; LCD display "🌿". Press this button again to repeat the operation above.

- This function is applicable to partial of models.

14. LIGHT button

Press this button to turn off display light on indoor unit. "💡" icon on remote controller disappears. Press this button again to turn on display light. "💡" icon is displayed.

15. TEMP button

By pressing this button, you can see indoor set temperature, indoor ambient temperature or outdoor ambient temperature on indoor unit's display. The setting on remote controller is selected circularly as below:

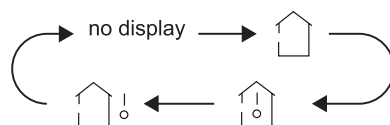

- When selecting "🏠" or no display with remote controller, temperature indicator on indoor unit displays set temperature.
- When selecting "🏠" with remote controller, temperature indicator on indoor unit displays indoor ambient temperature.
- When selecting "🏠" with remote controller, temperature indicator on indoor unit displays outdoor ambient temperature.

Note:

- Outdoor temperature display is not available for some models. At that time, indoor unit receives "🏠" signal, while it displays indoor set temperature.
- It's defaulted to display set temperature when turning on the unit. There is no display in the remote controller.
- Only for the models whose indoor unit has dual-8 display.
- When selecting displaying of indoor or outdoor ambient temperature, indoor temperature indicator displays corresponding temperature and automatically turn to display set temperature after three or five seconds.

Function introduction for combination buttons

1. Energy-saving function

Under cooling mode, press "TEMP" and "CLOCK" buttons simultaneously to start up or turn off energy-saving function. When energy-saving function is started up, "SE" will be shown on remote controller, and air conditioner will adjust the set temperature automatically according to ex-factory setting to reach to the best energy-saving effect. Press "TEMP" and "CLOCK" buttons simultaneously again to exit energy-saving function.

Note:

- Under energy-saving function, fan speed is defaulted at auto speed and it can't be adjusted.
- Under energy-saving function, set temperature can't be adjusted. Press "TURBO" button and the remote controller won't send signal.
- Sleep function and energy-saving function can't operate at the same time. If energy-saving function has been set under cooling mode, press sleep button will cancel energy-saving function. If sleep function has been set under cooling mode, start up the energy-saving function will cancel sleep function.

2. 8°C heating function

Under heating mode, press "TEMP" and "CLOCK" buttons simultaneously to start up or turn off 8°C heating function. When this function is started up, "8°C" and "8°C" will be shown on remote controller, and the air conditioner keep the heating status at 8°C. Press "TEMP" and "CLOCK" buttons simultaneously again to exit 8°C heating function.

Note:

- Under 8°C heating function, fan speed is defaulted at auto speed and it can't be adjusted.
- Under 8°C heating function, set temperature can't be adjusted. Press "TURBO" button and the remote controller won't send signal.
- Sleep function and 8°C heating function can't operate at the same time. If 8°C heating function has been set under cooling mode, press sleep button will cancel 8°C heating function. If sleep function has been set under cooling mode, start up the 8°C heating function will cancel sleep function.
- Under °F temperature display, the remote controller will display 46 °F heating.

3. Child lock function

Press "▲" and "▼" simultaneously to turn on or turn off child lock function. When child lock function is on, "🔒" icon is displayed on remote controller. If you operate the remote controller, the "🔒" icon will blink three times without sending signal to the unit.

4. Temperature display switchover function

Under OFF status, press "▼" and "MODE" buttons simultaneously to switch temperature display between °C and °F .

If "H1" is displayed on the remote controller while it's not operated by the professional person/after-sales person, it belongs to the misoperation.

Please operate it as below to cancel it. Under the OFF status of remote controller, hold the Mode button for 5s to cancel "H1" display.

Note:

- If remote controller displays "H1", it belongs to the normal function reminder. If the unit is defrosting under heating mode, it operates according to H1 defrosting mode. "H1" won't be displayed on the panel of indoor unit;
- Once you set H1 mode, if you turn off unit by remote controller, H1 will display 3 times on the remote controller and then disappear;
- Also, when you set H1 mode, when you change to heating mode, H1 will display 3 times on the remote controller and then disappear.

Replacement of batteries in remote controller

1. Lift the cover along the direction of arrow (as shown in Fig 1 ①).
2. Take out the original batteries (as shown in Fig 1 ②).
3. Place two 7# (AAA 1.5V) dry batteries, and make sure the position of "+" polar and "-" polar is correct (as shown in Fig 2 ③).
4. Reinstall the cover (as shown in Fig 2 ④).

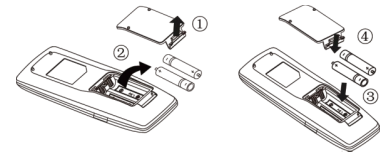

Fig.1

Fig.2

Note:

- During operation, point the remote control signal sender at the receiving window on indoor unit.
- The distance between signal sender and receiving window should be no more than 8m, and there should be no obstacles between them.
- Signal may be interfered easily in the room where there is fluorescent lamp or wireless telephone; remote controller should be close to indoor unit during operation.
- Replace new batteries of the same model when replacement is required.
- When you don't use remote controller for a long time, please take out the batteries.
- If the display on remote controller is fuzzy or there's no display, please replace batteries.

YAN1F6(WiFi)

Buttons on remote controller



Introduction for icons on display screen

	I feel	
FAN AUTO	Set fan speed	
	Turbo mode	
	Send signal	
Operation mode		Auto mode
		Cool mode
		Dry mode
		Fan mode
		Heat mode
	Sleep mode	
	8°C heating function	
	Health mode	
	Scavenging function	
	X-FAN function	
Temp. display type		Set temp.
		Indoor ambient temp.
		Outdoor ambient temp.
	Clock	
88	Set temperature	
WiFi	WiFi function	
88:88	Set time	
ON/OFF	TIMER ON / TIMER OFF	
	Light	
	Up & down swing	
	Child lock	

Introduction for buttons on remote controller

Notice :

- This is a general use remote controller. It could be used for the air conditioner with multifunction. For the functions which the model doesn't have, if press the corresponding button on the remote controller, the unit will keep the original running status.
- After putting through the power, the air conditioner will give out a sound. Power indicator "⏻" is ON. After that, you can operate the air conditioner by using remote controller.
- Under on status, pressing the button on the remote controller, the signal icon "📶" on the display of remote controller will blink once and the air conditioner will give out a "di" sound, which means the signal has been sent to the air conditioner.
- Under off status, set temperature and clock icon will be displayed on the display of remote controller (If timer on, timer off and light functions are set, the corresponding icons will be displayed on the display of remote controller at the same time); Under on status, the display will show the corresponding set function icons.

button

Press this button to turn on the unit. Press this button again to turn off the unit.

button

Press this button to select your required operation mode.

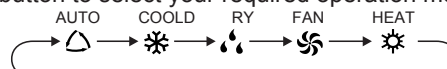



- When selecting auto mode, air conditioner will operate automatically according to ex-factory setting. Set temperature can't be adjusted and will not be displayed as well. Press "FAN" button can adjust fan speed. Press "SWING" button can adjust fan blowing angle.
- After selecting cool mode, air conditioner will operate under cool mode. Press "▲" or "▼" button to adjust set temperature. Press "FAN" button to adjust fan speed. Press "SWING" button to adjust fan blowing angle.
- When selecting dry mode, the air conditioner operates at low speed under dry mode. Under dry mode, fan speed can't be adjusted. Press "SWING" button to adjust fan blowing angle.
- When selecting fan mode, the air conditioner will only blow fan, no cooling and no heating. Press "FAN" button to adjust fan speed. Press "SWING" button to adjust fan blowing angle.
- When selecting heat mode, the air conditioner operates under heat mode. Press "▲" or "▼" button to adjust set temperature.

Notice :

- For preventing cold air, after starting up heat mode, indoor unit will delay 1~5 minutes to blow air (Actual delay time depends on indoor ambient temperature).
- Set temperature range from remote controller: 16~30°C(61-86°F); Fan speed: auto, low speed, medium speed, high speed.
- Cooling only unit won't receive heat mode signal. If setting heat mode with remote controller, press "⏻" button can't start up the unit.

FAN button

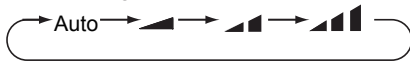

Pressing this button can set fan speed circularly as: auto(AUTO), low() , medium() , high() .



Notice :

- Under AUTO speed, air conditioner will select proper fan speed automatically according to factory default setting.
- It's low fan speed under dry mode.
- X-FAN function: Holding fan speed button for 2s in cool or dry mode, the icon "  " is displayed and the indoor fan will continue operation for a few minutes in order to dry the indoor unit even though you have turned off the unit. After energization, X-FAN OFF is defaulted. X-FAN is not available in auto, fan or heat mode.







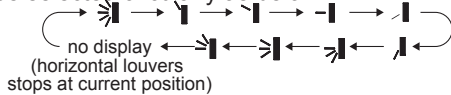

This function indicates that moisture on evaporator of indoor unit will be blown after the unit is stopped to avoid mould.

- Having set X-FAN function on: After turning off the unit by pressing "  " button, indoor fan will continue running for a few minutes at low speed. In this period, hold fan speed button for 2s to stop indoor fan directly.
- Having set X-FAN function off: After turning off the unit by pressing "  " button, the complete unit will be off directly.



SWING button

Press this button can select up & down swing angle. Fan blow angle can be selected circularly as below:





- When selecting "  ", air conditioner is blowing fan automatically. Horizontal louver will automatically swing up & down at maximum angle.
- When selecting "  ,  ,  ", air conditioner is blowing fan at fixed position. Horizontal louver will stop at the fixed position.
- When selecting "  ,  ,  ", air conditioner is blowing fan at fixed angle. Horizontal louver will send air at the fixed angle.
- Hold "  " button above 2s to set your required swing angle. When reaching your required angle, release the button.

Notice :

- "  ,  ,  " may not be available. When air conditioner receives this signal, the air conditioner will blow fan automatically.

TURBO button

Under cool or heat mode, press this button to turn to quick cool or quick heat mode. "  " icon is displayed on remote controller. Press this button again to exit turbo function and "  " icon will disappear.



▲ / ▼ button

Press "▲" or "▼" button once increase or decrease set temperature 1°C(1°F). Holding "▲" or "▼" button, 2s later, set temperature on remote controller will change quickly. On

releasing button after setting is finished, temperature indicator on indoor unit will change accordingly. (Temperature can't be adjusted under auto mode)

When setting TIMER ON, TIMER OFF or CLOCK, press "▲" or "▼" button to adjust time. (Refer to CLOCK, TIMER ON, TIMER OFF buttons)



SLEEP button

Under cool or heat mode, press this button to start up sleep function. "  " icon is displayed on remote controller. Press this button again to cancel sleep function and "  " icon will disappear.

TEMP button

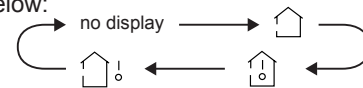
By pressing this button, you can see indoor set temperature, indoor ambient temperature or outdoor ambient temperature on indoor unit's display. The setting on remote controller is selected circularly as below:



- When selecting "  " or no display with remote controller, temperature indicator on indoor unit displays set temperature.
- When selecting "  " with remote controller, temperature indicator on indoor unit displays indoor ambient temperature.
- When selecting "  " with remote controller, temperature indicator on indoor unit displays outdoor ambient temperature.

Notice :

- Outdoor temperature display is not available for some models. At that time, indoor unit receives "  " signal, while it displays indoor set temperature.
- It's defaulted to display set temperature when turning on the unit. There is no display in the remote controller.
- Only for the models whose indoor unit has dual-8 display.
- When selecting displaying of indoor or outdoor ambient temperature, indoor temperature indicator displays corresponding temperature and automatically turn to display set temperature after three or five seconds.

WiFi button

Press " WiFi " button to turn on WiFi function, " WiFi " icon will be displayed on the remote controller. Hold " WiFi " button for 5s to turn off WiFi function and " WiFi " icon will disappear. Under off status, press "MODE" and " WiFi " buttons simultaneously for 1s, WiFi module will restore factory settings.

Notice :

- This function is only available for some models.

LIGHT button

Press this button to turn off display light on indoor unit. "  " icon on remote controller disappears.

Press this button again to turn on display light. "  " icon is displayed.

CLOCK button

Press this button to set clock time. "  " icon on remote controller will blink. Press "▲" or "▼" button within 5s to set clock time. Each pressing of "▲" or "▼" button, clock time will increase or decrease 1 min. If hold "▲" or "▼" button, 2s later, time will

change quickly. Release this button when reaching your required time. Press "CLOCK" button to confirm the time. "🕒" icon stops

Notice :

- Clock time adopts 24-hour mode.
- The interval between two operations can't exceed 5s. Otherwise, remote controller will quit setting status. Operation for TIMER ON/TIMER OFF is the same.

 button

• TIMER ON button

"TIMER ON" button can set the time for timer on. After pressing this button, "🕒" icon disappears and the word "ON" on remote controller blinks. Press "▲" or "▼" button to adjust TIMER ON setting. After each pressing "▲" or "▼" button, TIMER ON setting will increase or decrease 1min. Holding "▲" or "▼" button, 2s later, the time will change quickly until reaching your required time.

Press "TIMER ON" to confirm it. The word "ON" will stop blinking. "🕒" icon resumes displaying. Cancel TIMER ON: Under the condition that TIMER ON is started up, press "TIMER ON" button to cancel it.

• TIMER OFF button

"TIMER OFF" button can set the time for timer off. After pressing this button, "🕒" icon disappears and the word "OFF" on remote controller blinks. Press "▲" or "▼" button to adjust TIMER OFF setting. After each pressing "▲" or "▼" button, TIMER OFF setting will increase or decrease 1min. Holding "▲" or "▼" button, 2s later, the time will change quickly until reaching your required time.

Press "TIMER OFF" and the word "OFF" will stop blinking. "🕒" icon

Notice :

- Under on and off status, you can set TIMER OFF or TIMER ON simultaneously.
- Before setting TIMER ON or TIMER OFF, please adjust the clock time.
- After starting up TIMER ON or TIMER OFF, set the constant circulating valid. After that, air conditioner will be turned on or turned off according to setting time. "🔒" button has no effect on setting. If you don't need this function, please use remote controller to cancel it.

Function introduction for combination buttons

Energy-saving function

Under cooling mode, press "TEMP" and "CLOCK" buttons simultaneously to start up or turn off energy-saving function. When energy-saving function is started up, "SE" will be shown on remote controller, and air conditioner will adjust the set temperature automatically according to ex-factory setting to reach to the best energy-saving effect. Press "TEMP" and "CLOCK" buttons simultaneously again to exit energy-saving function.

Notice :

- Under energy-saving function, fan speed is defaulted at auto speed and it can't be adjusted.
- Under energy-saving function, set temperature can't be adjusted. Press "TURBO" button and the remote controller won't send signal.
- Sleep function and energy-saving function can't operate at the same time. If energy-saving function has been set under cool mode, press sleep button will cancel energy-saving function. If sleep function has been set under cool mode, start up the energy-saving function will cancel sleep function.

8°C heating function

Under heat mode, press "TEMP" and "CLOCK" buttons simultaneously to start up or turn off 8°C heating function. When this function is started up, "🌡" and "8°C" will be shown on

Notice :

- Under 8°C heating function, fan speed is defaulted at auto speed and it can't be adjusted.
- Under 8°C heating function, set temperature can't be adjusted. Press "TURBO" button and the remote controller won't send signal.
- Sleep function and 8°C heating function can't operate at the same time. If 8°C heating function has been set under heat mode, press sleep button will cancel 8°C heating function. If sleep function has been set under heat mode, start up the 8°C heating function will cancel sleep function.
- Under °F temperature display, the remote controller will display 46°F heating.

Child lock function

Press "▲" and "▼" simultaneously to turn on or turn off child lock function. When child lock function is on, "🔒" icon is displayed on remote controller. If you operate the remote controller, the "🔒" icon will blink three times without sending signal to the unit.

Temperature display switchover function

Under OFF status, press "▼" and "MODE" buttons simultaneously to switch temperature display between °C and °F.

I FEEL Function

Press "▲" and "MODE" buttons simultaneously to start I FEEL function and "🌡" will be displayed on the remote controller. After this function is set, the remote controller will send the detected ambient temperature to the controller and the unit will automatically adjust the indoor temperature according to the detected temperature. Press this two buttons simultaneously again to close I FEEL function and "🌡" will disappear. Please put the remote controller near user when this function is set. Do not put the remote controller near the object of high temperature or low temperature in order to avoid detecting inaccurate ambient temperature. When I FEEL function is turned on, the remote controller should be put within the area where indoor unit can receive the signal sent by the remote controller.

6.2 GREE+ App Operation Manual

Control Flow Chart

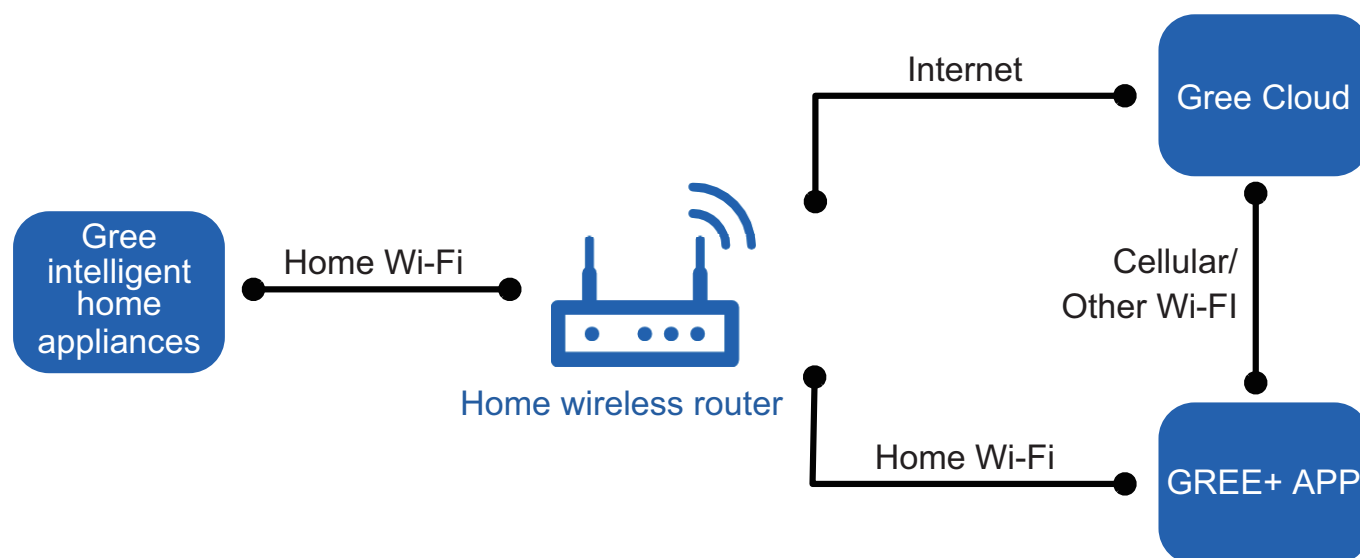

Operating Systems

Requirement for Users smart phone:



iOS system
Support iOS7.0 and
above version



Android system
Support Android 4.4 and
above version

Download and installation



GREE+ App Download Linkage

Scan the QR code or search "GREE+" in the application market to download and install it. When "GREE+" App is installed, register the account and add the device to achieve long-distance control and LAN control of Gree smart home appliances. For more information, please refer to "Help" in App.

6.4 Brief Description of Modes and Functions

● Indoor Unit

1. Basic function of system

(1) Cooling mode

- (1) Under this mode, fan and swing operates at setting status. Temperature setting range is 16~30°C.
- (2) During malfunction of outdoor unit or the unit is stopped because of protection, indoor unit keeps original operation status.

(2) Drying mode

- (1) Under this mode, fan operates at low speed and swing operates at setting status. Temperature setting range is 16~30°C.
- (2) During malfunction of outdoor unit or the unit is stopped because of protection, indoor unit keeps original operation status.
- (3) Protection status is same as that under cooling mode.
- (4) Sleep function is not available for drying mode.

(3) Heating mode

- (1) Under this mode, Temperature setting range is 16~30°C.
- (2) Working condition and process for heating mode:
When turn on the unit under heating mode, indoor unit enters into cold air prevention status. When the unit is stopped or at OFF status, and indoor unit has been started up just now, the unit enters into residual heat-blowing status.

(4) Working method for AUTO mode:

1. Working condition and process for AUTO mode:
 - a. Under auto mode set temperature can be adjusted. The unit switch mode automatically according to ambient temperature.
2. Protection function
 - a. During cooling operation, protection function is same as that under cooling mode.
 - b. During heating operation, protection function is same as that under heating mode.
3. Display: Set temperature is the set value under each condition. Ambient temperature is (Tamb.-Tcompensation) for heat pump unit and Tamb. for cooling only unit.
4. If theres I feel function, Tcompensation is 0. Others are same as above.

(5) Fan mode

Under this mode, indoor fan operates at set fan speed. Compressor, outdoor fan, 4-way valve and electric heating tube stop operation. Indoor fan can select to operate at high, medium, low or auto fan speed. Temperature setting range is 16~30°C.

2. Other control

(1) Buzzer

Upon energization or availably operating the unit or remote controller, the buzzer will give out a beep.

(2) Auto button

If press this auto button when turning off the unit, the complete unit will operate at auto mode. Indoor fan operates at auto fan speed and swing function is turned on. Press this auto button at ON status to turn off the unit.

(3) Auto fan

Heating mode: During auto heating mode or normal heating ode, auto fan speed will adjust the fan speed automatically according to ambient temperature and set temperature.

(4) Sleep

After setting sleep function for a period of time, system will adjust set temperature automatically.

(5) Timer function:

General timer and clock timer functions are compatible by equipping remote controller with different functions.

(6) Memory function

memorize compensation temperature, off-peak energization value.

Memory content: mode, up&down swing, light, set temperature, set fan speed, general timer (clock timer cant be memorized).

After power recovery, the unit will be turned on automatically according to memory content.

(7) Health function

During operation of indoor fan, set health function by remote controller. Turn off the unit will also turn off health function.

Turn on the unit by pressing auto button, and the health is defaulted ON.

(8)I feel control mode

After controller received I feel control signal and ambient temperature sent by remote controller, controller will work according to the ambient temperature sent by remote controller.

(9)Entry condition for compulsory defrosting function

When turn on the unit under heating mode and set temperature is 16°C (or 16.5°C by remote controller), press "+, -, +, -, +, -" button successively within 5s and then indoor unit will enter into compulsory defrosting setting status:

(1) If there's only indoor units controller, it enters into indoor normal defrosting mode.

(2) If there's indoor units controller and outdoor units controller, indoor unit will send compulsory defrosting mode signal to outdoor unit and then outdoor unit will operate under normal defrosting mode. After indoor unit received the signal that outdoor unit has entered into defrosting status, indoor unit will cancel to send compulsory mode to outdoor unit. If outdoor unit hasn't received feedback signal from outdoor unit after 3min, indoor unit will also cancel to send compulsory defrosting signal.

(10)Refrigerant recovery function:

Enter into Freon recovery mode actively: Within 5min after energization, turn on the unit at 16°C under cooling mode, and press light button for 3 times within 3s to enter into Freon recovery mode. Fo is displayed and Freon recovery mode will be sent to outdoor unit.

(11)Ambient temperature display control mode

1. When user set the remote controller to display set temperature (corresponding remote control code: 01), current set temperature will be displayed.

2. Only when remote control signal is switched to indoor ambient temperature display status (corresponding remote control code: 10) from other display status (corresponding remote control code: 00, 01,11),controller will display indoor ambient temperature for 3s and then turn back to display set temperature.

Under this mode, indoor fan operates at set fan speed. Compressor, outdoor fan, 4-way valve and electric heating tube stop operation. Indoor fan can select to operate at high, medium, low or auto fan speed. Temperature setting range is 16~30°C.

(12)Off-peak energization function:

Adjust compressors minimum stop time. The original minimum stop time is 180s and then we change to:

The time interval between two start-ups of compressor can't be less than $180+T_s(0\leq T\leq 15)$. T is the variable of controller. That's to say the minimum stop time of compressor is 180s~195s. Read-in T into memory chip when refurbish the memory chip each time. After power recovery, compressor can only be started up after $180+T$ s at least.

(13) SE control mode

The unit operates at SE status.

(14) X-fan mode

When X-fan function is turned on, after turn off the unit, indoor fan will still operate at low speed for 2min and then the complete unit will be turned off. When x-fan function is turned off, after turn off the unit, the complete unit will be turned off directly.

(15) 8°C heating function

Under heating mode, you can set 8°C heating function by remote controller. The system will operate at 8°C set temperature.

(16)Turbo function

Turbo function can be set under cooling and heating modes. Press Fan Speed button to cancel turbo setting. Turbo function is not available under auto, drying and fan modes.

● Outdoor Unit

09/12K

1. Cooling mode:

Working condition and process of cooling mode:

- ① When Tindoor ambient temperature $\geq T_{\text{preset}}$, unit enters into cooling mode. Indoor fan, outdoor fan and compressor start operation. Indoor fan operates according to set fan speed.
- ② When Tindoor ambient temperature $\leq T_{\text{preset}} - 2^{\circ}\text{C}$, compressor stops operation and outdoor fan will stop 30s later. Indoor fan operates according to set fan speed.
- ③ When $T_{\text{preset}} - 2^{\circ}\text{C} < \text{Tindoor ambient temperature} < T_{\text{preset}}$, unit operates according to the previous status.

Under cooling mode, 4-way valve is not energized. Temperature setting range is $16\sim 30^{\circ}\text{C}$. If compressor stops because of malfunction in cooling mode, indoor fan and swing motor will work according to the original status.

2. Drying mode

(1) Working condition and process of drying mode

- ① When Tindoor ambient temperature $> T_{\text{preset}}$, unit will be in drying mode. Outdoor fan and compressor start operation while indoor fan will operate at low fan speed.
- ② When $T_{\text{preset}} - 2^{\circ}\text{C} \leq \text{Tindoor ambient temperature} \leq T_{\text{preset}}$, unit operates according to the previous status.
- ③ When Tindoor ambient temperature $< T_{\text{preset}} - 2^{\circ}\text{C}$, compressor stops operation and outdoor fan will stop 30s later.

(2) Under drying mode, 4-way valve is not energized. Temperature setting range is $16\sim 30^{\circ}\text{C}$.

(3) Protection function: same as in cooling mode.

3. Fan mode

(1) Under this mode, indoor fan can select different fan speed (except Turbo) or auto fan speed. Compressor, outdoor fan and 4-way valve all stop operation.

(2) In fan mode, temperature setting range is $16\sim 30^{\circ}\text{C}$.

4. Heating mode

Working condition and process of heating mode:

- ① When $T_{\text{preset}} - (\text{Tindoor ambient temperature} - T_{\text{compensation}}) \geq 1^{\circ}\text{C}$, unit enters into heating mode. Compressor, outdoor fan and 4-way valve start operation.
- ② When $-2^{\circ}\text{C} < T_{\text{preset}} - (\text{Tindoor ambient temperature} - T_{\text{compensation}}) < 1^{\circ}\text{C}$, unit operates according to the previous status.
- ③ When $T_{\text{preset}} - (\text{Tindoor ambient temperature} - T_{\text{compensation}}) \leq -2^{\circ}\text{C}$, compressor stops operation and outdoor fan will stop 30s later. Indoor fan will be in residual-heat blowing status.
- ④ When unit is turned off under heating mode or changed to other modes from heating mode, 4-way valve will be power-off 2min after compressor stops working (compressor is in operation status under heating mode).
- ⑤ When Tindoor ambient temperature $> 30^{\circ}\text{C}$, compressor stops operation immediately. Outdoor fan will stop 30s later.
- ⑥ Under the condition that compressor is turned on, when unit is changed to heating mode from cooling or drying mode, 4-way valve will be energized in 2~3mins delay.

Note: Tcompensation is determined by IDU and ODU. If IDU controls the compensation temperature, then Tcompensation is determined according to the value sent by IDU to ODU; If IDU does not control the compensation temperature, then Tcompensation will default to 3°C by the ODU.

5. Freon recovery mode

After the Freon recovery signal from IDU is received, cooling at rated frequency will be forcibly turned on to recover Freon.

Indoor unit will display Fo. If any signal from remote controller is received, unit will exit from Freon recovery mode and indoor unit stops displaying Fo.

6. Compulsory defrosting

If unit is turned on under heating mode and set temperature is 16°C (by remote controller), press "+, -, +, -, +, -" within 5s, unit will enter into compulsory defrosting mode and send the signal to ODU. When the compulsory defrosting signal from ODU is received, IDU will exit from the compulsory defrosting mode and stop sending the signal to ODU.

After ODU receives the compulsory defrosting code, it will start compulsory defrosting. Defrosting frequency and opening angle will be the same as in normal defrosting mode. When compulsory defrosting is finished, the complete unit resumes original status.

7. Auto mode

Auto mode is determined by controller of IDU. See IDU logic for details.

8. 8°C heating

Set temperature is 8°C. Display board of IDU displays 8°C. Under this mode, “Cold air prevention” function is shielded.

If compressor is operating under this mode, fan speed will adjust according to auto fan speed; if compressor stops operation under this mode, indoor fan will be in residual-heat blowing status.

When power on, communication light will be blinking in a normal way (after receiving a group of correct signals, blinking stops for 0.2s~0.3s). If there's no communication, communication light will be always on. If other ODU has malfunction, communication light will be on for 1s and off for 1s in a circular way.

18/24K

● Outdoor Unit

1. Input Parameter Compensation and Calibration

(1) Check the ambient temperature compensation function Indoor ambient temperature compensation function.

a. In cooling mode, the indoor ambient temperature participating in computing control = $(T_{\text{indoor ambient temperature}} - \Delta T_{\text{cooling indoor ambient temperature compensation}})$

b. In heating mode, the indoor ambient temperature participating in computing control = $(T_{\text{indoor ambient temperature}} - \Delta T_{\text{heating indoor ambient temperature compensation}})$

(2) Check effective judgment controls of parameters

Effective judgment function of the outdoor exhaust temperature thermo-bulb When conditions a and b are satisfied, the outdoor exhaust temperature thermo-bulb is judged not to be connected into place, the mainboard of outer units will display failure of the outdoor exhaust temperature thermo-bulb (not connected into place), stop the machine for repairing, and resume the machine by remote controls of ON/OFF.

a. Judgment of exhaust detection temperature change:

After the compressor starts up and runs for 10 minutes, if the compressor frequency $f \geq 40\text{Hz}$, and the rising value T_{exhaust} (T_{exhaust} (after start-up for 10 minutes) - T_{exhaust} (before start-up)) $< 2^{\circ}\text{C}$, the outdoor exhaust temperature thermo-bulb can be judged not to be connected into place (judging once when the power is on the first time).

b. Comparative judgment of exhaust detection temperature and condenser detection temperature ($T_{\text{pipe temperature}} = T_{\text{outdoor pipe temperature in cooling mode}}$, $T_{\text{pipe temperature}} = T_{\text{indoor pipe temperature in heating mode}}$): After the compressor starts up and runs for 10 minutes, if the compressor frequency $f \geq 40\text{Hz}$, and $T_{\text{pipe temperature}} \geq (T_{\text{exhaust}} + 3)$, the outdoor exhaust temperature thermobulb can be judged not to be connected into place (judging once when power is on the first time).

2. Basic Functions**(1) Cooling Mode****1. Conditions and processes of cooling operation:**

(1) If the compressor is shut down, and $[T_{\text{setup}} - (T_{\text{indoor ambient temperature}} - \Delta T_{\text{cooling indoor ambient temperature compensation}})] \leq 0.5$, start up the machine for cooling, the cooling operation will start;

(2) During operations of cooling, if $0^{\circ}\text{C} \leq [T_{\text{setup}} - (T_{\text{indoor ambient temperature}} - \Delta T_{\text{cooling indoor ambient temperature compensation}})] < 2$, the cooling operation will be still running;

(3) During operations of cooling, if $2^{\circ}\text{C} \leq [T_{\text{setup}} - (T_{\text{indoor ambient temperature}} - \Delta T_{\text{cooling indoor ambient temperature compensation}})]$, the cooling operation will stop after reaching the temperature point.

2. Temperature setting range

(1) If $T_{\text{outdoor ambient temperature}} \geq [T_{\text{low-temperature cooling temperature}}]$, the temperature can be set at: $16\sim 30^{\circ}\text{C}$ (Cooling at room temperature);

(2) If $T_{\text{outdoor ambient temperature}} < [T_{\text{low-temperature cooling temperature}}]$, the temperature can be set at: $25\sim 30^{\circ}\text{C}$ (Cooling at low temperature), that is, the minimum setting temperature for outer units judgment is 25°C .

(2) Dehumidifying Mode

1. Conditions and processes of dehumidifying operations: Same as the cooling mode;

2. The temperature setting range is: $16\sim 30^{\circ}\text{C}$;

(3) Air-supplying Mode

1. The compressor, outdoor fans and four-way valves are switched off;

2. The temperature setting range is: $16\sim 30^{\circ}\text{C}$.

(4) Heating Mode

1. Conditions and processes of heating operations: ($T_{\text{indoor ambient temperature}}$ is the actual detection temperature of indoor environment thermo-bulb, $T_{\text{heating indoor ambient temperature compensation}}$ is the indoor ambient temperature compensation during heating operations)

(1) If the compressor is shut down, and $[(T_{\text{indoor ambient temperature}} - \Delta T_{\text{heating indoor ambient temperature compensation}}) - T_{\text{setup}}] \leq 0.5$, start the machine to enter into heating operations for heating;

(2) During operations of heating, if $0^{\circ}\text{C} \leq [(T_{\text{indoor ambient temperature}} - \Delta T_{\text{heating indoor ambient temperature compensation}}) - T_{\text{setup}}] < 2$, the heating operation will be still running;

(3) During operations of heating, if $2^{\circ}\text{C} \leq [(T_{\text{indoor ambient temperature}} - \Delta T_{\text{heating indoor ambient temperature compensation}}) - T_{\text{setup}}]$, the heating operation will stop after reaching the temperature point.

2. The temperature setting range in this mode is: $16\sim 30^{\circ}\text{C}$.

3. Special Functions

Defrosting Control

① Conditions for starting defrosting

After the time for defrosting is judged to be satisfied, if the temperature for defrosting is satisfied after detections for continuous 3minutes, the defrosting operation will start.

② Conditions of finishing defrosting

The defrosting operation can exit when any of the conditions below is satisfied:

③ $T_{\text{outdoor pipe temperature}} \geq (T_{\text{outdoor ambient temperature}} - [T_{\text{temperature 1 of finishing defrosting}}])$;

④ The continuous running time of defrosting reaches [tmax. defrosting time].

4. Control Logic

(1) Compressor Control

Start the compressor after starting cooling, heating, dehumidifying operations, and the outer fans start for 5s; When the machine is shutdown, in safety stops and when switching to air-supplying mode, the compressor will stop immediately. In all modes: once the compressor starts up, it will not be allowed to stop until having run for the [tmin. compressor running time] (Note: including cases of shutdown when the temperature point is reached; except the cases requiring stopping the compressor such as fault protection, remote shutdown, mode switching etc.); In all modes: once the compressor stops, it will be allowed be restart after 3-minute delay (Note: The indoor units have a function of power memory, the machine can be restarted after remote shutdown and powering up again without delay).

1. Cooling mode

Start the machine to enter into cooling operation for cooling, the compressor is switched on.

2. Dehumidifying mode

Same as the cooling mode.

3. Air-supplying mode

The compressor is switched off.

4. Heating mode

(1) Start the machine to enter into heating operation for heating, the compressor is switched on.

(2) Defrosting:

a. Defrosting starts: the compressor is shut down, and restarts it after 55-second delay.

b. Defrosting ends: the compressor stops, then starts it after 55-second delay.

(2) Outer Fans Control

Notes:

Only the outer fans run for at least 80s in each air flow speed can the air flow be switched;

After the outer fans run compulsively in high speed for 80s when the machine starts up, control the air flow according to the logic.

After remote shutdown, safety stops, and when the machine stops after reaching the temperature point, as well as after the compressor stops, extend 1 minute, the outer fans will stop (During the period in the 1 minute, the air flow of outer fans can be changed according to the outdoor ambient temperature changes); When running with force, the outdoor fans shall run in the highest air flow.

(3) 4-way valve control

1. The 4-way valve control under the modes of Cooling, dehumidification and supplying air: closing;

2. The status of 4-way valve control under the heating mode: getting power;

(1) 4-way valve power control under heating mode

a. Starts the machine under heating mode, the 4-way valve will get power immediately.

(2) 4-way valve power turn-off control under heating mode

a. When you should turn off the power or switch to other mode under heating mode, the power of 4-way valve will be cut after 2 minutes of the compressor stopped.

b. When all kinds of protection stops, the power of 4-way valve will be cut after delaying 4 minutes.

(3) Defrosting control under heating mode:

a. Defrosting begins: The power of 4-way valve will be cut after 50s of entering into the defrosting compressor.

b. Defrosting stops: The 4-way valve will get power after 50s of exiting the defrosting compressor.

(4) Evaporator frozen-preventing protection function

At the mode of Cooling, dehumidifying:

Evaporator frozen-preventing protection function is allowed to begin after 6 min of starting the compressor.

1. Starting estimation:

After the compressor stopped working for 180s, if $T_{\text{inner pipe}} > [T_{\text{frozen-preventing frequency-limited temperature}}]$ (the temperature of hysteresis is 2 °C), the machine is only allowed to start for operating, otherwise it should not be started, and should be stopped to treat according to the frozen-preventing protection: Clear the trouble under the mode of power turn-off / heating, and the protection times are not counted.

2. Frequency limited

$[T_{\text{frozen-preventing normal speed frequency-reducing temperature}}] \leq [T_{\text{inner pipe}} T_{\text{frozen-preventing frequency-limited temperature}}]$, you should limit the frequency raising of compressor.

3. Reducing frequency at normal speed:

If $[T_{\text{frozen-preventing high speed frequency-reducing temperature}}] \leq [T_{\text{inner pipe}} T_{\text{frozen-preventing normal speed frequency-reducing temperature}}]$, you should adjust the compressor frequency by reducing 8Hz/90s till the lower limit;

4. Reducing frequency at high speed:

If $[T_{\text{frozen-preventing power turn-off temperature}}] \leq T_{\text{inner pipe}} [T_{\text{frozen-preventing high speed frequency-reducing temperature}}]$ you should adjust the compressor frequency by reducing 30Hz/90s till the lower limit;

5. Power turn-off:

If the $T_{\text{inner pipe}} < [T_{\text{frozen-preventing power turn-off temperature}}]$, then frozen-preventing protect to stop the machine; If $T_{\text{frozen-preventing frequency-limited temperature}} < T_{\text{inner pipe}}$, and the compressor has stopped working for 3 minutes, the whole machine should be allowed to operate.

6. If the frozen-preventing protection power turn-off continuously occurs for six times, it should not be resumed automatically, and you should press the ON/OFF button to resume if the fault keeps on. During the process of running, if the running time of compressor exceeds the t evaporator frozen-preventing protection times zero clearing time, the times of frozen-preventing power turn-off should be cleared to recount. The mode of stopping the machine or transferring to supply air will clear the trouble times immediately (if the trouble can not be resumed, mode transferring will not clear it).

(5) Overload protection function

Overload protection function at the mode of Cooling and dehumidifying

1. Starting estimation:

After the compressor stopped working for 180s, if $T_{\text{outer pipe}} < [T_{\text{Cooling overload frequency-limited temperature}}]$ (the temperature of hysteresis is 2°C), the machine is allowed to start, otherwise it should not be started, and should be stopped to treat according to the overload protection: Clear the trouble at the mode of power turn-off / heating, and the protection times are not counted.

2. Frequency limited

If $[T_{\text{Cooling overload frequency-limited temperature}}] \leq [T_{\text{outer pipe}} T_{\text{Cooling overload frequency reducing temperature at normal speed}}]$, you should limit the frequency raising of compressor.

3. Reducing frequency at normal speed and power turn-off:

If $[T_{\text{Cooling overload frequency reducing temperature at high speed}}] \leq T_{\text{outer pipe}} < [T_{\text{Cooling overload power turn-off temperature}}]$, you should adjust the compressor frequency by reducing 8Hz/90s till the lower limit; After it was running 90s at the lower limit, if $[T_{\text{Cooling overload frequency reducing temperature at normal speed}}] \leq T_{\text{outer pipe}}$, then Cooling overload protects machine stopping;

4. Reducing frequency at high speed and stop machine:

If $[T_{\text{Cooling overload frequency reducing temperature at high speed}}] \leq T_{\text{outer pipe}} [T_{\text{Cooling overload power turn-off temperature}}]$, you should adjust the compressor frequency by reducing 30Hz/90s till the lower limit; After it was running 90s at the lower limit, if $[T_{\text{Cooling overload frequency reducing temperature at normal speed}}] \leq [T_{\text{outer pipe}}]$, then Cooling overload protects machine stopping;

5. Power turn-off:

If the $[T_{\text{Cooling overload power turn-off temperature}}] \leq T_{\text{outer pipe}}$, then Cooling overload protects machine stopping; If $[T_{\text{outer pipe}}] < [T_{\text{Cooling overload frequency-limited temperature}}]$ and the compressor has been stopped working for 3 minutes, the machine should be allowed to operate.

6. If the Cooling overload protection power turn-off continuously occurs for six times, it should not be resumed automatically, and you should press the ON/OFF button to resume if the fault keeps on. During the process of running, if the running time of compressor exceeds the t overload protection times zero clearing time, the times of overload protection power turn-off should be cleared to recount. The mode of stopping the machine or transferring to supply air will clear the trouble times immediately (if the trouble can not be resumed, transferring mode will not clear it).

Overload protection function at the mode of heating**Starting estimation :**

After the compressor stopped working for 180s, if $T_{\text{inner pipe}} > [T_{\text{heating overload frequency-limited temperature}}]$ (the temperature of hysteresis is 2 °C), the machine is allowed to start, otherwise it should not be started, and should be stopped to treat according to the overload protection:

Clear the trouble at the mode of power turn-off / heating, and the protection times are not counted.

1. Frequency limited

If $[T_{\text{heating overload frequency-limited temperature}}] \leq T_{\text{inner pipe}} < [T_{\text{heating overload frequency reducing temperature at normal speed}}]$, you should limit the frequency raising of compressor.

2. Reducing frequency at normal speed and stopping machine:

If $[T_{\text{heating overload frequency reducing temperature at normal speed}}] \leq T_{\text{inner pipe}} < [T_{\text{heating overload frequency reducing temperature at high speed}}]$, you should adjust the compressor frequency by reducing 8Hz/90s till the lower limit; After it was running 90s at the lower limit, if $T_{\text{heating overload frequency reducing temperature at normal speed}} \leq T_{\text{inner pipe}}$, then overload protects machine stopping;

3. Reducing frequency at high speed and power turn-off:

If $[T_{\text{heating overload frequency reducing temperature at high speed}}] \leq T_{\text{inner pipe}} < [T_{\text{heating overload power turn-off temperature}}]$, you should adjust the compressor frequency by reducing 30Hz/90s till the lower limit; After it was running 90s at the lower limit, if $T_{\text{heating overload frequency reducing temperature at normal speed}} \leq T_{\text{outer pipe}}$, then Cooling overload protects machine stopping;

4. Power turn-off:

If the $[T_{\text{heating overload power turn-off temperature}}] \leq T_{\text{inner pipe}}$, then overload protects machine stopping; If $T_{\text{inner pipe}} > T_{\text{heating overload frequency-limited temperature}}$ and the compressor has been stopped working for 3 minutes, the machine should be allowed to operate.

5. If the overload protection power turn-off continuously occurs for six times, it should not be resumed automatically, and you should press the ON/OFF button to resume if the fault keeps on. During the process of running, if the running time of compressor exceeds the $t_{\text{overload protection times zero clearing time}}$, the times of overload protection power turn-off should be cleared to recount. The mode of stopping the machine or transferring to supply air will clear the trouble times immediately (if the trouble can not be resumed, transferring mode will not clear it). Protective function for discharge temperature of compressor

1. Starting estimation:

After the compressor stopped working for 180s, if $T_{\text{Discharge}} < T_{\text{Discharge limited temperature}}$ (the temperature of hysteresis is 2°C), the machine is allowed to start, otherwise it should not be started, and should be stopped to treat according to the discharge temperature:

The machine should be stopped or transferred to supply air, the trouble should be cleared immediately, and the protection times are not counted.

2. Frequency limited

If $[T_{\text{limited frequency temperature during discharging}}] \leq T_{\text{Discharge}} < [T_{\text{frequency reducing temperature at normal speed during discharging}}]$, you should limit the frequency raising of compressor.

3. Reducing frequency at normal speed and stopping machine:

If $[T_{\text{frequency reducing temperature at normal speed during discharging}}] \leq T_{\text{Discharge}} < [T_{\text{frequency reducing temperature at high speed during discharging}}]$, you should adjust the compressor frequency by reducing 8Hz/90s till the lower limit; After it was running 90s at the lower limit, if $[T_{\text{frequency reducing temperature at normal speed during discharging}}] \leq T_{\text{Discharge}}$, you should discharge to protect machine stopping;

4. Reducing frequency at high speed and power turn-off:

If $[T_{\text{frequency reducing temperature at high speed during discharging}}] \leq T_{\text{Discharge}} < [T_{\text{Stop temperature during discharging}}]$, you should adjust the compressor frequency by reducing 30Hz/90s till the lower limit; After it was running 90s at the lower limit, if $[T_{\text{frequency reducing temperature at normal speed during discharging}}] \leq T_{\text{Discharge}}$, you should discharge to protect machine stopping;

5. Power turn-off:

If the $[T_{\text{Power turn-off temperature during discharging}}] \leq T_{\text{Discharge}}$, you should discharge to protect machine stopping; If $[T_{\text{Discharge}}] < [T_{\text{limited frequency temperature during discharging}}]$ and the compressor has been stopped for 3 minutes, the machine should be allowed to operate.

6. If the discharging temperature protection of compressor continuously occurs for six times, it should not be resumed automatically, and you should press the ON/OFF button to resume. During the process of running, if the running time of compressor exceeds the $t_{\text{Protection times clearing of discharge}}$, the discharge protection is cleared to recount. Stopped or transferred to supply air mode will clear the trouble times immediately (if the trouble can not be resumed, mode transferring also will not clear it).

7. Frequency limited

If $[I_{\text{limited frequency when overcurrent}}] \leq I_{\text{AC Electric current}} < [I_{\text{frequency reducing when overcurrent}}]$, you should limit the frequency raising of compressor.

8. Reducing frequency:

If $[I_{\text{frequency reducing when overcurrent}}] \leq [I_{\text{AC Electric current}} \text{ I Power turn-off when overcurrent}]$, you should reduce the compressor frequency till the lower limit or exit the frequency reducing condition;

9. Power turn-off:

If $[I_{\text{Power turn-off machine when overcurrent}}] \leq [I_{\text{AC Electric current}}]$, you should carry out the overcurrent stopping protection; If $I_{\text{AC Electric current}} < [I_{\text{limited frequency when overcurrent}}]$ and the compressor has been stopped for 3 minutes, the machine should be allowed to operate.

10. If the overcurrent protection continuously occurs for six times, it should not be resumed automatically, and you should press the ON/OFF button to resume. During the process of running, if the running time of compressor exceeds the $[t_{\text{Protection times clearing of over current}}]$, the discharge protection is cleared to recount.

(6) Voltage sag protection

After start the compressor, if the time of DC link Voltage sag [$U_{\text{Sagging protection voltage}}$] is measured to be less than $t_{\text{Voltage sag protection time}}$, the machine should be stop at once, hand on the voltage sag trouble, reboot automatically after 30 minutes.

(7) Communication fault

When you have not received any correct signal from the inner machine in three minutes, the machine will stop for communication fault. When you have not received any correct signal from driver IC (aim to the controller for the separating of main control IC and driver IC), and the machine will stop for communication fault. If the communication is resumed, the machine will be allowed to operate.

(8) Module protection

Testing the module protective signal immediately after started, once the module protective signal is measured, stop the machine with module protection immediately. If the module protection is resumed, the machine will be allowed to operate. If the module protection continuously occurs for three times, it should not be resumed automatically, and you should press the ON/OFF button to resume. If the running time of compressor exceeds the [$t_{\text{Protection times clearing of module}}$], the module protection is cleared to recount.

(9) Module overheating protection

1. Starting estimation:

After the compressor stopped working for 180s, if $T_{\text{Module}} < [T_{\text{Module frequency limited temperature}}]$ (the temperature of hysteresis is 2), the machine is allowed to start, otherwise it should not be started, and should be stopped to treat according to the module overheating protection: The machine should be stopped or transferred to supply air, the trouble should be cleared immediately, and the protection times are not counted.

2. Frequency limited

If $[T_{\text{Limited frequency temperature of module}}] \leq T_{\text{Module}} < [T_{\text{frequency reducing temperature at normal speed of module}}]$, you should limit the frequency raising of compressor.

3. Reducing frequency at normal speed and power turn-off:

If $[T_{\text{frequency reducing temperature at normal speed of module}}] \leq T_{\text{Module}} < [T_{\text{frequency reducing temperature at high speed of module}}]$, you should adjust the compressor frequency by reducing 8Hz/90s till the lower limit; After it was running 90s at the lower limit, if $[T_{\text{frequency reducing temperature at normal speed of module}}] \leq T_{\text{Module}}$, you should stop the machine for module overheating protection;

4. Reducing frequency at high speed and power turn-off:

If $[T_{\text{frequency reducing temperature at high speed of module}}] \leq T_{\text{Module}} < [T_{\text{Power turn-off temperature of module}}]$ you should adjust the compressor frequency by reducing 30Hz/90s till the lower limit; After it was running 90s at the lower limit, if $[T_{\text{frequency reducing temperature at normal speed of module}}] \leq T_{\text{Module}}$, you should stop the machine for module overheating protection;

5. Power turn-off:

If the $[T_{\text{Power turn-off temperature of module}}] \leq T_{\text{Module}}$, you should stop the machine for module overheating protection; If $T_{\text{Module}} < [T_{\text{Limited frequency temperature of module}}]$ and the compressor has been stopped for 3 minutes, the machine should be allowed to operate.

6. If protection continuously occurs for six times, it should not be resumed automatically, and you should press the ON/OFF button to resume. During the process of running, if the running time of compressor exceeds the [$t_{\text{Protection times clearing of module}}$], the discharge protection is cleared to recount. Stopped or transferred to supply air mode will clear the trouble times immediately (if the trouble can not be resumed, mode transferring also will not clear it).

(10) Compressor overloads protection

If you measure the compressor overload switch action in 3s, the compressor should be stopped for overloading. The machine should be allowed to operate after overload protection was measured to resume. If the overloading protection continuously occurs for three times, it should not be resumed automatically, and you should press the ON/OFF button to resume. The protection times of compressor is allowed to clear after the compressor run [$t_{\text{Protection times clearing of compressor overloading}}$] 30 minutes.

(11) Phase current overcurrent protection of compressor

During the running process of compressor, you could measure the phase current of the compressor, and control it according to the following steps:

1. Frequency limited

If $[I_{\text{Limited frequency phase current}}] \leq [I_{\text{Phase current T frequency reducing phase current}}]$, you should limit the frequency raising of compressor.

2. Reducing Frequency

If $[I_{\text{Frequency Reducing Phase Current}}] \leq I_{\text{Phase Current}} < [I_{\text{Power Turn-Off Phase Current}}]$, the compressor shall continue to reduce frequency till the lowest frequency limit or out of the condition of reducing frequency;

3. Power turn-off

If $[I_{\text{Phase Current}}] \geq [I_{\text{Power Turn-Off Phase Current}}]$, the compressor phase current shall stop working for overcurrent protection; if $[I_{\text{Phase Current}}] \leq [I_{\text{Frequency Reducing Phase Current}}]$, and the compressor have stopped working for 3 min, the machine shall be allowed to operate;

4. If the overcurrent protection of compressor phase current continuously occurs for six times, it should not be resumed automatically, and you should press the ON/OFF button to resume. During the process of running, if the running time of compressor exceeds the [$t_{\text{Clearing Time of Compressor Phase Current Times}}$], the overcurrent protection is cleared to recount.

(12) Starting-up Failure Protection for Compressor

Stop the compressor after its starting-up fails, restart it after 20s if the fault doesn't shows, and if they are all failing for the successive start 3 times, it shall be reported as Starting-up Failure, and then restart up it after 3 min. When it still not be able to operate through carry out the above process for 5 times, it is available if press ON/OFF. And the compressor should be cleared the times after it run 2 min.

(13) Out-of-Step Protection for Compressor

The out-of-step protection signal should be detected immediately after starting-up compressor, and once find the out-of-step protection signal, the out-of-step protection shall be stopped; if it can run for lasting power turn-off 3 min, the machine shall be allowed to operate. If it still can't run automatically when the out-of-step protection for compressor happens to stop working for 6 times in succession, it needs to press ON/OFF to operate. And if the running time is more than 10 min, the power turn-off times for out-of-step protection shall be cleared and recounted.

(14) Voltage Abnormity Protection for DC Bus

To detect voltage abnormity protection for dc bus after completing the pre-charge:

1. Over-High Voltage Protection for DC Bus:

If it found the DCbus voltage $U_{DC} > [UDC_{Jiekuangchun Protection}]$, turn off PFC and stop the compressor at once, and it shall show the DC over-high voltage failure; it should clear out the failure when the voltage dropped to $U_{DC} < [UDC_{Jiekuangchun Recovery}]$ and the compressor stopped for 3 min.

2. Over-Low Voltage Protection for DC Bus:

If it found the DC bus voltage $U_{DC} < [U_{DC Wantuochun Protection}]$, turn off PFC and stop the compressor at once, and it shall show the DC over-low voltage; and it should clear out the failure when the voltage raised to $U_{DC} > [U_{DC Wantuochun Recovery}]$ and the compressor stopped for 3 min.

3. To detect voltage abnormity protect for DC bus when getting electricity:

If it found the DC bus voltage $U_{DC} > [U_{DC Over-High Voltage}]$, turn off the relay at once, and shows voltage abnormity failure for DC Bus. And the failure can't recover except to break off and get the electricity.

(15) Abnormity Protection for Four-way Valve

Under the model of heating operation in good condition: the compressor is detected $[T_{Inner Tube} < (T_{Inner Ring} - T_{Abnormity Temperature Difference For Four-Way Valve Reversion})]$, during the running, it should be regarded as four-way valve reversion abnormity. And then it can run if stop the reversion abnormity protection for four-way valve 3 min; and if it still can't run when the reversion abnormity protection for four-way valve happens to stop working for 3 times in succession, it is available if presses ON/OFF.

Attention: the protection shall be shielded during the testing mode and defrosting process, and it shall be cleared out the failure and its times immediately when turning off or delivering wind / cooling / dehumidifying mode conversed (the inverted mode don't clear out the failure when it can't recover to operate).

(16) PFC Protection

1. After start up the PFC, it should detect the protection signal of PFC immediately; under the condition of PFC protection, it should turn off the PFC and compressor at one time;
2. It shows the failure is cleared out if PFC Protection stopped working 3 min and recovers to run automatically;
3. If it still can't run when it occurs PFC protection for 3 times in succession, it is available if presses ON/OFF; and clear the PFC Protection times when start up PFC for 10min.

(17) Failure Detection for Sensor

1. Outdoor Ambient Sensor: detect the failure of sensor at all times.
2. Outdoor Tube Sensor: You should not detect the failure of outdoor tube sensor within 10 minutes heating operation compressor except the defrosting, and you could detect it at other time.
3. Outdoor Exhaust Sensor:
 - (a) The compressor only detect the sensor failure after it start up 3 min in normal mode;
 - (b) It should detect the exhaust sensor failure immediately in the testing mode.
4. Module Temperature Sensor:
 - (a) Short-Circuit Detection: the compressor should be detected immediately when the module temperature sensor occurs short-circuits;
 - (b) Open-Circuit Detection: the compressor should be detected on open-circuit when it runs 3min (it needn't 30s avoiding the module over-heated).
 - (c) Detect the sensor failure at all times in the testing mode.
5. Disposal for Sensor Protection
 - (1) When the short-circuit of sensor is detected within 30s, It is regarded as the temperature of sensor over-high (or infinitely high), and now according to the over-high sensor, the machine should carry out the corresponding protection to stop working, and show the corresponding temperature shutdown protection and sensor failure at the same time (for example: the compressor stops immediately when the outdoor tube sensor short-circuit, and the machine shall show the overload protection and outdoor tube sensor failure).
 - (2) When the open-circuit of sensor is detected within 30s, The protection shall be stopped and it shall show the corresponding sensor failure.

6. Electric Heating Function of Chassis

- (1) When Toutdoor amb. ≤ 0 , the electric heating of chassis will operate;
- (2) When Toutdoor amb. > 2 , the electric heating of chassis will stop operation;
- (3) When $0 < \text{Toutdoor amb.} \leq 2$, the electric heating of chassis will keep original status.

7. Electric Heating Function of Compressor

- (1) When Toutdoor amb. ≤ -5 , compressor stops operation, while the electric heating of compressor starts operation;
- (2) When Toutdoor amb. > -2 , the electric heating of compressor stops operation;
- (3) When $-5 < \text{Toutdoor amb.} \leq -2$, the electric heating of compressor will keep original status.

Part II : Installation and Maintenance

7. Notes for Installation and Maintenance

Safety Precautions: Important!

Please read the safety precautions carefully before installation and maintenance.

The following contents are very important for installation and maintenance.

Please follow the instructions below.

- The installation or maintenance must accord with the instructions.
- Comply with all national electrical codes and local electrical codes.
- Pay attention to the warnings and cautions in this manual.
- All installation and maintenance shall be performed by distributor or qualified person.
- All electric work must be performed by a licensed technician according to local regulations and the instructions given in this manual.
- Be caution during installation and maintenance. Prohibit incorrect operation to prevent electric shock, casualty and other accidents.



Warnings

Electrical Safety Precautions:

1. Cut off the power supply of air conditioner before checking and maintenance.
2. The air condition must apply specialized circuit and prohibit share the same circuit with other appliances.
3. The air conditioner should be installed in suitable location and ensure the power plug is touchable.
4. Make sure each wiring terminal is connected firmly during installation and maintenance.
5. Have the unit adequately grounded. The grounding wire cant be used for other purposes.
6. Must apply protective accessories such as protective boards, cable-cross loop and wire clip.
7. The live wire, neutral wire and grounding wire of power supply must be corresponding to the live wire, neutral wire and grounding wire of the air conditioner.
8. The power cord and power connection wires cant be pressed by hard objects.
9. If power cord or connection wire is broken, it must be replaced by a qualified person.

10. If the power cord or connection wire is not long enough, please get the specialized power cord or connection wire from the manufacture or distributor. Prohibit prolong the wire by yourself.

11. For the air conditioner without plug, an air switch must be installed in the circuit. The air switch should be all-pole parting and the contact parting distance should be more than 3mm.

12. Make sure all wires and pipes are connected properly and the valves are opened before energizing.

13. Check if there is electric leakage on the unit body. If yes, please eliminate the electric leakage.

14. Replace the fuse with a new one of the same specification if it is burnt down; dont replace it with a cooper wire or conducting wire.

15. If the unit is to be installed in a humid place, the circuit breaker must be installed.

Installation Safety Precautions:

When refrigerant leaks or requires discharge during installation, maintenance, or disassembly, it should be handled by certified professionals or otherwise in compliance with local laws and regulations.

1. Select the installation location according to the requirement of this manual.(See the requirements in installation part)
2. Handle unit transportation with care; the unit should not be carried by only one person if it is more than 20kg.
3. When installing the indoor unit and outdoor unit, a sufficient fixing bolt must be installed; make sure the installation support is firm.
4. Ware safety belt if the height of working is above 2m.
5. Use equipped components or appointed components during installation.
6. Make sure no foreign objects are left in the unit after finishing installation.

Improper installation may lead to fire hazard, explosion, electric shock or injury.

Safety Precautions for Installing and Relocating the Unit:

To ensure safety, please be mindful of the following precautions.



Warnings

1. When installing or relocating the unit, be sure to keep the refrigerant circuit free from air or substances other than the specified refrigerant.

Any presence of air or other foreign substance in the refrigerant circuit will cause system pressure rise or compressor rupture, resulting in injury.

2. When installing or moving this unit, do not charge the refrigerant which is not comply with that on the nameplate or unqualified refrigerant.

Otherwise, it may cause abnormal operation, wrong action, mechanical malfunction or even series safety accident.

3. When refrigerant needs to be recovered during relocating or repairing the unit, be sure that the unit is running in cooling mode. Then, fully close the valve at high pressure side (liquid valve). About 30-40 seconds later, fully close the valve at low pressure side (gas valve), immediately stop the unit and disconnect power. Please note that the time for refrigerant recovery should not exceed 1 minute.

If refrigerant recovery takes too much time, air may be sucked in and cause pressure rise or compressor rupture, resulting in injury.

4. During refrigerant recovery, make sure that liquid valve and gas valve are fully closed and power is disconnected before detaching the connection pipe.

If compressor starts running when stop valve is open and connection pipe is not yet connected, air will be sucked in and cause pressure rise or compressor rupture, resulting in injury.

5. When installing the unit, make sure that connection pipe is securely connected before the compressor starts running.

If compressor starts running when stop valve is open and connection pipe is not yet connected, air will be sucked in and cause pressure rise or compressor rupture, resulting in injury.

6. Prohibit installing the unit at the place where there may be leaked corrosive gas or flammable gas.

If there leaked gas around the unit, it may cause explosion and other accidents.

7. Do not use extension cords for electrical connections. If the electric wire is not long enough, please contact a local service center authorized and ask for a proper electric wire.

Poor connections may lead to electric shock or fire.

8. Use the specified types of wires for electrical connections between the indoor and outdoor units. Firmly clamp the wires so that their terminals receive no external stresses.

Electric wires with insufficient capacity, wrong wire connections and insecure wire terminals may cause electric shock or fire.

Safety Precautions for Refrigerant

● To realize the function of the air conditioner unit, a special refrigerant circulates in the system. The used refrigerant is the fluoride R32, which is specially cleaned. The refrigerant is flammable and inodorous. Furthermore, it can lead to explosion under certain conditions. But the flammability of the refrigerant is very low. It can be ignited only by fire.

● Compared to common refrigerants, R32 is a nonpolluting refrigerant with no harm to the ozoneosphere. The influence upon the greenhouse effect is also lower. R32 has got very good thermodynamic features which lead to a really high energy efficiency. The units therefore need a less filling.

WARNING:

● Do not use means to accelerate the defrosting process or to clean, other than those recommended by the manufacture.

Should repair be necessary, contact your nearest authorized Service Centre. Any repairs carried out by unqualified personnel may be dangerous. The appliance shall be stored in a room without continuously operating ignition sources. (for example: open flames, an operating gas appliance or an operating electric heater.)

● Do not pierce or burn.

● Appliance shall be installed, operated and stored in a room with a floor area larger than "X" m² (see table a). (only applies to appliances that are not fixed appliances).

● Appliance filled with flammable gas R32. For repairs, strictly follow manufacturers instructions only. Be aware that refrigerants not contain odour.

● Read specialists manual.

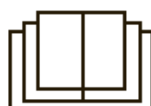

Safety Operation of Flammable Refrigerant

Qualification requirement for installation and maintenance man

- All the work men who are engaging in the refrigeration system should bear the valid certification awarded by the authoritative organization and the qualification for dealing with the refrigeration system recognized by this industry. If it needs other technician to maintain and repair the appliance, they should be supervised by the person who bears the qualification for using the flammable refrigerant.
- It can only be repaired by the method suggested by the equipments manufacturer.

Installation notes

- The air conditioner is not allowed to use in a room that has running fire (such as fire source,working coal gas ware, operating heater).
- It is not allowed to drill hole or burn the connection pipe.
- The air conditioner must be installed in a room that is larger than the minimum room area. The minimum room area is shown on the nameplate or following table a.
- Leak test is a must after installation.

table a - Minimum room area(m²)

Minimum room area(m ²)	Charge amount (kg)	≤1.2	1.3	1.4	1.5	1.6	1.7	1.8	1.9	2	2.1	2.2	2.3	2.4	2.5
	floor location	4	14.5	16.8	19.3	22	24.8	27.8	31	34.3	37.8	41.5	45.4	49.4	53.6
window mounted	4	5.2	6.1	7	7.9	8.9	10	11.2	12.4	13.6	15	16.3	17.8	19.3	
wall mounted	4	4	4	4	4	4	4	4	4	4.2	4.6	5	5.5	6	
ceiling mounted	4	4	4	4	4	4	4	4	4	4	4	4	4	4	4

Maintenance notes

- Check whether the maintenance area or the room area meet the requirement of the nameplate.
 - Its only allowed to be operated in the rooms that meet the requirement of the nameplate.
- Check whether the maintenance area is well-ventilated.
 - The continuous ventilation status should be kept during the operation process.
- Check whether there is fire source or potential fire source in the maintenance area.
 - The naked flame is prohibited in the maintenance area; and the “no smoking” warning board should be hanged.
- Check whether the appliance mark is in good condition.
 - Replace the vague or damaged warning mark.

Welding

- If you should cut or weld the refrigerant system pipes in the process of maintaining, please follow the steps as below:
 - a. Shut down the unit and cut power supply
 - b. Eliminate the refrigerant
 - c. Vacuuming
 - d. Clean it with N₂ gas
 - e. Cutting or welding
 - f. Carry back to the service spot for welding
- Make sure that there isnt any naked flame near the outlet of the vacuum pump and its well-ventilated.
- The refrigerant should be recycled into the specialized storage tank.

Filling the refrigerant

- Use the refrigerant filling appliances specialized for R32. Make sure that different kinds of refrigerant wont contaminate with each other.
- The refrigerant tank should be kept upright at the time of filling refrigerant.
- Stick the label on the system after filling is finished (or havent finished).
- Dont overfilling.
- After filling is finished, please do the leakage detection before test running; another time of leak detection should be done when its removed.

Safety instructions for transportation and storage

- Please use the flammable gas detector to check before unload and open the container.
- No fire source and smoking.
- According to the local rules and laws.

Main Tools for Installation and Maintenance

<p>1. Level meter, measuring tape</p> 	<p>2. Screw driver</p> 	<p>3. Impact drill, drill head, electric drill</p> 
<p>4. Electroprobe</p> 	<p>5. Universal meter</p> 	<p>6. Torque wrench, open-end wrench, inner hexagon spanner</p> 
<p>7. Electronic leakage detector</p> 	<p>8. Vacuum pump</p> 	<p>9. Pressure meter</p> 
<p>10. Pipe pliers, pipe cutter</p> 	<p>11. Pipe expander, pipe bender</p> 	<p>12. Soldering appliance, refrigerant container electronic scale</p> 

8. Installation

8.1 Installation Dimension Diagram

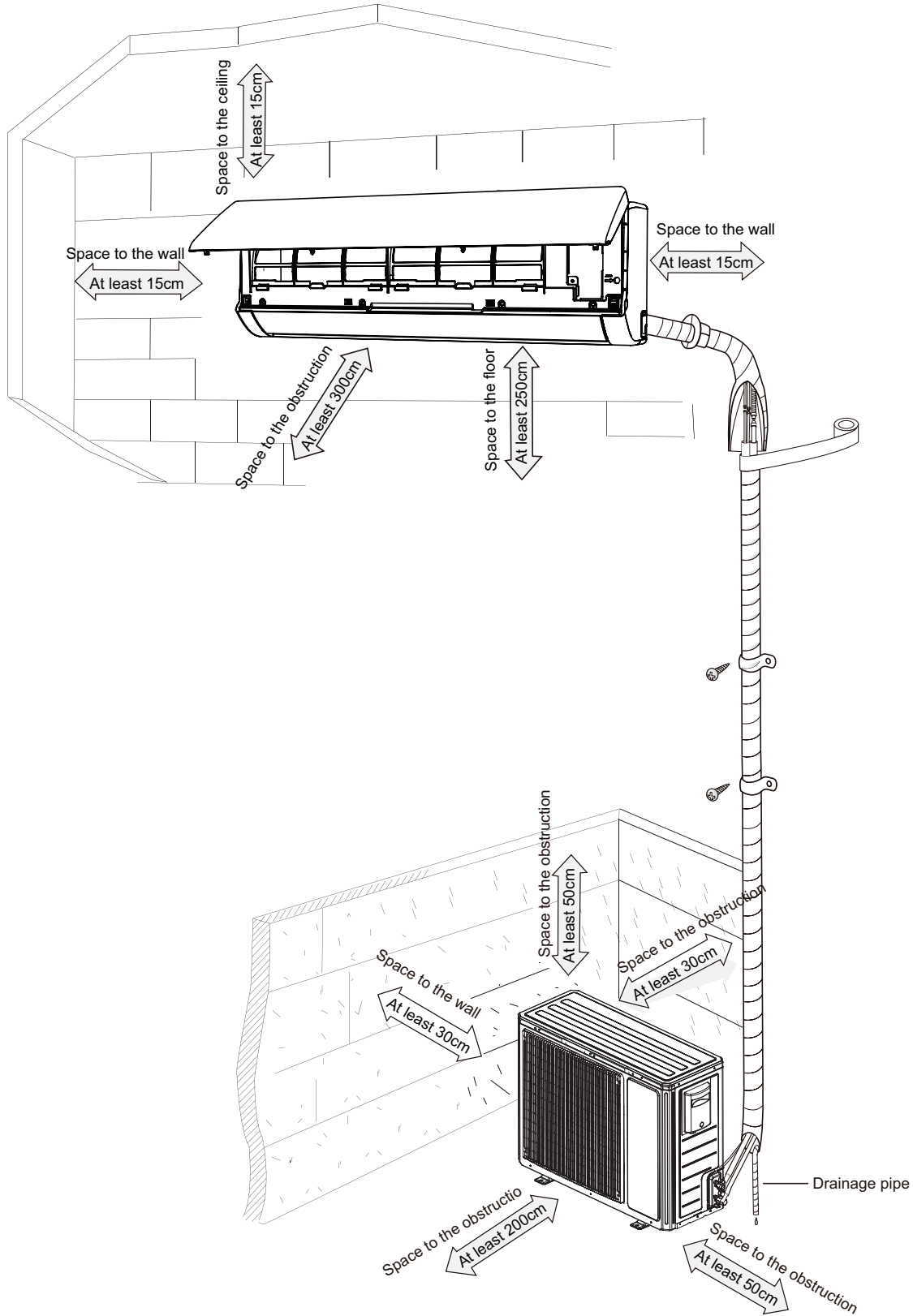

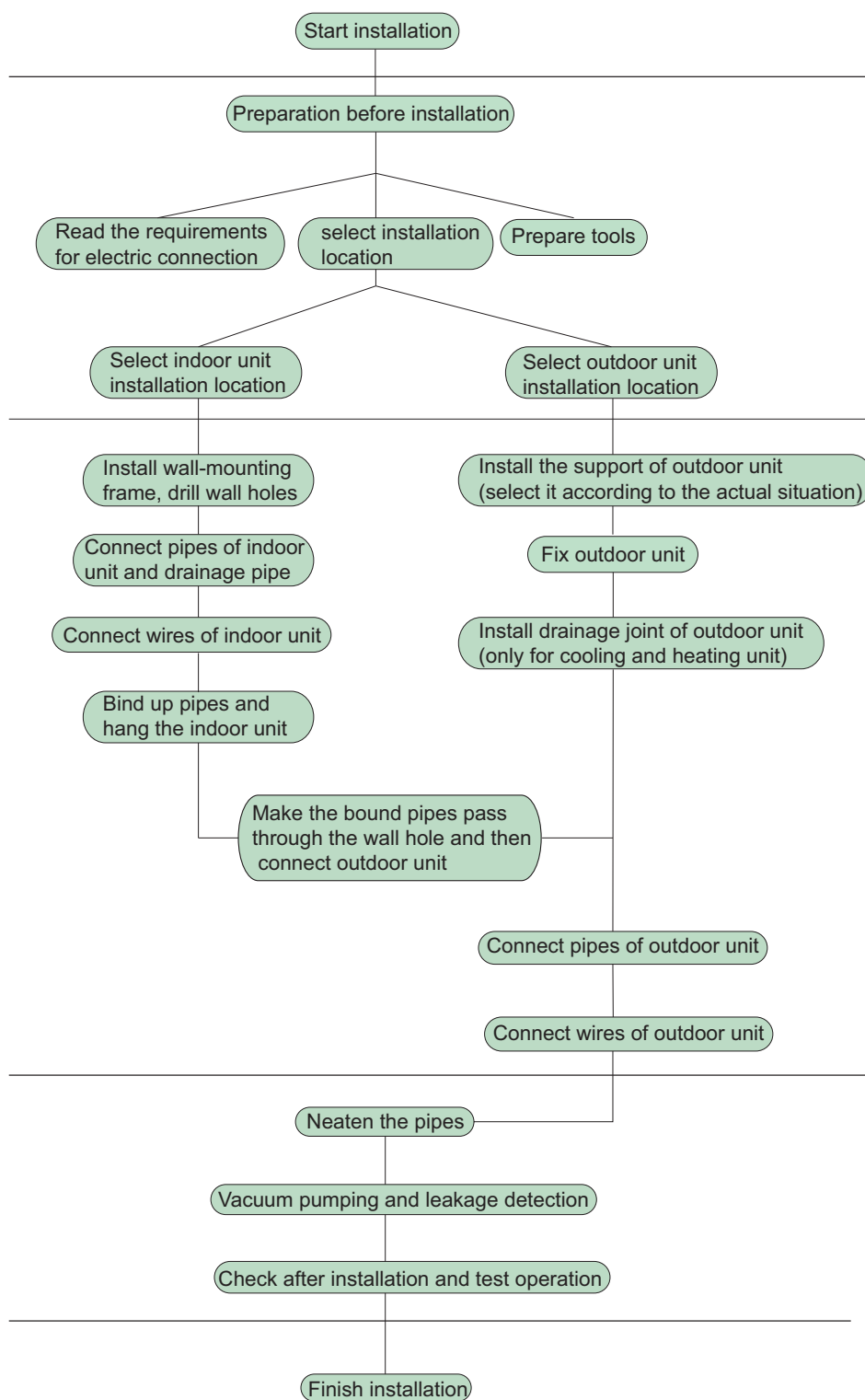

Note: this flow is only for reference; please find the more detailed installation steps in this section.

8.2 Installation Parts-checking

No.	Name	No.	Name
1	Indoor unit	8	Sealing gum
2	Outdoor unit	9	Wrapping tape
3	Connection pipe	10	Support of outdoor unit
4	Drainage pipe	11	Fixing screw
5	Wall-mounting frame	12	Drainage plug(cooling and heating unit)
6	Connecting cable(power cord)	13	Owners manual, remote controller
7	Wall pipe		

⚠ Note:

- 1.Please contact the local agent for installation.
- 2.Dont use unqualified power cord.

8.3 Selection of Installation Location

1. Basic Requirement:

Installing the unit in the following places may cause malfunction. If it is unavoidable, please consult the local dealer:

- (1) The place with strong heat sources, vapors, flammable or explosive gas, or volatile objects spread in the air.
- (2) The place with high-frequency devices (such as welding machine, medical equipment).
- (3) The place near coast area.
- (4) The place with oil or fumes in the air.
- (5) The place with sulfureted gas.
- (6) Other places with special circumstances.
- (7) The appliance shall not be installed in the laundry.
- (8) Its not allowed to be installed on the unstable or motive base structure(such as truck) or in the corrosive environment (such as chemical factory).

2. Indoor Unit:

- (1) There should be no obstruction near air inlet and air outlet.
- (2) Select a location where the condensation water can be dispersed easily and wont affect other people.
- (3) Select a location which is convenient to connect the outdoor unit and near the power socket.
- (4) Select a location which is out of reach for children.
- (5) The location should be able to withstand the weight of indoor unit and wont increase noise and vibration.
- (6) The appliance must be installed 2.5m above floor.
- (7) Dont install the indoor unit right above the electric appliance.
- (8) Please try your best to keep way from fluorescent lamp.

3. Outdoor Unit:

- (1) Select a location where the noise and outflow air emitted by the outdoor unit will not affect neighborhood.
- (2) The location should be well ventilated and dry, in which the outdoor unit wont be exposed directly to sunlight or strong wind.
- (3) The location should be able to withstand the weight of outdoor unit.
- (4) Make sure that the installation follows the requirement of installation dimension diagram.
- (5) Select a location which is out of reach for children and far away from animals or plants.If it is unavoidable, please add fence for safety purpose.

8.4 Requirements for electric connection

1. Safety Precaution

- (1) Must follow the electric safety regulations when installing the unit.
- (2) According to the local safety regulations, use qualified power supply circuit and air switch.
- (3) Make sure the power supply matches with the requirement of air conditioner. Unstable power supply or incorrect wiring may result in electric shock,fire hazard or malfunction. Please install proper power supply cables before using the air conditioner.

Air-conditioner	Air switch capacity
09K	10A
12/18/24K	16A

- (4) Properly connect the live wire, neutral wire and grounding wire of power socket.
- (5) Be sure to cut off the power supply before proceeding any work related to electricity and safety.
- (6) Do not put through the power before finishing installation.
- (7) If the supply cord is damaged, it must be replaced by the manufacturer, its service agent or similarly qualified persons in order to avoid a hazard.
- (8) The temperature of refrigerant circuit will be high, please keep the interconnection cable away from the copper tube.
- (9) The appliance shall be installed in accordance with national wiring regulations.
- (10) Appliance shall be installed, operated and stored in a room with a floor area larger than "X"m (see table a).



Please notice that the unit is filled with flammable gas R32. Inappropriate treatment of the unit involves the risk of severe damages of people and material. Details to this refrigerant are found in chapter "refrigerant".

2. Grounding Requirement:

- (1) The air conditioner is first class electric appliance. It must be properly grounding with specialized grounding device by a professional. Please make sure it is always grounded effectively, otherwise it may cause electric shock.
- (2) The yellow-green wire in air conditioner is grounding wire, which cant be used for other purposes.
- (3) The grounding resistance should comply with national electric safety regulations.
- (4) The appliance must be positioned so that the plug is accessible.
- (5) An all-pole disconnection switch having a contact separation of at least 3mm in all poles should be connected in fixed wiring.
- (6) Including an air switch with suitable capacity, please note the following table. Air switch should be included magnet buckle and heating buckle function, it can protect the circuit-short and overload. (Caution: please do not use the fuse only for protect the circuit)

8.5 Installation of Indoor Unit

1. Choosing Installation location

Recommend the installation location to the client and then confirm it with the client.

2. Install Wall-mounting Frame

(1) Hang the wall-mounting frame on the wall; adjust it in horizontal position with the level meter and then point out the screw fixing holes on the wall.

(2) Drill the screw fixing holes on the wall with impact drill (the specification of drill head should be the same as the plastic expansion particle) and then fill the plastic expansion particles in the holes.

(3) Fix the wall-mounting frame on the wall with tapping screws and then check if the frame is firmly installed by pulling the frame. If the plastic expansion particle is loose, please drill another fixing hole nearby.

3. Install Wall-mounting Frame

(1) Choose the position of piping hole according to the direction of outlet pipe. The position of piping hole should be a little lower than the wall-mounted frame.(As show in Fig.1)

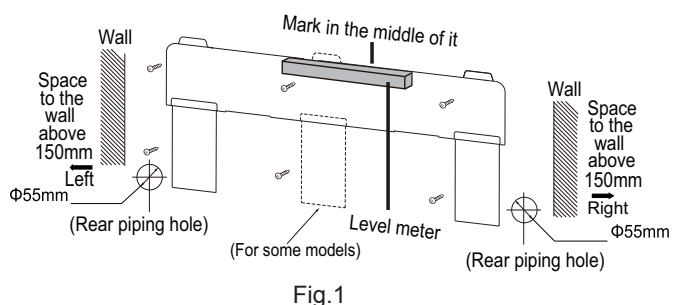

(2) Open a piping hole with the diameter of $\Phi 55/70\text{mm}$ on the selected outlet pipe position. In order to drain smoothly, slant the piping hole on the wall slightly downward to the outdoor side with the gradient of $5-10^\circ$.(As show in Fig.2)

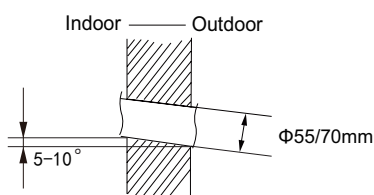

Fig.2

⚠ Note:

(1) Pay attention to dust prevention and take relevant safety measures when opening the hole.

4. Outlet pipe

(1) The pipe can be led out in the direction of right, rear right, left or rear left.(As show in Fig.3)

(2) When selecting leading out the pipe from left or right, please cut off the corresponding hole on the bottom case.(As show in Fig.4)

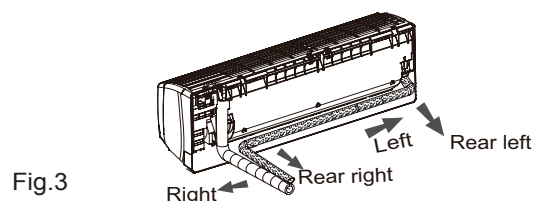

Fig.3

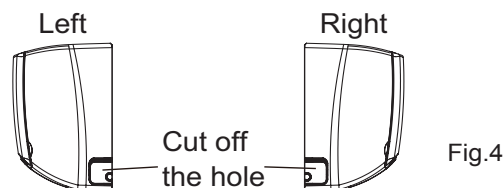

Fig.4

5. Connect the Pipe of Indoor Unit

(1) Aim the pipe joint at the corresponding bellmouth.(As show in Fig.5)

(2) Pretightening the union nut with hand.

(3) Adjust the torque force by referring to the following sheet. Place the open-end wrench on the pipe joint and place the torque wrench on the union nut. Tighten the union nut with torque wrench.(As show in Fig.6)

(4) Wrap the indoor pipe and joint of connection pipe with insulating pipe, and then wrap it with tape.(As show in Fig.7)

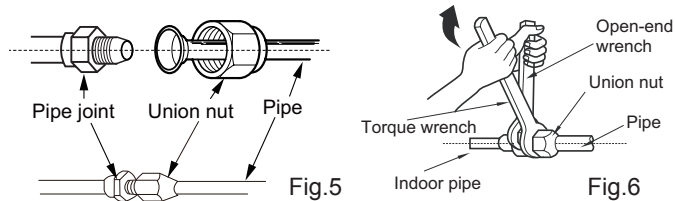

Fig.5

Fig.6

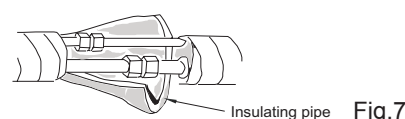

Fig.7

Refer to the following table for wrench moment of force:

Piping size	Tightening torque(N.m)
$\Phi 1/4$	15~20
$\Phi 3/8$	30~40
$\Phi 1/2$	45~55
$\Phi 5/8$	60~65
$\Phi 3/4$	70~75

6. Install Drain Hose

(1) Connect the drain hose to the outlet pipe of indoor unit.(As show in Fig.8)

(2) Bind the joint with tape.(As show in Fig.9)

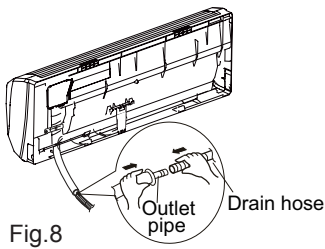

Fig.8

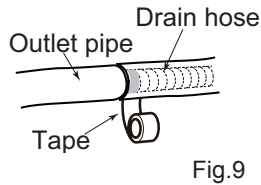

Fig.9

⚠ Note:

- (1) Add insulating pipe in the indoor drain hose in order to prevent condensation.
- (2) The plastic expansion particles are not provided. (As show in Fig.10)

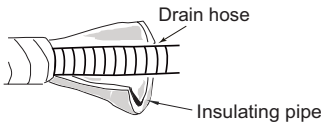

Fig.10

7. Connect Wire of Indoor Unit

- (1) Open the panel, remove the screw on the wiring cover and then take down the cover.(As show in Fig.11)

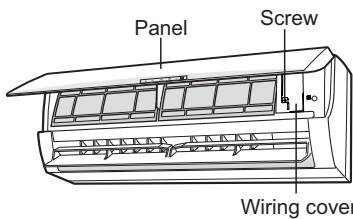

Fig.11

- (2) Make the power connection wire go through the cable-cross hole at the back of indoor unit and then pull it out from the front side.(As show in Fig.12)

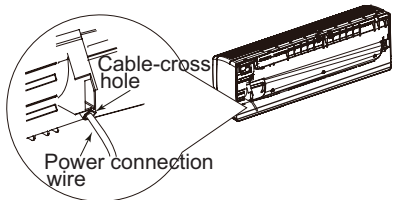
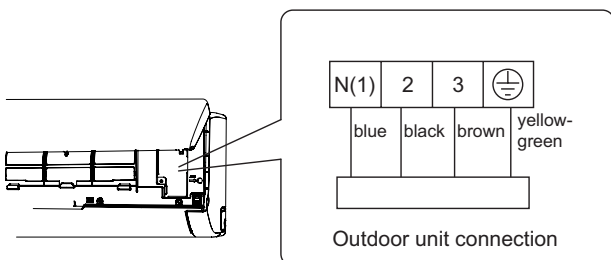

Fig.12

- (3) Remove the wire clip; connect the power connection wire to the wiring terminal according to the color; tighten the screw and then fix the power connection wire with wire clip.(As show in Fig.13)



Note: the wiring board is for reference only, please refer to the actual one.

Fig.13

- (4) Put wiring cover back and then tighten the screw.
- (5) Close the panel.

⚠ Note:

- (1) All wires of indoor unit and outdoor unit should be connected by a professional.
- (2) If the length of power connection wire is insufficient, please contact the supplier for a new one. Avoid extending the wire by yourself.
- (3) For the air conditioner with plug, the plug should be reachable after finishing installation.
- (4) For the air conditioner without plug, an air switch must be installed in the line. The air switch should be all-pole parting and the contact parting distance should be more than 3mm.

8. Bind up Pipe

- (1) Bind up the connection pipe, power cord and drain hose with the band.(As show in Fig.14)
- (2) Reserve a certain length of drain hose and power cord for installation when binding them. When binding to a certain degree, separate the indoor power and then separate the drain hose.(As show in Fig.15)
- (3) Bind them evenly.
- (4) The liquid pipe and gas pipe should be bound separately at the end.

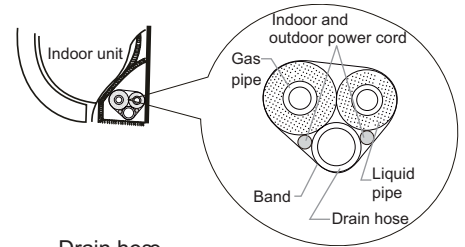

Fig.14

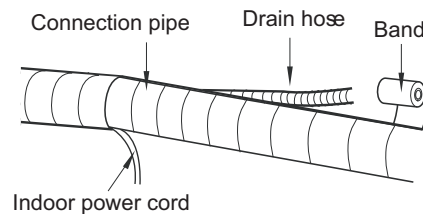

Fig.15

⚠ Note:

- (1) The power cord and control wire cant be crossed or winding.
- (2) The drain hose should be bound at the bottom.

9. Hang the Indoor Unit

- (1) Put the bound pipes in the wall pipe and then make them pass through the wall hole.
- (2) Hang the indoor unit on the wall-mounting frame.
- (3) Stuff the gap between pipes and wall hole with sealing gum.
- (4) Fix the wall pipe.(As show in Fig.16)
- (5) Check if the indoor unit is installed firmly and closed to the wall.(As show in Fig.17)

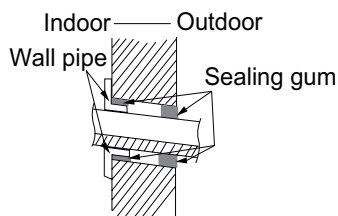

Fig.16

⚠ Note:

Do not bend the drain hose too excessively in order to prevent blocking.

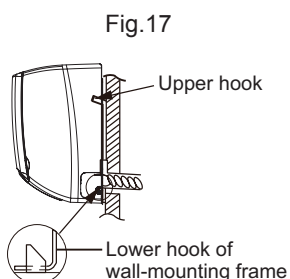

Fig.17

8.6 Installation of Outdoor Unit

1. Fix the Support of Outdoor Unit(Select it according to the actual installation situation)

- (1) Select installation location according to the house structure.
- (2) Fix the support of outdoor unit on the selected location with expansion screws.

⚠ Note:

- (1) Take sufficient protective measures when installing the outdoor unit.
- (2) Make sure the support can withstand at least four times the unit weight.
- (3) The outdoor unit should be installed at least 3cm above the floor in order to install drain joint.(As show in Fig.18)
- (4) For the unit with cooling capacity of 2300W~5000W, 6 expansion screws are needed; for the unit with cooling capacity of 6000W~8000W, 8 expansion screws are needed; for the unit with cooling capacity of 10000W~16000W, 10 expansion screws are needed.

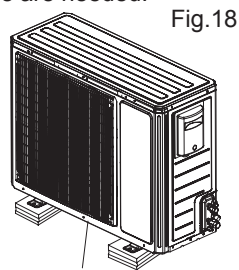

Fig.18

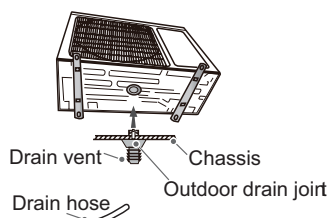

Fig.19

2. Install Drain Joint(Only for cooling and heating unit)

- (1) Connect the outdoor drain joint into the hole on the chassis.
- (2) Connect the drain hose into the drain vent.
(As show in Fig.19)

3. Fix Outdoor Unit

- (1) Place the outdoor unit on the support.
- (2) Fix the foot holes of outdoor unit with bolts.
(As show in Fig.20)

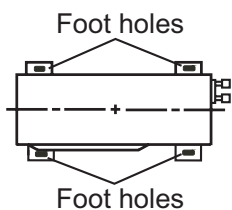

Fig.20

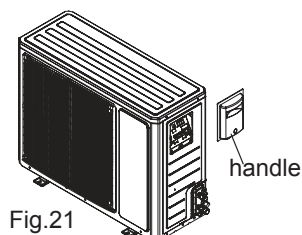

Fig.21

4. Connect Indoor and Outdoor Pipes

- (1) Remove the screw on the right handle of outdoor unit and then remove the handle.(As show in Fig.21)
- (2) Remove the screw cap of valve and aim the pipe joint at the bellmouth of pipe.(As show in Fig.22)

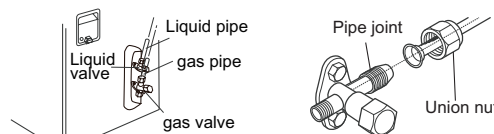

Fig.22

- (3) Pretightening the union nut with hand.
- (4) Tighten the union nut with torque wrench .

Refer to the following table for wrench moment of force:

Piping size	Tightening torque(N·m)
Φ1/4	15~20
Φ3/8	30~40
Φ1/2	45~55
Φ5/8	60~65
Φ3/4	70~75

5. Connect Outdoor Electric Wire

- (1) Remove the wire clip; connect the power connection wire and signal control wire (only for cooling and heating unit) to the wiring terminal according to the color; fix them with screws.(As show in Fig.23)

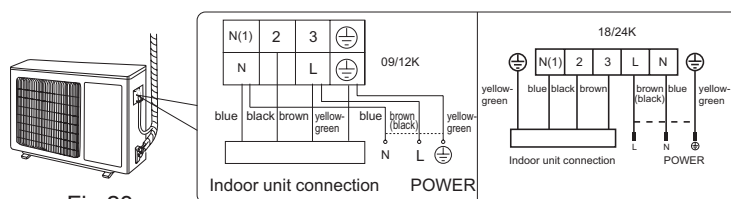

Fig.23

Note: the wiring board is for reference only, please refer to the actual one.

- (2) Fix the power connection wire and signal control wire with wire clip (only for cooling and heating unit).

⚠ Note:

- (1) After tightening the screw, pull the power cord slightly to check if it is firm.
- (2) Never cut the power connection wire to prolong or shorten the distance.

6. Neaten the Pipes

- (1) The pipes should be placed along the wall, bent reasonably and hidden possibly. Min. semidiameter of bending the pipe is 10cm.
- (2) If the outdoor unit is higher than the wall hole, you must set a U-shaped curve in the pipe before pipe goes into the room, in order to prevent rain from getting into the room.(As show in Fig.24)

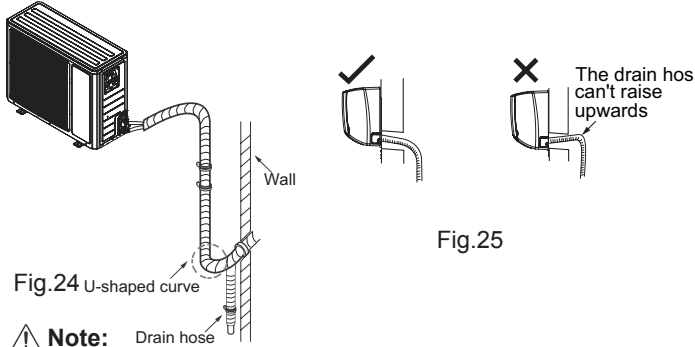

Fig.25

Note: Drain hose

- (1) The through-wall height of drain hose shouldnt be higher than the outlet pipe hole of indoor unit.(As show in Fig.25)
- (2) Slant the drain hose slightly downwards. The drain hose cant be curved, raised and fluctuant, etc.(As show in Fig.26)
- (3) The water outlet cant be placed in water in order to drain smoothly.(As show in Fig.27)

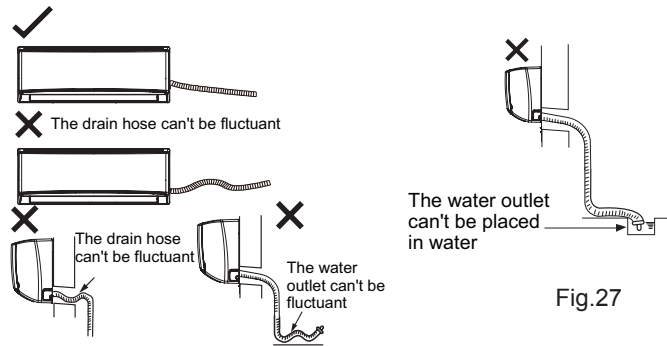

Fig.26

Fig.27

8.7 Vacuum Pumping and Leak Detection

1. Use Vacuum Pump

- (1) Remove the valve caps on the liquid valve and gas valve and the nut of refrigerant charging vent.
- (2) Connect the charging hose of piezometer to the refrigerant charging vent of gas valve and then connect the other charging hose to the vacuum pump.
- (3) Open the piezometer completely and operate for 10-15min to check if the pressure of piezometer remains in -0.1MPa .
- (4) Close the vacuum pump and maintain this status for 1-2min to check if the pressure of piezometer remains in -0.1MPa . If the pressure decreases, there may be leakage.
- (5) Remove the piezometer, open the valve core of liquid valve and gas valve completely with inner hexagon spanner.
- (6) Tighten the screw caps of valves and refrigerant charging vent.(As show in Fig.28)

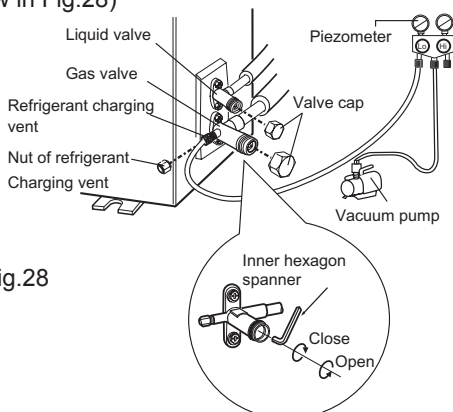

Fig.28

2. Leakage Detection

- (1) With leakage detector: Check if there is leakage with leakage detector.
- (2) With soap water:

If leakage detector is not available, please use soap water for leakage detection. Apply soap water at the suspected position and keep the soap water for more than 3min. If there are air bubbles coming out of this position, theres a leakage.

8.8 Check after Installation and Test Operation

1. Check after Installation

Check according to the following requirement after finishing installation.

NO.	Items to be checked	Possible malfunction
1	Has the unit been installed firmly?	The unit may drop, shake or emit noise.
2	Have you done the refrigerant leakage test?	It may cause insufficient cooling (heating) capacity.
3	Is heat insulation of pipeline sufficient?	It may cause condensation and water dripping.
4	Is water drained well?	It may cause condensation and water dripping.
5	Is the voltage of power supply according to the voltage marked on the nameplate?	It may cause malfunction or damage the parts.
6	Is electric wiring and pipeline installed correctly?	It may cause malfunction or damage the parts.
7	Is the unit grounded securely?	It may cause electric leakage.
8	Does the power cord follow the specification?	It may cause malfunction or damage the parts.
9	Is there any obstruction in air inlet and air outlet?	It may cause insufficient cooling (heating) capacity.
10	The dust and sundries caused during installation are removed?	It may cause malfunction or damaging the parts.
11	The gas valve and liquid valve of connection pipe are open completely?	It may cause insufficient cooling (heating) capacity.
12	Is the inlet and outlet of piping hole been covered?	It may cause insufficient cooling (heating) capacity or waster eletricity.

2. Test Operation

- (1) Preparation of test operation
 - The client approves the air conditioner installation.
 - Specify the important notes for air conditioner to the client.
- (2) Method of test operation
 - Put through the power, press ON/OFF button on the remote controller to start operation.
 - Press MODE button to select AUTO, COOL, DRY, FAN and HEAT to check whether the operation is normal or not.
 - If the ambient temperature is lower than 16°C , the air conditioner cant start cooling.

9. Maintenance

9.1 Error Code List

NO.	Malfunction Name	Display Method of Indoor Unit	A/C status	Possible Causes
		Dual-8 Code Display		
1	High pressure protection of system	E1	During cooling and drying operation, except indoor fan operates, all loads stop operation. During heating operation, the complete unit stops.	Possible reasons: 1. Refrigerant was superabundant; 2. Poor heat exchange (including filth blockage of heat exchanger and bad radiating environment); Ambient temperature is too high.
2	In defect of refrigerant	F0	The Dual-8 Code Display will show F0 and the complete unit stops.	1. In defect of refrigerant; 2. Indoor evaporator temperature sensor works abnormally; 3. The unit has been plugged up somewhere.
3	High discharge temperature protection of compressor	E4	During cooling and drying operation, compressor and outdoor fan stop while indoor fan operates. During heating operation, all loads stop.	Please refer to the malfunction analysis (discharge protection, overload).
4	Overcurrent protection	E5	During cooling and drying operation, compressor and outdoor fan stop while indoor fan operates. During heating operation, all loads stop.	1. Supply voltage is unstable; 2. Supply voltage is too low and load is too high; 3. Evaporator is dirty.
5	Communication Malfunction	E6	During cooling operation, compressor stops while indoor fan motor operates. During heating operation, the complete unit stops.	Refer to the corresponding malfunction analysis.
6	High temperature resistant protection	E8	During cooling operation: compressor will stop while indoor fan will operate. During heating operation, the complete unit stops.	Refer to the malfunction analysis (overload, high temperature resistant).
7	EEPROM malfunction	EE	During cooling and drying operation, compressor will stop while indoor fan will operate; During heating operation, the complete unit will stop	Replace outdoor control panel AP1
8	Limit/ decrease frequency due to high temperature of module	EU	All loads operate normally, while operation frequency for compressor is decreased	Discharging after the complete unit is de-energized for 20mins, check whether the thermal grease on IPM Module of outdoor control panel AP1 is sufficient and whether the radiator is inserted tightly. If its no use, please replace control panel AP1.
9	Malfunction protection of jumper cap	C5	Wireless remote receiver and button are effective, but can not dispose the related command	1. No jumper cap insert on mainboard. 2. Incorrect insert of jumper cap. 3. Jumper cap damaged. 4. Abnormal detecting circuit of mainboard.

NO.	Malfunction Name	Display Method of Indoor Unit	A/C status	Possible Causes
		Dual-8 Code Display		
10	Indoor ambient temperature sensor is open/short circuited	F1	During cooling and drying operation, indoor unit operates while other loads will stop; during heating operation, the complete unit will stop operation.	<ol style="list-style-type: none"> 1. Loosening or bad contact of indoor ambient temp. sensor and mainboard terminal. 2. Components in mainboard fell down leads short circuit. 3. Indoor ambient temp. sensor damaged.(check with sensor resistance value chart) 4. Mainboard damaged.
11	Indoor evaporator temperature sensor is open/short circuited	F2	AC stops operation once reaches the setting temperature. Cooling, drying: internal fan motor stops operation while other loads stop operation; heating: AC stop operation	<ol style="list-style-type: none"> 1. Loosening or bad contact of Indoor evaporator temp. sensor and mainboard terminal. 2. Components on the mainboard fall down leads short circuit. 3. Indoor evaporator temp. sensor damaged.(check temp. sensor value chart for testing) 4. Mainboard damaged.
12	Outdoor ambient temperature sensor is open/short circuited	F3	During cooling and drying operating, compressor stops while indoor fan operates; During heating operation, the complete unit will stop operation	Outdoor temperature sensor hasnt been connected well or is damaged. Please check it by referring to the resistance table for temperature sensor)
13	Outdoor condenser temperature sensor is open/short circuited	F4	During cooling and drying operation, compressor stops while indoor fan will operate; During heating operation, the complete unit will stop operation.	Outdoor temperature sensor hasnt been connected well or is damaged. Please check it by referring to the resistance table for temperature sensor)
14	Outdoor discharge temperature sensor is open/short circuited	F5	During cooling and drying operation, compressor will sop after operating for about 3 mins, while indoor fan will operate; During heating operation, the complete unit will stop after operating for about 3 mins.	<ol style="list-style-type: none"> 1.Outdoor temperature sensor hasnt been connected well or is damaged. Please check it by referring to the resistance table for temperature sensor) 2.The head of temperature sensor hasnt been inserted into the copper tube
15	Limit/ decrease frequency due to overload	F6	All loads operate normally, while operation frequency for compressor is decreased	Refer to the malfunction analysis (overload, high temperature resistant)
16	Decrease frequency due to overcurrent	F8	All loads operate normally, while operation frequency for compressor is decreased	The input supply voltage is too low; System pressure is too high and overload

NO.	Malfunction Name	Display Method of Indoor Unit	A/C status	Possible Causes
		Dual-8 Code Display		
17	Decrease frequency due to high air discharge	F9	All loads operate normally, while operation frequency for compressor is decreased	Overload or temperature is too high; Refrigerant is insufficient; Malfunction of electric expansion valve (EKV)
18	Limit/decrease frequency due to antifreezing	FH	All loads operate normally, while operation frequency for compressor is decreased	Poor air-return in indoor unit or fan speed is too low
19	Voltage for DC bus-bar is too high	PH	During cooling and drying operation, compressor will stop while indoor fan will operate; During heating operation, the complete unit will stop operation.	1. Measure the voltage of position L and N on wiring board (XT), if the voltage is higher than 265VAC, turn on the unit after the supply voltage is increased to the normal range. 2.If the AC input is normal, measure the voltage of electrolytic capacitor C on control panel (AP1), if its normal, theres malfunction for the circuit, please replace the control panel (AP1)
20	Voltage of DC bus-bar is too low	PL	During cooling and drying operation, compressor will stop while indoor fan will operate; During heating operation, the complete unit will stop	1. Measure the voltage of position L and N on wiring board (XT), if the voltage is higher than 150VAC, turn on the unit after the supply voltage is increased to the normal range. 2.If the AC input is normal, measure the voltage of electrolytic capacitor C on control panel (AP1), if its normal, theres malfunction for the circuit, please replace the control panel (AP1)
21	Compressor Min frequency in test state	P0		Showing during min. cooling or min. heating test
22	Compressor rated frequency in test state	P1		Showing during nominal cooling or nominal heating test
23	Compressor maximum frequency in test state	P2		Showing during max. cooling or max. heating test

NO.	Malfunction Name	Display Method of Indoor Unit	A/C status	Possible Causes
		Dual-8 Code Display		
24	Compressor intermediate frequency in test state	P3		Showing during middle cooling or middle heating test
25	Overcurrent protection of phase current for compressor	P5	During cooling and drying operation, compressor will stop while indoor fan will operate; During heating operation, the complete unit will stop operation.	Refer to the malfunction analysis (IPM protection, loss of synchronism protection and overcurrent protection of phase current for compressor.
26	Charging malfunction of capacitor	PU	During cooling and drying operation, compressor will stop while indoor fan will operate; During heating operation, the complete unit will stop	Refer to the part three—charging malfunction analysis of capacitor
27	Malfunction of module temperature sensor circuit	P7	During cooling and drying operation, compressor will stop while indoor fan will operate; During heating operation, the complete unit will stop	Replace outdoor control panel AP1
28	Module high temperature protection	P8	During cooling operation, compressor will stop while indoor fan will operate; During heating operation, the complete unit will stop	After the complete unit is de-energized for 20mins, check whether the thermal grease on IPM Module of outdoor control panel AP1 is sufficient and whether the radiator is inserted tightly. If its no use, please replace control panel AP1.
29	Overload protection for compressor	H3	During cooling and drying operation, compressor will stop while indoor fan will operate; During heating operation, the complete unit will stop operation.	1. Wiring terminal OVC-COMP is loosened. In normal state, the resistance for this terminal should be less than 1ohm. 2.Refer to the malfunction analysis (discharge protection, overload)
30	IPM protection	H5	During cooling and drying operation, compressor will stop while indoor fan will operate; During heating operation, the complete unit will stop operation.	Refer to the malfunction analysis (IPM protection, loss of synchronism protection and overcurrent protection of phase current for compressor.
31	Malfunction of zero-cross detection circuit	U8	The complete unit stops	1.Power supply is abnormal; 2.Detection circuit of indoor control mainboard is abnormal.

NO.	Malfunction Name	Display Method of Indoor Unit	A/C status	Possible Causes
		Dual-8 Code Display		
32	Internal motor (fan motor) do not operate	H6	Internal fan motor, external fan motor, compressor and electric heater stop operation,guide louver stops at present location.	<ol style="list-style-type: none"> 1. Bad contact of DC motor feedback terminal. 2. Bad contact of DC motor control end. 3. Fan motor is stalling. 4. Motor malfunction. 5. Malfunction of mainboard rev detecting circuit.
33	Desynchronizing of compressor	H7	During cooling and drying operation, compressor will stop while indoor fan will operate; During heating operation, the complete unit will stop operation.	Refer to the malfunction analysis (IPM protection, loss of synchronism protection and overcurrent protection of phase current for compressor.
34	Outdoor DC fan motor malfunction	L3	Outdoor DC fan motor malfunction lead to compressor stop operation,	DC fan motor malfunction or system blocked or the connector loosed
35	power protection	L9	compressor stop operation and Outdoor fan motor will stop 30s latter , 3 minutes latter fan motor and compressor will restart	To protect the electrical components when detect high power
36	Indoor unit and outdoor unit doesnt match	LP	compressor and Outdoor fan motor cant work	Indoor unit and outdoor unit doesnt match
37	Failure start-up	LC	During cooling and drying operation, compressor will stop while indoor fan will operate; During heating operation, the complete unit will stop operation.	Refer to the malfunction analysis
38	Defrosting	Heating indicator off for 0.5s and then blinks for 10s	Not the error code. Its the status code for the operation	
39	Malfunction of phase current detection circuit for compressor	U1	During cooling and drying operation, compressor will stop while indoor fan will operate; During heating operation, the complete unit will stop	Replace outdoor control panel AP1
40	Malfunction of voltage dropping for DC bus-bar	U3	During cooling and drying operation, compressor will stop while indoor fan will operate; During heating operation, the complete unit will stop	Supply voltage is unstable

NO.	Malfunction Name	Display Method of Indoor Unit	A/C status	Possible Causes
		Dual-8 Code Display		
41	Malfunction of complete units current detection	U5	During cooling and drying operation, the compressor will stop while indoor fan will operate; During heating operating, the complete unit will stop operation.	Theres circuit malfunction on outdoor units control panel AP1, please replace the outdoor units control panel AP1.
42	The four-way valve is abnormal	U7	If this malfunction occurs during heating operation, the complete unit will stop operation.	1. Supply voltage is lower than AC175V; 2. Wiring terminal 4V is loosened or broken; 3. 4V is damaged, please replace 4V.
43	Undefined outdoor unit error	oE	Cool: compressor and outdoor fan stops operation, while indoor fan operates; Heat: compressor, outdoor fan and indoor fan stop operation.	1. Outdoor ambient temperature exceeds the operation range of unit (eg: less than -20oC or more than 60oC for cooling; more than 30oC for heating); 2. Failure startup of compressor? 3. Are wires of compressor not connected tightly? 4. Is compressor damaged? 5. Is main board damaged?
44	Anti-freezing protection for evaporator	E2	Not the error code. Its the status code for the operation.	
45	Cold air prevention protection	E9	Not the error code. Its the status code for the operation.	
46	Refrigerant recovery mode	Fo	Refrigerant recovery. The Serviceman operates it for maintenance	
47	Malfunction of detecting plate(WIFI)	JF	Loads operate normally, while the unit cant be normally controlled by APP.	1. Main board of indoor unit is damaged; 2. Detection board is damaged; 3. The connection between indoor unit and detection board is not good;
48	PFC protection	HC	During cooling and drying operation, compressor will stop while indoor fan will operate; During heating operation, the complete unit will stop operation	Replace outdoor control panel AP1 or Reactor

Analysis or processing of some of the malfunction display:

1. Compressor discharge protection

Possible causes: shortage of refrigerant; blockage of air filter; poor ventilation or air flow short pass for condenser; the system has noncondensing gas (such as air, water etc.); blockage of capillary assy (including filter); leakage inside four-way valve causes incorrect operation; malfunction of compressor; malfunction of protection relay; malfunction of discharge sensor; outdoor temperature too high.

Processing method: refer to the malfunction analysis in the above section.

2. Low voltage overcurrent protection

Possible cause: Sudden drop of supply voltage.

3.

Processing method: Check if communication signal cable is connected reliably.

4. Sensor open or short circuit

Processing method: Check whether sensor is normal, connected with the corresponding position on the controller and if damage of lead wire is found.

5. Compressor over load protection

Possible causes: insufficient or too much refrigerant; blockage of capillary and increase of suction temp.; improper running of compressor, burning in or stuck of bearing, damage of discharge valve; malfunction of protector.

Processing method: adjust refrigerant amount; replace the capillary; replace the compressor; use universal meter to check if the contactor of compressor is fine when it is not overheated, if not replace the protector.

6. System malfunction

i.e. overload protection. When tube temperature (Check the temperature of outdoor heat exchanger when cooling and check the temperature of indoor heat exchanger when heating) is too high, protection will be activated.

Possible causes: Outdoor temperature is too high when cooling; insufficient outdoor air circulation; refrigerant flow malfunction.

please refer to the malfunction analysis in the previous section for handling method .

7. IPM module protection

Processing method: Once the module malfunction happens, if it persists for a long time and can not be self-canceled, cut off the power and turn off the unit, and then re-energize the unit again after about 10 min. After repeating the procedure for several times, if the malfunction still exists, replace the module.

9.2 Procedure of Troubleshooting

Indoor unit

(1) Malfunction of Temperature Sensor F1, F2

Main detection points:

- Is the wiring terminal between the temperature sensor and the controller loosened or poorly contacted?
- Is there short circuit due to trip-over of the parts?
- Is the temperature sensor broken?
- Is mainboard broken?

Malfunction diagnosis process:

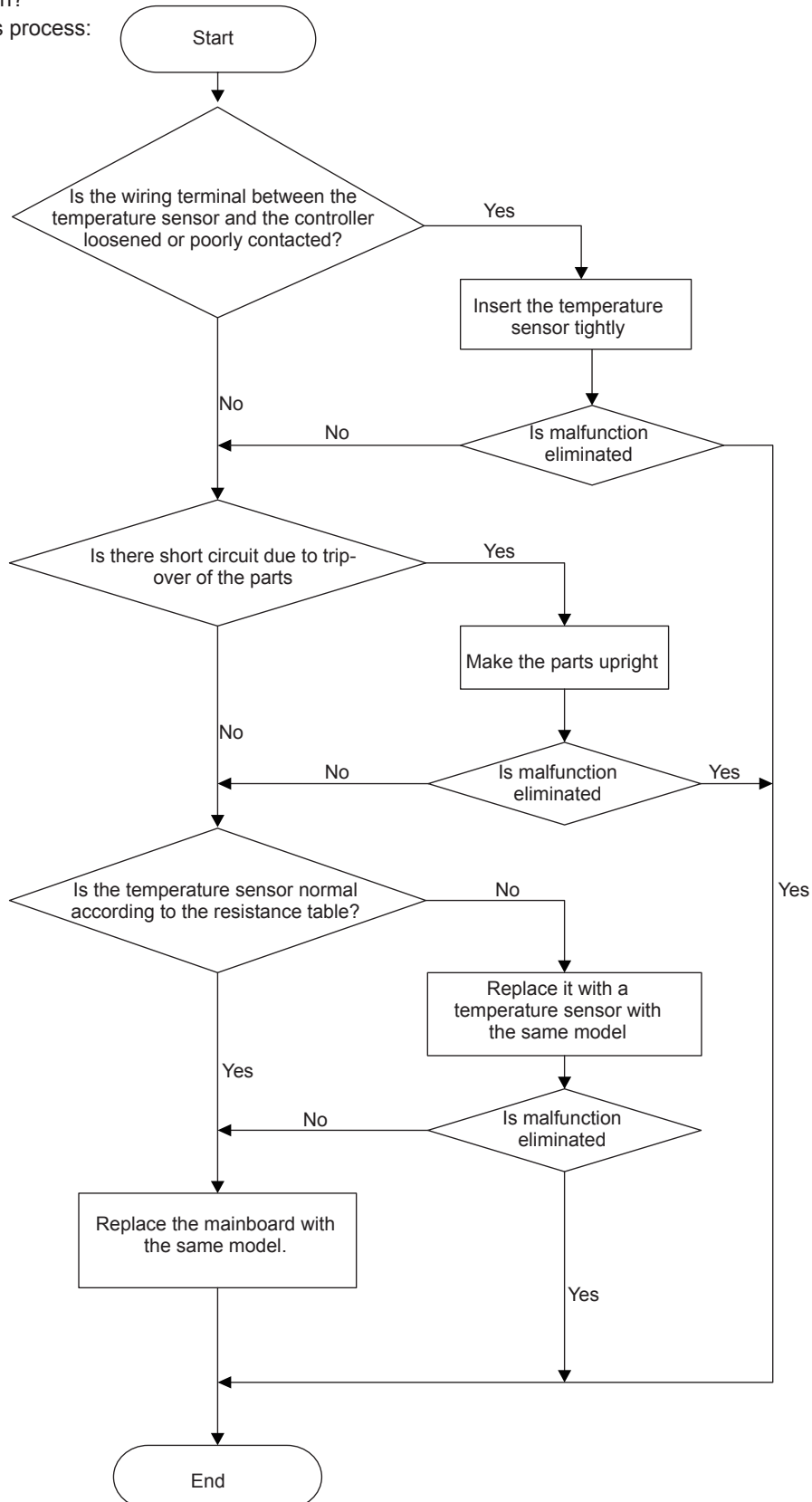

(2) Malfunction of Blocked Protection of IDU Fan Motor H6

Main detection points:

- Smoothly the control terminal of PG motor connected tightly?
- Smoothly the feedback interface of PG motor connected tightly?
- The fan motor cant operate?
- The motor is broken?
- Detection circuit of the mainboard is defined abnormal?

Malfunction diagnosis process:

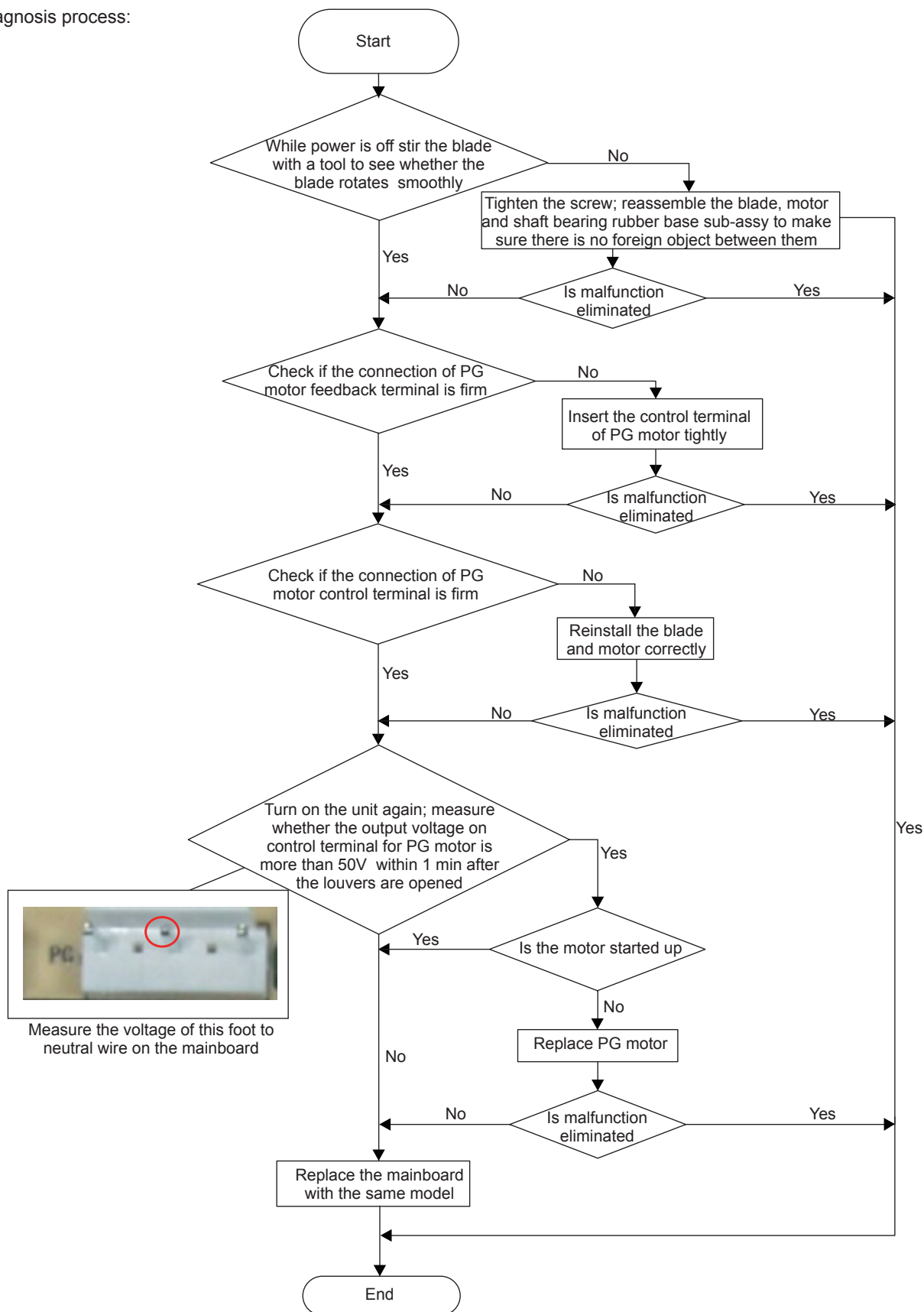

(4) Malfunction of Zero-crossing Inspection Circuit Malfunction of the IDU Fan Motor U8

Main detection points:

- Instant energization after de-energization while the capacitor discharges slowly?
- The zero-cross detection circuit of the mainboard is defined abnormal?

Malfunction diagnosis process:

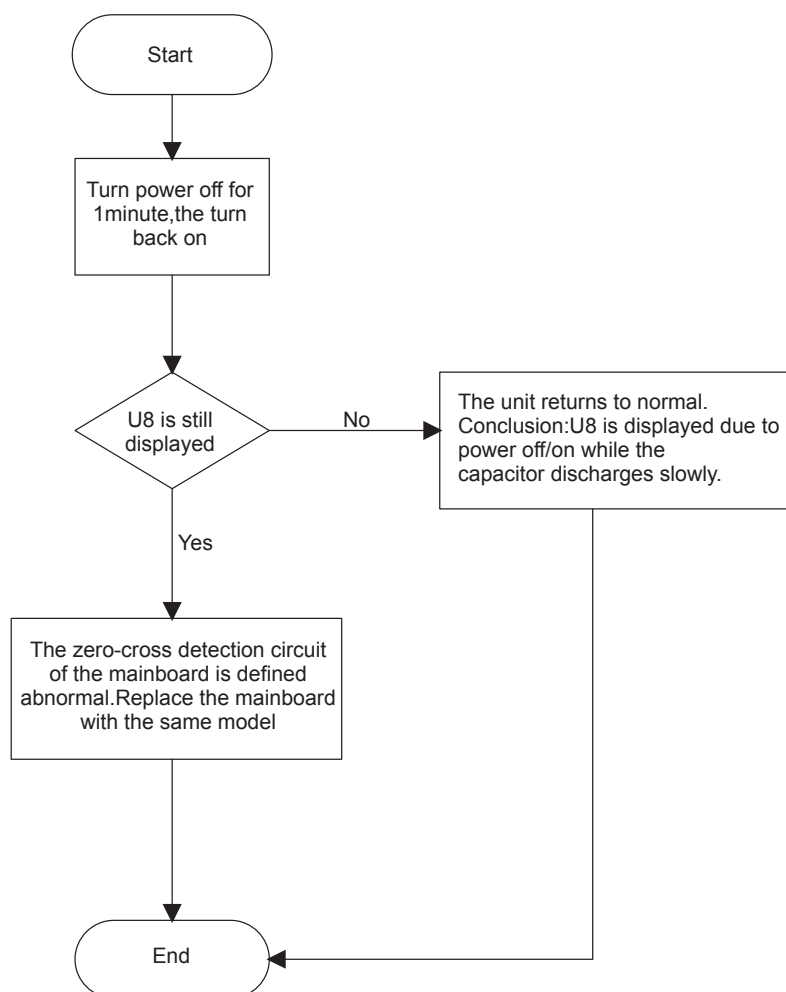

Outdoor unit:

(1) Capacitor charge fault (Fault with outdoor unit) (AP1 below refers to the outdoor control panel)

Main Check Points:

- Use AC voltmeter to check if the voltage between terminal L and N on the wiring board is within 210VAC~240VAC.
- Is the reactor (L) correctly connected? Is the connection loose or fallen? Is the reactor (L) damaged?

Fault diagnosis process:

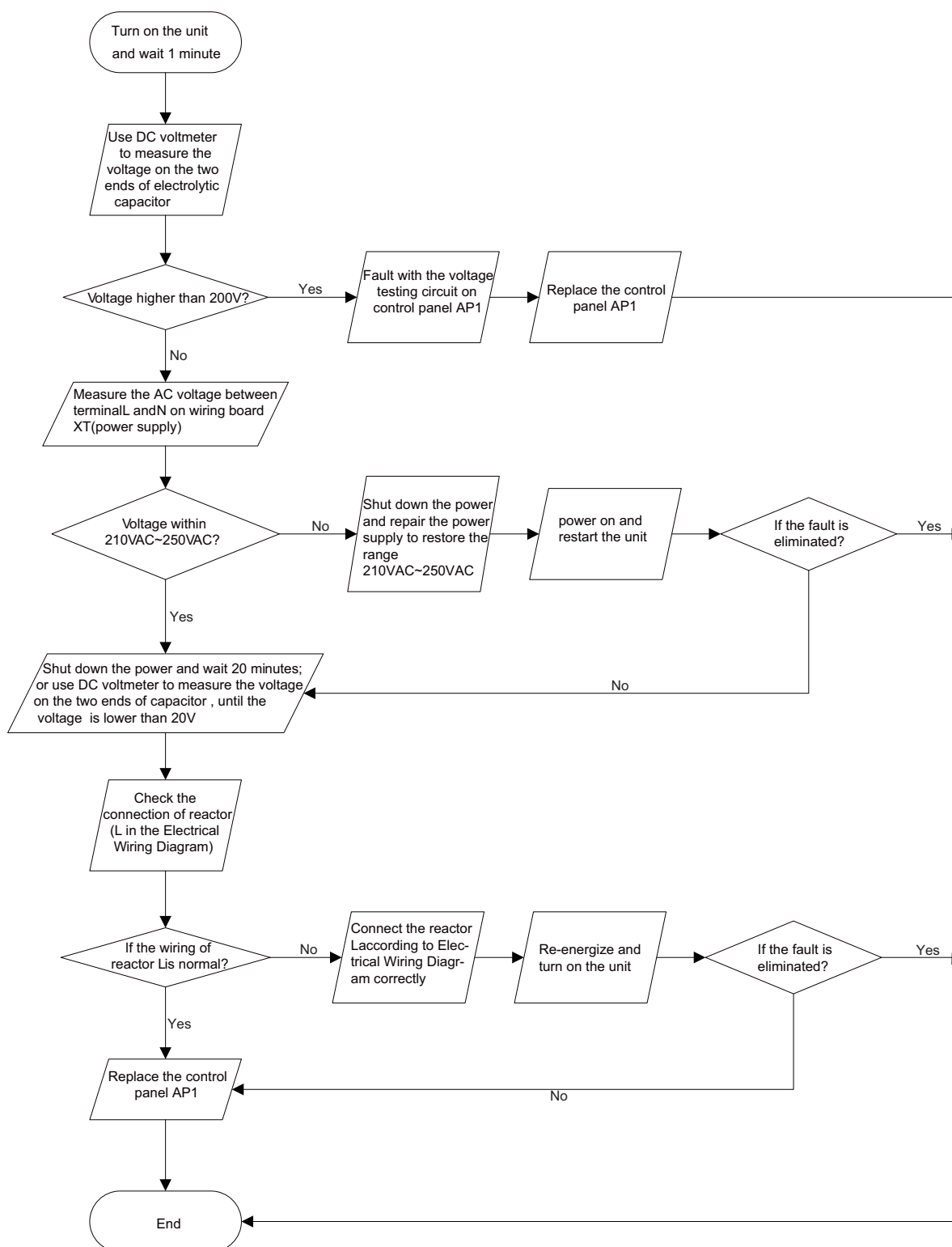

(2) IPM protection, phase current overcurrent (the control board as below indicates the control board of outdoor unit) H5/P5

Mainly detect:

- (1) Compressor COMP terminal (2) voltage of power supply (3) compressor
- (4) Refrigerant-charging volume (5) air outlet and air inlet of outdoor/indoor unit

Troubleshooting:

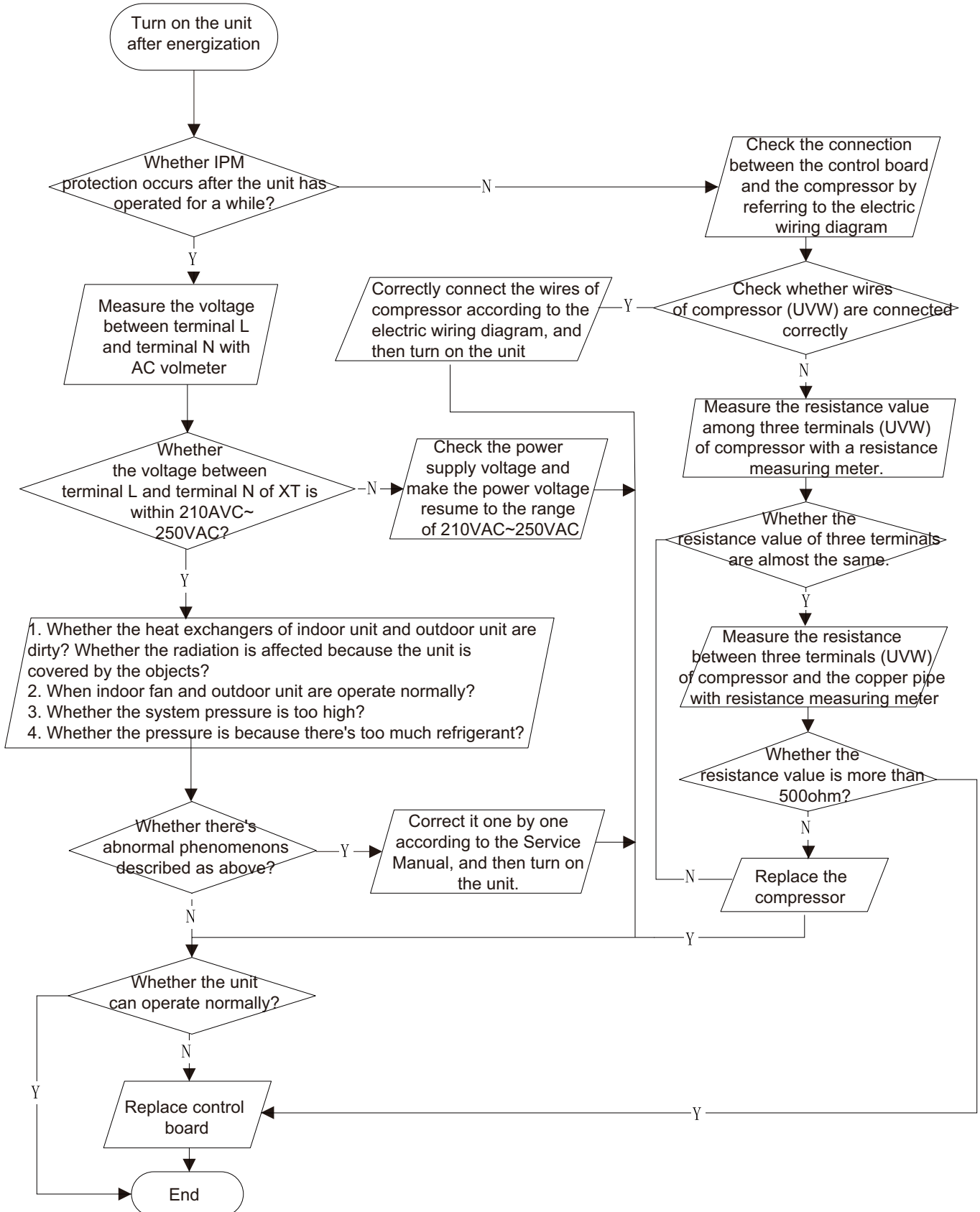

(3) High temperature and overload protection diagnosis (AP1 hereinafter refers to the control board of the outdoor unit)

Mainly detect:

- Is outdoor ambient temperature in normal range?
- Are the outdoor and indoor fans operating normally?
- Is the heat dissipation environment inside and outside the unit good?

Fault diagnosis process:

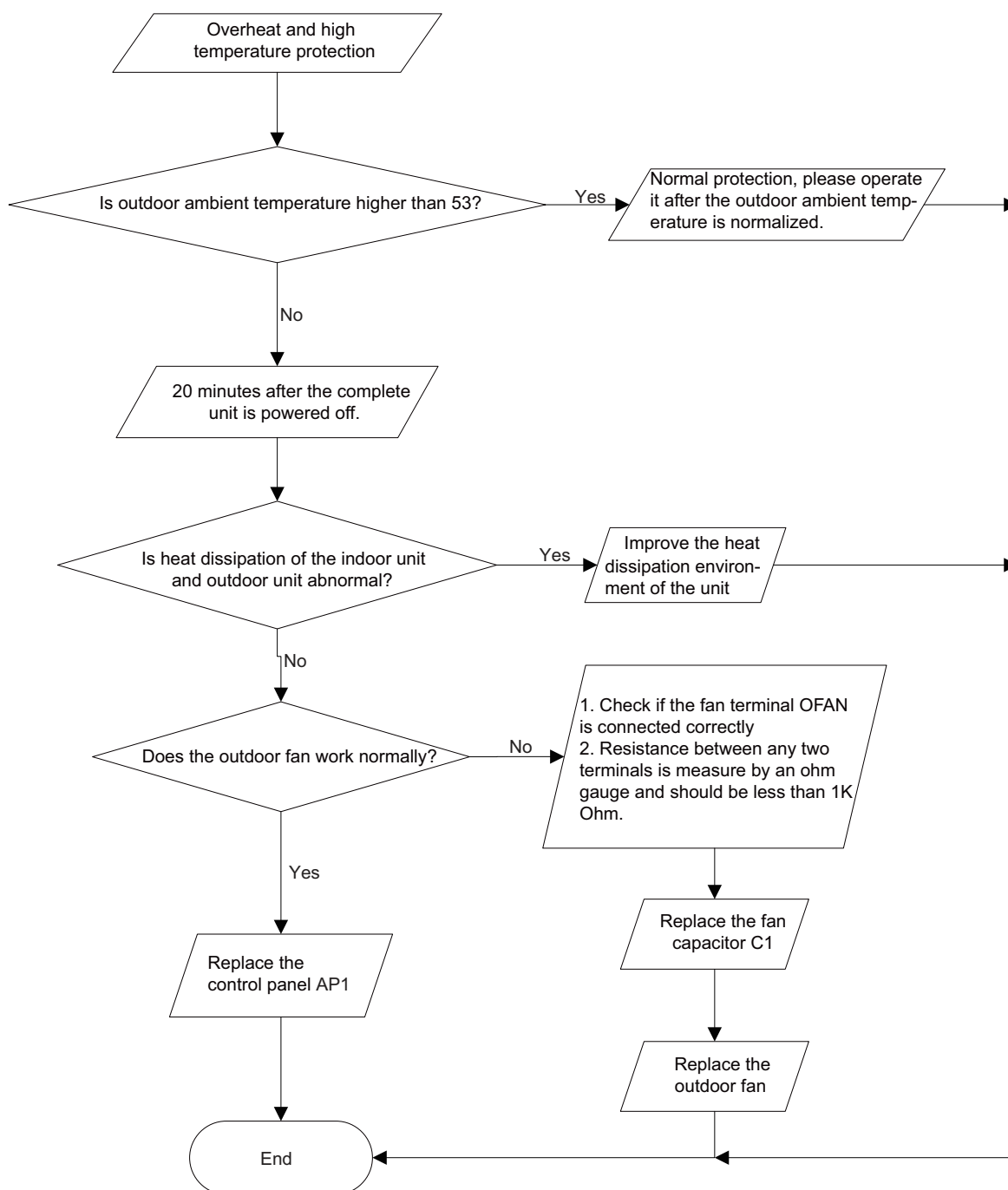

(4) Start-up failure (following AP1 for outdoor unit control board)

Mainly detect:

- Whether the compressor wiring is connected correct?
- Is compressor broken?
- Is time for compressor stopping enough?

Fault diagnosis process:

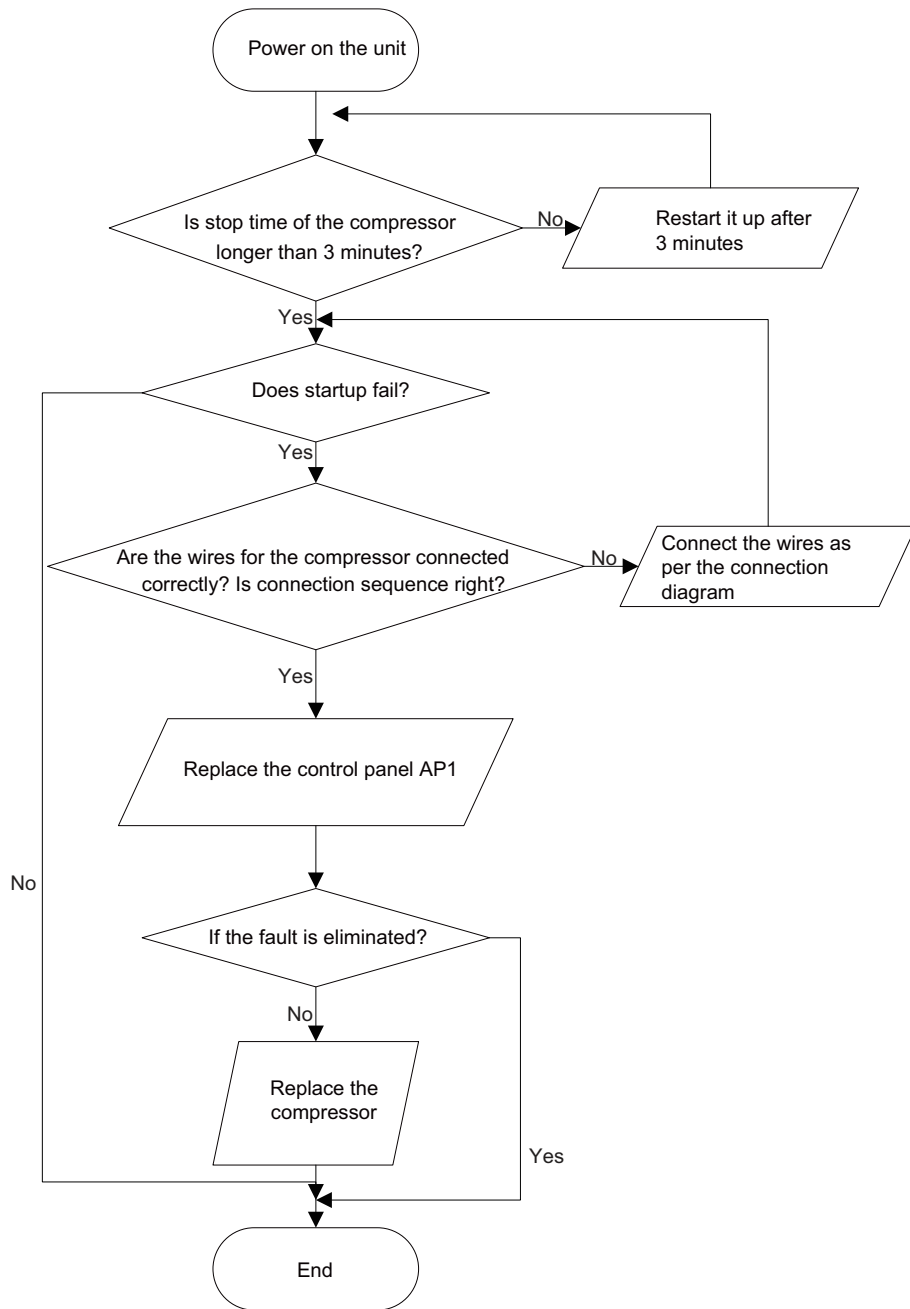

(5) Out of step diagnosis for the compressor (AP1 hereinafter refers to the control board of the outdoor unit)

Mainly detect:

- Is the system pressure too high?
- Is the input voltage too low?

Fault diagnosis process:

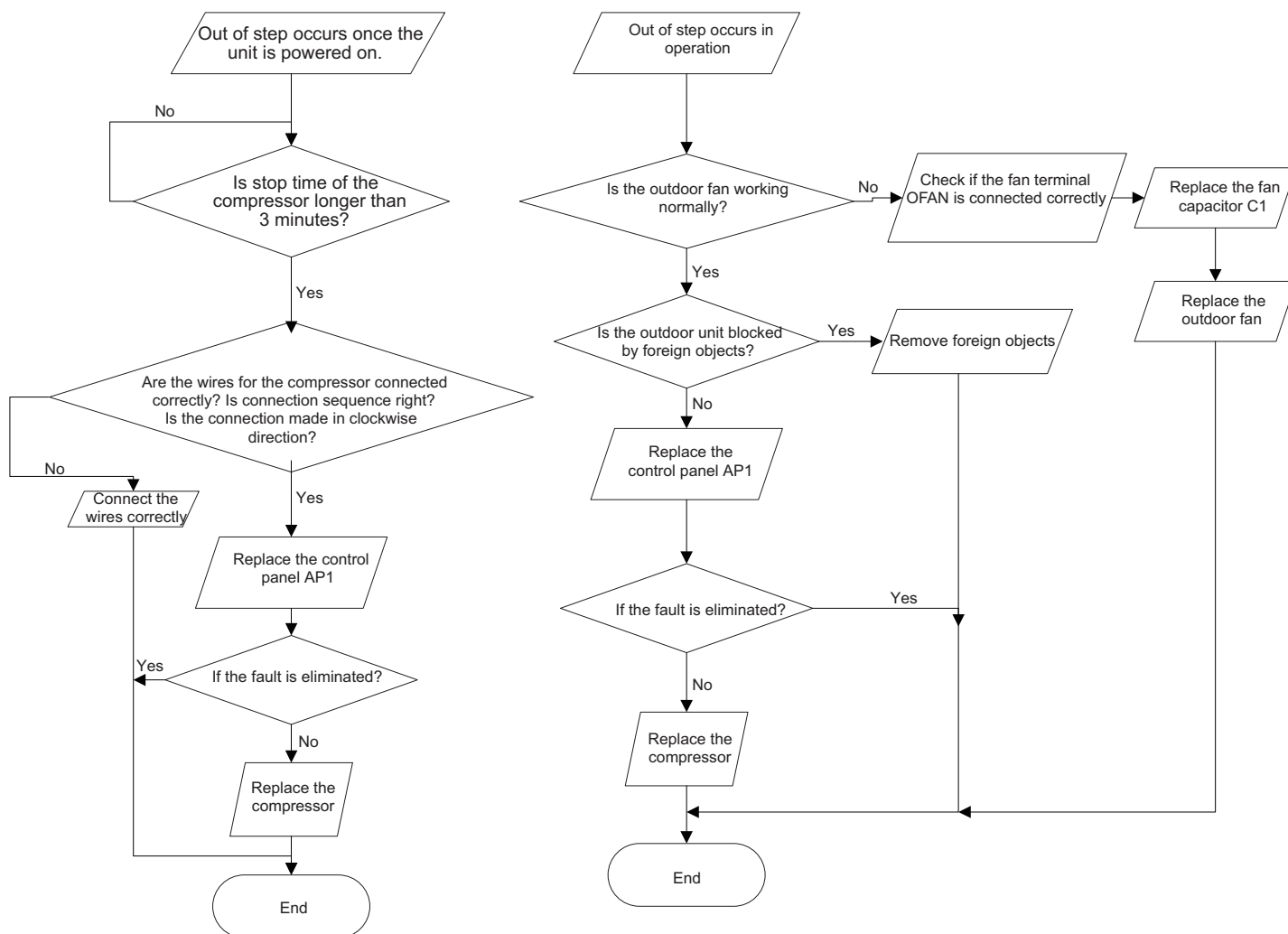

(6) Overload and air exhaust malfunction diagnosis (following AP1 for outdoor unit control board)

Mainly detect:

- Is the PMV connected well or not? Is PMV damaged?
- Is refrigerant leaked?

Fault diagnosis process:

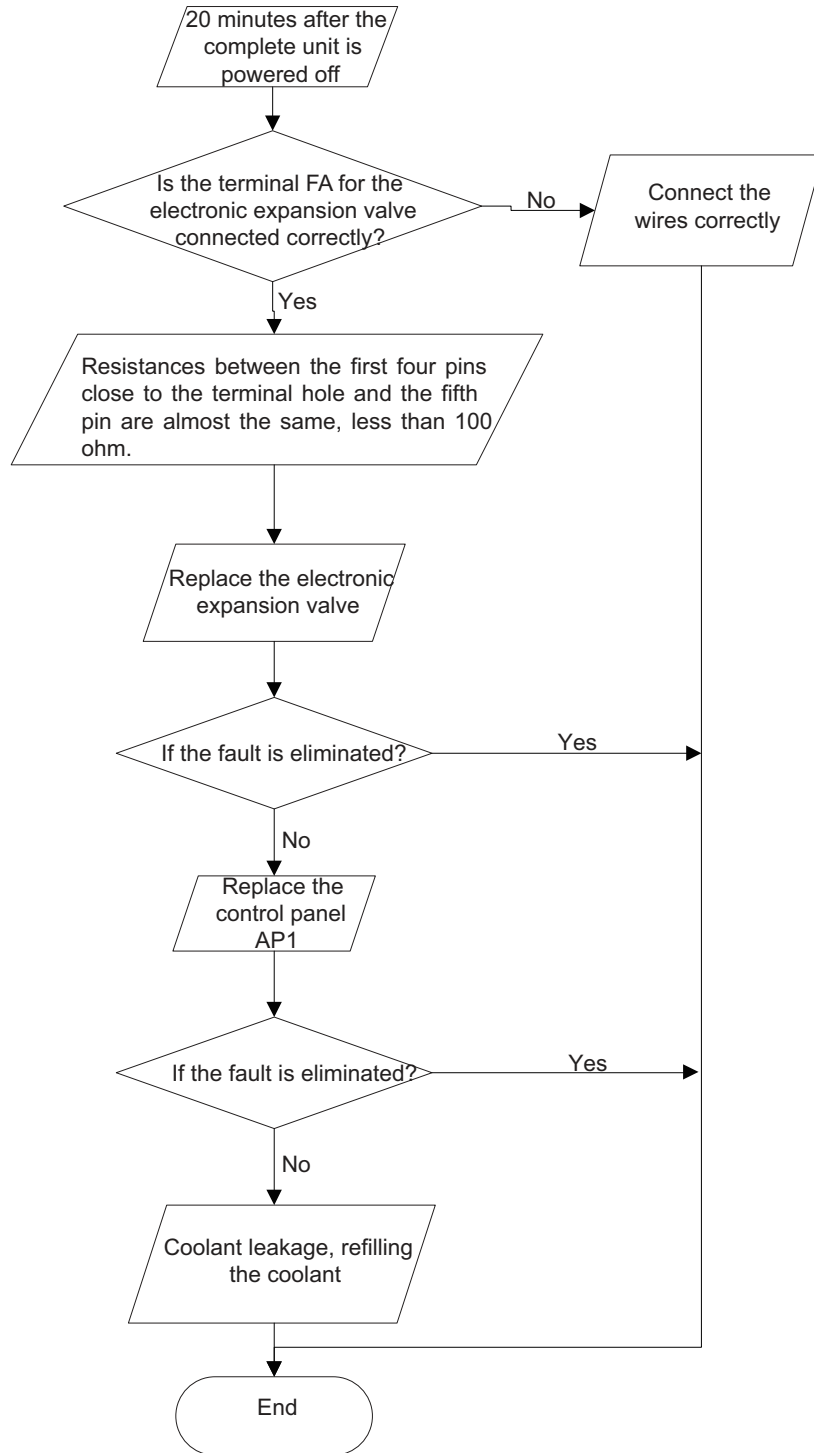

(7) Communication malfunction: (following AP1 for outdoor unit control board)

Mainly detect:

- Is there any damage for the indoor unit mainboard communication circuit? Is communication circuit damaged?
- Detect the indoor and outdoor units connection wire and indoor and outdoor units inside wiring is connect well or not, if is there any damage?

Fault diagnosis process:

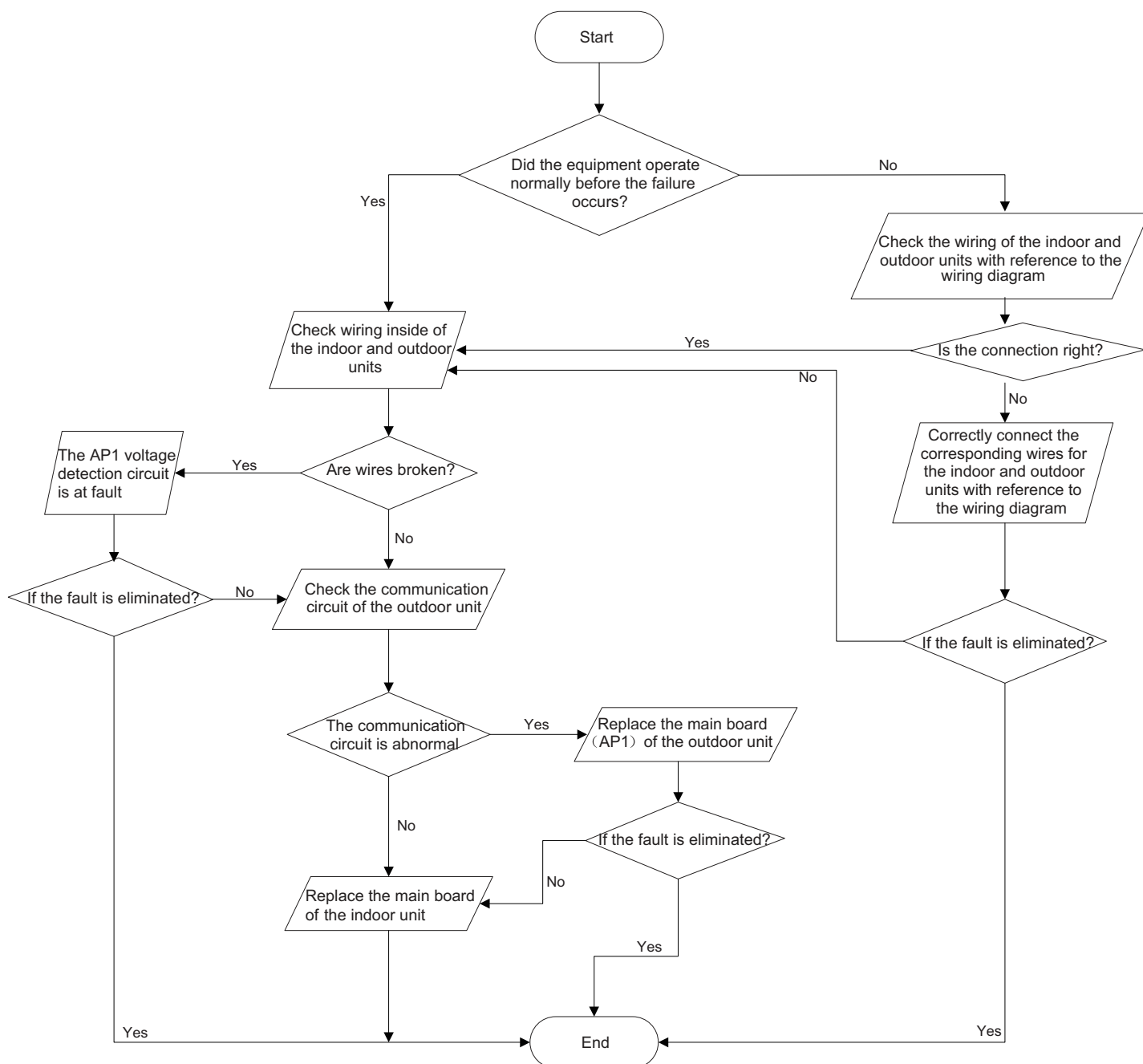

(8) Malfunction of Overcurrent Protection

Main detection points:

- Is the supply voltage unstable with big fluctuation?
- Is the supply voltage too low with overload?
- Hardware trouble?

Malfunction diagnosis process:

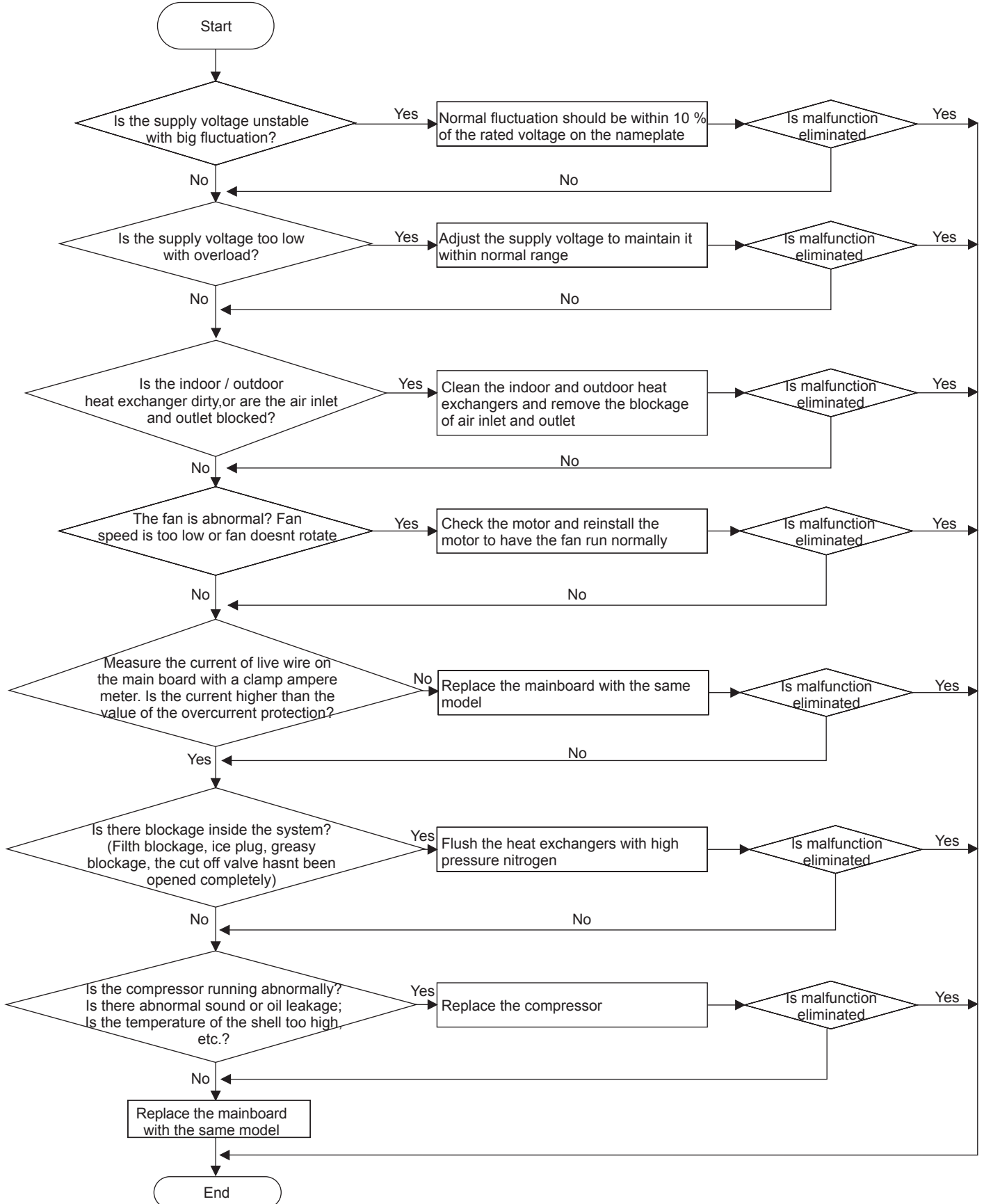

9.3 Troubleshooting for Normal Malfunction

1. Air Conditioner Cant be Started Up

Possible Causes	Discriminating Method (Air conditioner Status)	Troubleshooting
No power supply, or poor connection for power plug	After energization, operation indicator isnt bright and the buzzer cant give out sound	Confirm whether its due to power failure. If yes, wait for power recovery. If not, check power supply circuit and make sure the power plug is connected well.
Wrong wire connection between indoor unit and outdoor unit, or poor connection for wiring terminals	Under normal power supply circumstances, operation indicator isnt bright after energization	Check the circuit according to circuit diagram and connect wires correctly. Make sure all wiring terminals are connected firmly
Electric leakage for air conditioner	After energization, room circuit breaker trips off at once	Make sure the air conditioner is grounded reliably Make sure wires of air conditioner is connected correctly Check the wiring inside air conditioner. Check whether the insulation layer of power cord is damaged; if yes, place the power cord.
Model selection for air switch is improper	After energization, air switch trips off	Select proper air switch
Malfunction of remote controller	After energization, operation indicator is bright, while no display on remote controller or buttons have no action.	Replace batteries for remote controller Repair or replace remote controller

2. Poor Cooling (Heating) for Air Conditioner

Possible Causes	Discriminating Method (Air conditioner Status)	Troubleshooting
Set temperature is improper	Observe the set temperature on remote controller	Adjust the set temperature
Rotation speed of the IDU fan motor is set too low	Small wind blow	Set the fan speed at high or medium
Filter of indoor unit is blocked	Check the filter to see its blocked	Clean the filter
Installation position for indoor unit and outdoor unit is improper	Check whether the installation position is proper according to installation requirement for air conditioner	Adjust the installation position, and install the rainproof and sunproof for outdoor unit
Refrigerant is leaking	Discharged air temperature during cooling is higher than normal discharged wind temperature; Discharged air temperature during heating is lower than normal discharged wind temperature; Units pressure is much lower than regulated range	Find out the leakage causes and deal with it. Add refrigerant.
Malfunction of 4-way valve	Blow cold wind during heating	Replace the 4-way valve
Malfunction of capillary	Discharged air temperature during cooling is higher than normal discharged wind temperature; Discharged air temperature during heating is lower than normal discharged wind temperature; Unit pressure is much lower than regulated range. If refrigerant isnt leaking, part of capillary is blocked	Replace the capillary
Flow volume of valve is insufficient	The pressure of valves is much lower than that stated in the specification	Open the valve completely
Malfunction of horizontal louver	Horizontal louver cant swing	Refer to point 3 of maintenance method for details
Malfunction of the IDU fan motor	The IDU fan motor cant operate	Refer to troubleshooting for H6 for maintenance method in details
Malfunction of the ODU fan motor	The ODU fan motor cant operate	Refer to point 4 of maintenance method for details
Malfunction of compressor	Compressor cant operate	Refer to point 5 of maintenance method for details

3. Horizontal Louver Cant Swing

Possible Causes	Discriminating Method (Air conditioner Status)	Troubleshooting
Wrong wire connection, or poor connection	Check the wiring status according to circuit diagram	Connect wires according to wiring diagram to make sure all wiring terminals are connected firmly
Stepping motor is damaged	Stepping motor cant operate	Repair or replace stepping motor
Main board is damaged	Others are all normal, while horizontal louver cant operate	Replace the main board with the same model

4. ODU Fan Motor Cant Operate

Possible causes	Discriminating method (air conditioner status)	Troubleshooting
Wrong wire connection, or poor connection	Check the wiring status according to circuit diagram	Connect wires according to wiring diagram to make sure all wiring terminals are connected firmly
Capacity of the ODU fan motor is damaged	Measure the capacity of fan capacitor with an universal meter and find that the capacity is out of the deviation range indicated on the nameplate of fan capacitor.	Replace the capacity of fan
Power voltage is a little low or high	Use universal meter to measure the power supply voltage. The voltage is a little high or low	Suggest to equip with voltage regulator
Motor of outdoor unit is damaged	When unit is on, cooling/heating performance is bad and ODU compressor generates a lot of noise and heat.	Change compressor oil and refrigerant. If no better, replace the compressor with a new one

5. Compressor Cant Operate

Possible causes	Discriminating method (air conditioner status)	Troubleshooting
Wrong wire connection, or poor connection	Check the wiring status according to circuit diagram	Connect wires according to wiring diagram to make sure all wiring terminals are connected firmly
Capacity of compressor is damaged	Measure the capacity of fan capacitor with an universal meter and find that the capacity is out of the deviation range indicated on the nameplate of fan capacitor.	Replace the compressor capacitor
Power voltage is a little low or high	Use universal meter to measure the power supply voltage. The voltage is a little high or low	Suggest to equip with voltage regulator
Coil of compressor is burnt out	Use universal meter to measure the resistance between compressor terminals and its 0	Repair or replace compressor
Cylinder of compressor is blocked	Compressor cant operate	Repair or replace compressor

6. Air Conditioner is Leaking

Possible causes	Discriminating method (air conditioner status)	Troubleshooting
Drain pipe is blocked	Water leaking from indoor unit	Eliminate the foreign objects inside the drain pipe
Drain pipe is broken	Water leaking from drain pipe	Replace drain pipe
Wrapping is not tight	Water leaking from the pipe connection place of indoor unit	Wrap it again and bundle it tightly

7. Abnormal Sound and Vibration

Possible causes	Discriminating method (air conditioner status)	Troubleshooting
When turn on or turn off the unit, the panel and other parts will expand and theres abnormal sound	Theres the sound of "PAPA"	Normal phenomenon. Abnormal sound will disappear after a few minutes.
When turn on or turn off the unit, theres abnormal sound due to flow of refrigerant inside air conditioner	Water-running sound can be heard	Normal phenomenon. Abnormal sound will disappear after a few minutes.
Foreign objects inside the indoor unit or therere parts touching together inside the indoor unit	Theres abnormal sound fro indoor unit	Remove foreign objects. Adjust all parts position of indoor unit, tighten screws and stick damping plaster between connected parts
Foreign objects inside the outdoor unit or therere parts touching together inside the outdoor unit	Theres abnormal sound fro outdoor unit	Remove foreign objects. Adjust all parts position of outdoor unit, tighten screws and stick damping plaster between connected parts
Short circuit inside the magnetic coil	During heating, the way valve has abnormal electromagnetic sound	Replace magnetic coil
Abnormal shake of compressor	Outdoor unit gives out abnormal sound	Adjust the support foot mat of compressor, tighten the bolts
Abnormal sound inside the compressor	Abnormal sound inside the compressor	If add too much refrigerant during maintenance, please reduce refrigerant properly. Replace compressor for other circumstances.

10. Exploded View and Parts List

10.1 Indoor Unit

09/12K For some models

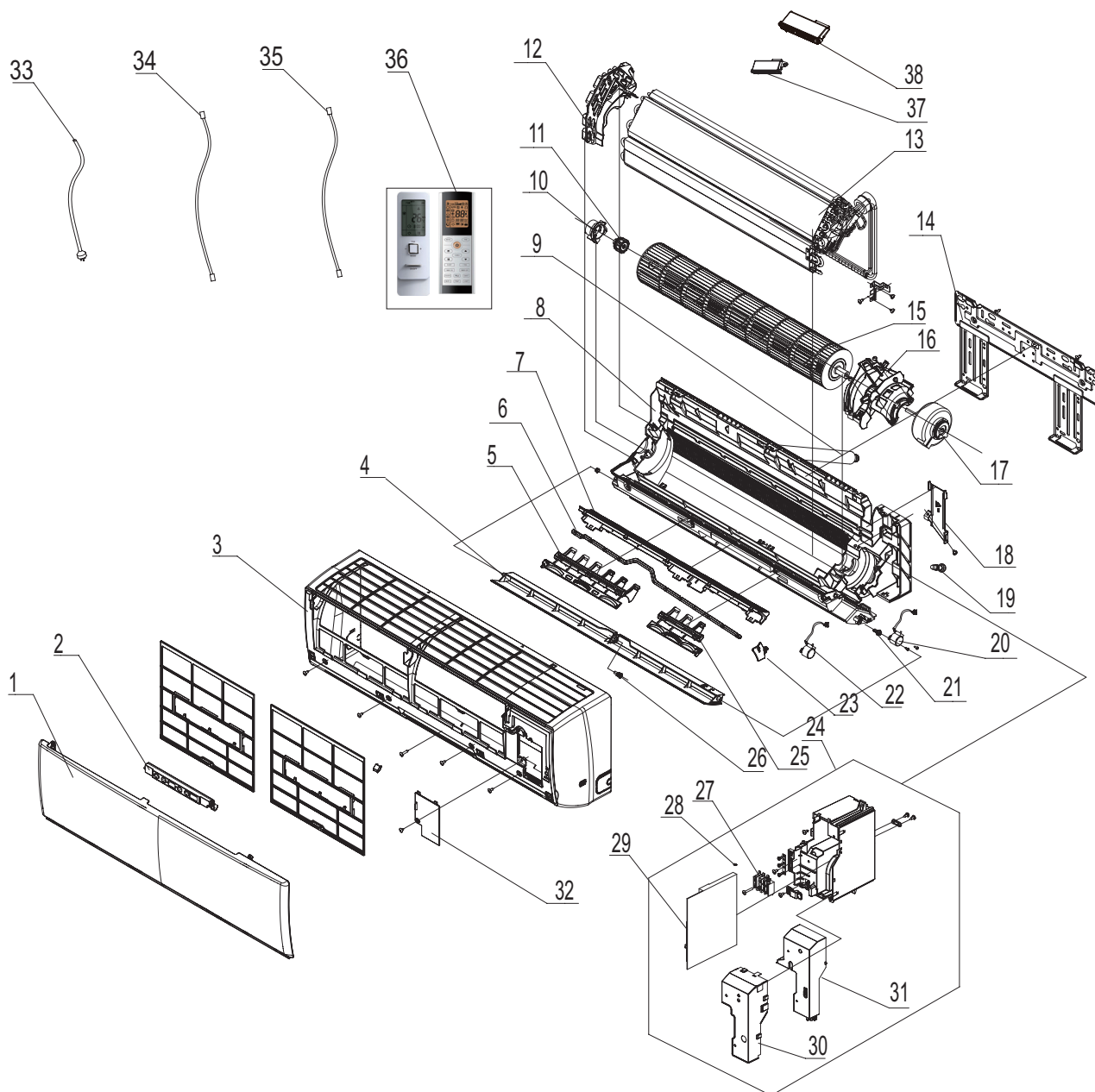

The component picture is only for reference; please refer to the actual product.

NO.	Description	Part Code			Qty
		GWH12QC-K6DNA1D/I	GWH09QB-K6DNB6E/I	GWH09QB-K6DNC2E/I	
	Product Code	CB419N15500	CB435N09600	CB439N13300	
1	Front Panel	20022475	20000300050T	20000300068S	1
2	Display Board	30565231	30565281	30565281	1
3	Front Case Assy	20022489	00000200040	00000200040	1
4	Guide Louver	10512492	1051276301	1051276301	1
5	Air Louver (left)	10512725	10512720	10512720	1
6	Swing Lever	10582459	10582460	10582460	1
7	Helicoid Tongue	26112436	26112508	26112508	1
8	Rear Case assy	00000100092	20022682	20022682	1
9	Drainage Hose	05230014	0523001408	0523001408	1
10	Ring of Bearing	26152022	26152022	26152022	1
11	O-Gasket sub-assy of Bearing	7651205102	7651205102	7651205102	1
12	Evaporator Support 2	24212179	24212180	24212180	1
13	Evaporator Assy	011001060162	0110010009505	0110010009505	1
14	Wall Mounting Frame	01252484	01252043	01252043	1
15	Cross Flow Fan	10352056	10352059	10352059	1
16	Motor Press Plate	26112516	26112373	26112373	1
17	Fan Motor	1501214606	150120874	150120874	1
18	Connecting pipe clamp	2611216401	2611216401	2611216401	1
19	Rubber Plug (Water Tray)	76712012	76712012	76712012	1
20	Stepping Motor	1521210710	1521210704	1521210704	1
21	Crank	73012005	73012005	73012005	1
22	Stepping Motor	1521210108	1521212901	1521212901	1
23	Air Louver(right)	10512726	10512740	10512740	1
24	Electric Box Assy	100002061123	100002062338	100002062338	1
25	Air Louver 1	10512727	10512739	10512739	1
26	Axile Bush	10542036	10542036	10542036	1
27	Terminal Board	42011233	42011233	42011233	1
28	Jumper	4202021906	4202021908	4202021908	1
29	Main Board	300002060230	300002060228	300002060228	1
30	Shield Cover of Electric Box Cover	01592150	01592150	01592150	1
31	Electric Box Cover Sub-Assy	0140206501	0140206501	0140206501	1
32	Electric Box Cover	2011220701	20112207	20112207	1
33	Power Cord	/	/	/	/
34	Connecting Cable	4002052317	4002052317	4002052317	0
35	Connecting Cable	/	/	/	/
36	Remote Control	305001060023	305001060023	305001060023	1
37	Cold Plasma Generator	1114001603	1114001603	1114001603	1
38	Detecting Plate	30110144	30110154	30110154	1

Above data is subject to change without notice.

NO.	Description	Part Code			Qty
		GWH09QB-K6DNA1E/I	GWH09QB-K6DNA5E/I	GWH09QB-K6DNC4E/I	
		Product Code	CB419N15800	CB425N12500	
1	Front Panel Assy	20022496	00000300036	20000300105	1
2	Display Board	30565231	30565260	30565260	1
3	Front Case Assy	20022495	2002249501	00000200040	1
4	Guide Louver	10512722	1051272202	1051276301	1
5	Air Louver 2	10512720	10512720	10512720	1
6	Swing Lever	10582460	10582460	10582460	1
7	Helicoid Tongue	26112508	26112508	26112508	1
8	Rear Case	2220255501	2220255501	2220255501	1
9	Drainage Hose	0523001408	0523001408	0523001408	1
10	Ring of Bearing	26152022	26152022	26152022	1
11	O-Gasket sub-assy of Bearing	7651205102	7651205102	7651205102	1
12	Evaporator Support	24212180	24212180	24212180	1
13	Evaporator Assy	0110010009505	0110010009505	0110010009508	1
14	Wall Mounting Frame	01252043	01252043	01252043	1
15	Cross Flow Fan	10352059	10352059	10352059	1
16	Motor Press Plate	26112373	26112373	26112373	1
17	Fan Motor	150120874	150120874	150120874	1
18	Connecting pipe clamp	2611216401	2611216401	2611216401	1
19	Rubber Plug (Water Tray)	76712012	76712012	76712012	1
20	Stepping Motor	1521212901	1521212901	1521212901	1
21	Crank	73012005	73012005	73012005	1
22	Stepping Motor	1521210704	1521210704	1521210704	1
23	Air Louver 3	10512739	10512739	10512739	1
24	Electric Box Assy	100002061367	100002062334	100002062070	1
25	Air Louver 1	10512740	10512740	10512740	1
26	Axile Bush	10542036	10542036	10542036	1
27	Terminal Board	42011233	42011233	42011233	1
28	Jumper	4202021902	4202021902	4202021908	1
29	Main Board	300002060228	300002060228	300002060229	1
30	Shield Cover of Electric Box Cover	01592150	01592150	01592150	1
31	Electric Box Cover Sub-Assy	0140206501	0140206501	0140206501	1
32	Electric Box Cover	20112207	20112207	20112207	1
33	Power Cord	/	/	/	/
34	Connecting Cable	4002052317	4002052317	4002052317	0
35	Connecting Cable	/	/	/	/
36	Remote Controller	305001060023	305001060023	305001060023	1
37	Cold Plasma Generator	1114001603	1114001603	/	1
38	Detecting Plate	30110154	30110154	30110154	1

Above data is subject to change without notice.

NO.	Description	Part Code			Qty
		GWH09QB-K6DNB2E/I	GWH09QB-K6DNE4E/I	GWH09QB-K6DNB4E/I	
		Product Code	CB432N17600	CB470N02700	
1	Front Panel Assy	20000300019	200003000065	20000300026	1
2	Display Board	30565260	300001000081	30565260	1
3	Front Case Assy	00000200040	00000200040	00000200040	1
4	Guide Louver	1051276301	1051276301	1051276301	1
5	Air Louver 2	10512720	10512720	10512720	1
6	Swing Lever	10582460	10582460	10582460	1
7	Helicoid Tongue	26112508	26112508	26112508	1
8	Rear Case	2220255501	2220255501	2220255501	1
9	Drainage Hose	0523001408	0523001408	0523001408	1
10	Ring of Bearing	26152022	26152022	26152022	1
11	O-Gasket sub-assy of Bearing	7651205102	7651205102	7651205102	1
12	Evaporator Support	24212180	24212180	24212180	1
13	Evaporator Assy	0110010009505	0110010009505	0110010009505	1
14	Wall Mounting Frame	01252043	01252043	01252043	1
15	Cross Flow Fan	10352059	10352059	10352059	1
16	Motor Press Plate	26112373	26112373	26112373	1
17	Fan Motor	150120874	150120874	150120874	1
18	Connecting pipe clamp	2611216401	2611216401	2611216401	1
19	Rubber Plug (Water Tray)	76712012	76712012	76712012	1
20	Stepping Motor	1521212901	1521212901	1521212901	1
21	Crank	73012005	73012005	73012005	1
22	Stepping Motor	1521210704	1521210704	1521210704	1
23	Air Louver 3	10512739	10512739	10512739	1
24	Electric Box Assy	100002062339	100002062337	100002062339	1
25	Air Louver 1	10512740	10512740	10512740	1
26	Axile Bush	10542036	10542036	10542036	1
27	Terminal Board	42011233	42011233	42011233	1
28	Jumper	4202021908	4202021908	4202021908	1
29	Main Board	300002060228	300002060228	300002060228	1
30	Shield Cover of Electric Box Cover	01592150	01592150	01592150	1
31	Electric Box Cover Sub-Assy	0140206501	0140206501	0140206501	1
32	Electric Box Cover	20112207	20112207	20112207	1
33	Power Cord	/	/	/	/
34	Connecting Cable	4002052317	4002052317	4002052317	0
35	Connecting Cable	/	/	/	/
36	Remote Controller	305001060023	305001060023	305001060023	1
37	Cold Plasma Generator	1114001603	1114001603	1114001603	1
38	Detecting Plate	30110154	30110154	30110154	1

Above data is subject to change without notice.

NO.	Description	Part Code			Qty
		GWH12QC-K6DNA5D/I	GWH12QC-K6DNE4D/I	GWH12QC-K6DNB6D/I	
	Product Code	CB425N12300	CB470N02900	CB435N09400	
1	Front Panel Assy	00000300022	200003000067T	20000300049T	1
2	Display Board	30565260	300001000081	30565281	1
3	Front Case Assy	00000200022	00000200045	00000200045	1
4	Guide Louver	1051249202	1051293101	1051293101	1
5	Air Louver 2	10512725	10512725	10512725	1
6	Swing Lever	10582459	10582459	10582459	1
7	Helicoid Tongue	26112436	26112436	26112436	1
8	Rear Case	00000100092	00000100092	00000100092	1
9	Drainage Hose	05230014	05230014	05230014	1
10	Ring of Bearing	26152022	26152022	26152022	1
11	O-Gasket sub-assy of Bearing	7651205102	7651205102	7651205102	1
12	Evaporator Support	24212179	24212179	24212179	1
13	Evaporator Assy	011001060162	011001060162	011001060162	1
14	Wall Mounting Frame	01252484	01252484	01252484	1
15	Cross Flow Fan	10352056	10352056	10352056	1
16	Motor Press Plate	26112516	26112516	26112516	1
17	Fan Motor	1501214606	1501214606	1501214606	1
18	Connecting pipe clamp	2611216401	2611216401	2611216401	1
19	Rubber Plug (Water Tray)	76712012	76712012	76712012	1
20	Stepping Motor	1521210108	1521210108	1521210108	1
21	Crank	73012005	73012005	73012005	1
22	Stepping Motor	1521210710	1521210710	1521210710	1
23	Air Louver 3	10512726	10512726	10512726	1
24	Electric Box Assy	10000204671	100002062377	10000204858	1
25	Air Louver 1	10512727	10512727	10512727	1
26	Axile Bush	10542036	10542036	10542036	1
27	Terminal Board	42011233	42011233	42011233	1
28	Jumper	4202021906	4202021917	4202021917	1
29	Main Board	300002060230	300002060230	300002060230	1
30	Shield Cover of Electric Box Cover	01592150	01592150	01592150	1
31	Electric Box Cover Sub-Assy	0140206501	0140206501	0140206501	1
32	Electric Box Cover	2011220701	2011220701	2011220701	1
33	Power Cord	/	/	/	/
34	Connecting Cable	4002052317	4002052317	4002052317	0
35	Connecting Cable	/	/	/	/
36	Remote Controller	305001060023	305001060023	305001060023	1
37	Cold Plasma Generator	1114001603	1114001603	1114001603	1
38	Detecting Plate	30110144	30110144	30110144	1

Above data is subject to change without notice.

NO.	Description	Part Code			Qty
		GWH12QC-K6DNC2D/I	GWH12QC-K6DNB4D/I	GWH12QC-K6DNB2D/I	
	Product Code	CB439N13100	CB434N12600	CB432N17800	
1	Front Panel Assy	20000300069S	20000300027T	20000300018S	1
2	Display Board	30565281	30565260	30565260	1
3	Front Case Assy	00000200045	00000200045	00000200045	1
4	Guide Louver	1051293101	1051293101	1051293101	1
5	Air Louver 2	10512725	10512725	10512725	1
6	Swing Lever	10582459	10582459	10582459	1
7	Helicoid Tongue	26112436	26112436	26112436	1
8	Rear Case	00000100092	00000100092	00000100092	1
9	Drainage Hose	05230014	05230014	05230014	1
10	Ring of Bearing	26152022	26152022	26152022	1
11	O-Gasket sub-assy of Bearing	7651205102	7651205102	7651205102	1
12	Evaporator Support	24212179	24212179	24212179	1
13	Evaporator Assy	011001060162	011001060162	011001060162	1
14	Wall Mounting Frame	01252484	01252484	01252484	1
15	Cross Flow Fan	10352056	10352056	10352056	1
16	Motor Press Plate	26112516	26112516	26112516	1
17	Fan Motor	1501214606	1501214606	1501214606	1
18	Connecting pipe clamp	2611216401	2611216401	2611216401	1
19	Rubber Plug (Water Tray)	76712012	76712012	76712012	1
20	Stepping Motor	1521210108	1521210108	1521210108	1
21	Crank	73012005	73012005	73012005	1
22	Stepping Motor	1521210710	1521210710	1521210710	1
23	Air Louver 3	10512726	10512726	10512726	1
24	Electric Box Assy	10000204858	100002060206	100002060206	1
25	Air Louver 1	10512727	10512727	10512727	1
26	Axile Bush	10542036	10542036	10542036	1
27	Terminal Board	42011233	42011233	42011233	1
28	Jumper	4202021917	4202021906	4202021917	1
29	Main Board	300002060230	300002060230	300002060230	1
30	Shield Cover of Electric Box Cover	01592150	01592150	01592150	1
31	Electric Box Cover Sub-Assy	0140206501	0140206501	0140206501	1
32	Electric Box Cover	2011220701	2011220701	2011220701	1
33	Power Cord	/	/	/	/
34	Connecting Cable	4002052317	4002052317	4002052317	0
35	Connecting Cable	/	/	/	/
36	Remote Controller	305001060023	305001060023	305001060023	1
37	Cold Plasma Generator	1114001603	1114001603	1114001603	1
38	Detecting Plate	30110144	30110144	30110144	1

Above data is subject to change without notice.

NO.	Description	Part Code			Qty
		GWH09QB-K6DNB6E/I	GWH09QB-K6DNB8E/I	GWH12QC-K6DNB8D/I	
	Product Code	CB435N09600	CB438N10100	CB438N10200	
1	Front Panel Assy	20000300050T	20000300073T	20000300074T	1
2	Display Board	30565281	30565260	30565260	1
3	Front Case Assy	00000200040	00000200040	00000200045	1
4	Guide Louver	1051276301	1051276301	1051293101	1
5	Air Louver 2	10512720	10512720	10512720	1
6	Swing Lever	10582460	10582460	10582459	1
7	Helicoid Tongue	26112508	26112508	26112436	1
8	Rear Case	2220255501	2220255501	2220255501	1
9	Drainage Hose	0523001408	0523001408	05230014	1
10	Ring of Bearing	26152022	26152022	26152022	1
11	O-Gasket sub-assy of Bearing	76512051	76512051	76512051	1
12	Evaporator Support	24212180	24212180	24212180	1
13	Evaporator Assy	0110010009505	0110010009505	011001060162	1
14	Wall Mounting Frame	01252043	01252043	01252484	1
15	Cross Flow Fan	10352059	10352059	10352056	1
16	Motor Press Plate	26112373	26112373	26112516	1
17	Fan Motor	150120874	150120874	1501214606	1
18	Connecting pipe clamp	2611216401	2611216401	2611216401	1
19	Rubber Plug (Water Tray)	76712012	76712012	76712012	1
20	Stepping Motor	1521212901	1521212901	1521210710	1
21	Crank	73012005	73012005	73012005	1
22	Stepping Motor	1521210704	1521210704	1521210108	1
23	Air Louver 3	10512739	10512739	10512739	1
24	Electric Box Assy	100002062338	100002062339	100002060206	1
25	Air Louver 1	10512740	10512740	10512740	1
26	Axile Bush	10542036	10542036	10542036	1
27	Terminal Board	42011233	42011233	42011233	1
28	Jumper	4202021908	4202021908	4202021917	1
29	Main Board	300002060228	300002060228	300002060230	1
30	Shield Cover of Electric Box Cover	01592150	01592150	01592150	1
31	Electric Box Cover Sub-Assy	0140206501	0140206501	0140206501	1
32	Electric Box Cover	20112207	20112207	2011220701	1
33	Power Cord	/	/	/	/
34	Connecting Cable	4002052317	4002052317	4002052317	0
35	Connecting Cable	/	/	/	/
36	Remote Controller	305001060023	305001060023	305001060023	1
37	Cold Plasma Generator	1114001603	1114001603	1114001603	1
38	Detecting Plate	30110154	30110154	30110144	1

Above data is subject to change without notice.

NO.	Description	Part Code		Qty
		GWH12QC-K6DNC6D/I	GWH09QB-K6DNC6E/I	
	Product Code	CB443N05700	CB443N06000	
1	Front Panel Assy	20000300102T	20000300101T	1
2	Display Board	30565260	30565260	1
3	Front Case Assy	00000200045	00000200040	1
4	Guide Louver	1051293101	1051276301	1
5	Air Louver 2	10512725	10512720	1
6	Swing Lever	10582459	10582460	1
7	Helicoid Tongue	26112436	26112508	1
8	Rear Case	00000100092	2220255501	1
9	Drainage Hose	05230014	0523001408	1
10	Ring of Bearing	26152022	26152022	1
11	O-Gasket sub-assy of Bearing	76512051	76512051	1
12	Evaporator Support	24212179	24212180	1
13	Evaporator Assy	011001060162	0110010009505	1
14	Wall Mounting Frame	01252484	01252043	1
15	Cross Flow Fan	10352056	10352059	1
16	Motor Press Plate	26112516	26112373	1
17	Fan Motor	1501214606	150120874	1
18	Connecting pipe clamp	2611216401	2611216401	1
19	Rubber Plug (Water Tray)	76712012	76712012	1
20	Stepping Motor	1521210108	1521210704	1
21	Crank	73012005	73012005	1
22	Stepping Motor	1521210710	1521212901	1
23	Air Louver 3	10512726	10512739	1
24	Electric Box Assy	100002062937	100002062070	1
25	Air Louver 1	10512727	10512740	1
26	Axile Bush	10542036	10542036	1
27	Terminal Board	42011233	42011233	1
28	Jumper	4202021917	4202021908	1
29	Main Board	300002060234	300002060229	1
30	Shield Cover of Electric Box Cover	01592150	01592150	1
31	Electric Box Cover Sub-Assy	0140206501	0140206501	1
32	Electric Box Cover	2011220701	20112207	1
33	Power Cord	/	/	/
34	Connecting Cable	4002052317	4002052317	0
35	Connecting Cable	/	/	/
36	Remote Controller	305001060023	305001060023	1
37	Cold Plasma Generator	/	/	/
38	Detecting Plate	30110144	30110154	1

Above data is subject to change without notice.

NO.	Description			Qty
		GWH09QC-K6DNC2A/I	GWH12QC-K6DNC2A/I	
	Product Code	CB439N14100	CB439N14200	
1	Front Panel Assy	20000300069S	20000300069S	1
2	Display Board	30565281	30565281	1
3	Front Case Assy	00000200045	00000200045	1
4	Guide Louver	1051293101	1051293101	1
5	Air Louver 2	10512725	10512725	1
6	Swing Lever	10582459	10582459	1
7	Helicoid Tongue	26112436	26112436	1
8	Rear Case	2220255401	2220255401	1
9	Drainage Hose	05230014	05230014	1
10	Ring of Bearing	26152022	26152022	1
11	O-Gasket sub-assy of Bearing	76512051	76512051	1
12	Evaporator Support	24212179	24212179	1
13	Evaporator Assy	0100297604	0100297604	1
14	Wall Mounting Frame	01252484	01252484	1
15	Cross Flow Fan	10352056	10352056	1
16	Motor Press Plate	26112516	26112516	1
17	Fan Motor	1501246601	1501246601	1
18	Connecting pipe clamp	2611216401	2611216401	1
19	Rubber Plug (Water Tray)	76712012	76712012	1
20	Stepping Motor	1521210710	1521210710	1
21	Crank	73012005	73012005	1
22	Stepping Motor	1521210108	1521210108	1
23	Air Louver 3	10512727	10512727	1
24	Electric Box Assy	100002065288	100002065291	1
25	Air Louver 1	10512726	10512726	1
26	Axile Bush	10542036	10542036	1
27	Terminal Board	42011233	42011233	1
28	Jumper	4202021909	4202021920	1
29	Main Board	300002060785	300002060785	1
30	Shield Cover of Electric Box Cover	01592150	01592150	1
31	Electric Box Cover Sub-Assy	0140206501	0140206501	1
32	Electric Box Cover	2011220701	2011220701	1
33	Power Cord	/	/	/
34	Connecting Cable	4002052317	4002052317	0
35	Connecting Cable	/	/	/
36	Remote Controller	305001000081	305001000081	1
37	Cold Plasma Generator	1114001606	1114001606	1
38	Detecting Plate	30110144	30110144	1

Above data is subject to change without notice.

NO.	Description	Part Code			Qty
		GWH12QC-K6DNB8D/I	GWH09QB-K6DNA3E/I	GWH12QC-K6DNA3D/I	
	Product Code	CB438N10201	CB424N08000	CB424N08200	
1	Front Panel Assy	20000300074	00000300172	00000300177	1
2	Display Board	30565260	300001060081	30565263	1
3	Front Case Assy	00000200045	00000200119	00000200109	1
4	Guide Louver	1051293101	1051272202	1051249202	1
5	Air Louver 2	10512725	10512720	10512725	1
6	Swing Lever	10582459	10582460	10582459	1
7	Helicoid Tongue	26112436	26112508	26112436	1
8	Rear Case	2220255401	2220255501	2220255401	1
9	Drainage Hose	05230014	0523001408	05230014	1
10	Ring of Bearing	26152022	26152022	26152022	1
11	O-Gasket sub-assy of Bearing	76512051	76512051	76512051	1
12	Evaporator Support	24212179	24212180	24212179	1
13	Evaporator Assy	01100106016201	0110010009505	011001060162	1
14	Wall Mounting Frame	01252484	01252043	01252484	1
15	Cross Flow Fan	10352056	10352059	10352056	1
16	Motor Press Plate	26112516	26112373	26112516	1
17	Fan Motor	1501214606	150120874	1501214606	1
18	Connecting pipe clamp	2611216401	2611216401	2611216401	1
19	Rubber Plug (Water Tray)	76712012	76712012	76712012	1
20	Stepping Motor	1521210108	1521212901	1521210108	1
21	Crank	73012005	73012005	73012005	1
22	Stepping Motor	1521210710	1521212901	1521210710	1
23	Air Louver 3	10512726	10512739	10512726	1
24	Electric Box Assy	100002060206	100002066527	100002066528	1
25	Air Louver 1	10512727	1051272202	10512727	1
26	Axile Bush	10542036	10542036	10542036	1
27	Terminal Board	42011233	42011233	42011233	1
28	Jumper	4202021917	4202021902	4202021906	1
29	Main Board	300002060230	300002060228	300002060230	1
30	Shield Cover of Electric Box Cover	01592150	01592150	01592150	1
31	Electric Box Cover Sub-Assy	0140206501	0140206501	0140206501	1
32	Electric Box Cover	2011220701	20112207	2011220701	1
33	Power Cord	/	/	/	/
34	Connecting Cable	4002052317	4002052317	4002052317	0
35	Connecting Cable	/	/	/	/
36	Remote Controller	305001060023	305001060023	305001060023	1
37	Cold Plasma Generator	1114001605	1114001605	1114001605	1
38	Detecting Plate	30110144	30110154	30110144	1

Above data is subject to change without notice.

NO.	Description	Part Code			Qty
		GWH09QB-K6DND6E/I	GWH12QC-K6DNB2D/I	GWH09QB-K6DNB2E/I	
	Product Code	CB460N05900	CB432N17802	CB432N17602	
1	Front Panel Assy	200003000028S	20000300018S	20000300019S	1
2	Display Board	300001000041	30565260	30565260	1
3	Front Case Assy	00000200040	00000200045	00000200040	1
4	Guide Louver	1051276301	1051293101	1051276301	1
5	Air Louver 2	10512720	10512725	10512720	1
6	Swing Lever	10582460	10582459	10582460	1
7	Helicoid Tongue	26112508	26112436	26112508	1
8	Rear Case	2220255501	2220255401	2220255501	1
9	Drainage Hose	0523001408	05230014	0523001408	1
10	Ring of Bearing	26152022	26152022	26152022	1
11	O-Gasket sub-assy of Bearing	76512051	76512051	76512051	1
12	Evaporator Support	24212180	24212179	24212180	1
13	Evaporator Assy	0110010009505	01100106016201	0110010009511	1
14	Wall Mounting Frame	01252043	01252484	01252043	1
15	Cross Flow Fan	10352059	10352056	10352059	1
16	Motor Press Plate	26112373	26112516	26112373	1
17	Fan Motor	150120874	1501214606	150120874	1
18	Connecting pipe clamp	2611216401	2611216401	2611216401	1
19	Rubber Plug (Water Tray)	76712012	76712012	76712012	1
20	Stepping Motor	1521212901	1521210108	1521212901	1
21	Crank	73012005	73012005	73012005	1
22	Stepping Motor	1521210704	1521210710	1521212901	1
23	Air Louver 3	10512739	10512726	10512739	1
24	Electric Box Assy	10000204857	100002060206	100002062339	1
25	Air Louver 1	10512740	10512727	10512740	1
26	Axile Bush	10542036	10542036	10542036	1
27	Terminal Board	42011233	42011233	42011233	1
28	Jumper	4202021908	4202021917	4202021908	1
29	Main Board	300002060228	300002060230	300002060228	1
30	Shield Cover of Electric Box Cover	01592150	01592150	01592150	1
31	Electric Box Cover Sub-Assy	0140206501	0140206501	0140206501	1
32	Electric Box Cover	20112207	2011220701	20112207	1
33	Power Cord	/	/	/	/
34	Connecting Cable	4002052317	4002052317	4002052317	0
35	Connecting Cable	/	/	/	/
36	Remote Controller	305001060023	305001060023	305001060023	1
37	Cold Plasma Generator	1114001605	1114001605	1114001605	1
38	Detecting Plate	30110154	30110144	30110154	1

Above data is subject to change without notice.

NO.	Description	Part Code			Qty
		GWH09QB-K6DND2E/I	GWH12QC-K6DND2D/I	GWH09QB-K6DND2E/I	
	Product Code	CB461N05800	CB461N05500	CB461N05802	
1	Front Panel Assy	00000300003202	200003000007	00000300003204	1
2	Display Board	30565281	30565281	30565308	1
3	Front Case Assy	00000200040	00000200045	000002000070	1
4	Guide Louver	1051276301	1051293101	1051276302P01	1
5	Air Louver 2	10512720	10512725	10512720	1
6	Swing Lever	10582460	10582459	10582460	1
7	Helicoid Tongue	26112508	26112436	26112508	1
8	Rear Case	2220255501	00000100092	2220255501	1
9	Drainage Hose	0523001408	05230014	0523001408	1
10	Ring of Bearing	26152022	26152022	26152022	1
11	O-Gasket sub-assy of Bearing	76512051	76512051	76512051	1
12	Evaporator Support	24212180	24212179	24212180	1
13	Evaporator Assy	0110010009505	011001060162	0110010009505	1
14	Wall Mounting Frame	01252043	01252484	01252043	1
15	Cross Flow Fan	10352059	10352056	10352059	1
16	Motor Press Plate	26112373	26112516	26112373	1
17	Fan Motor	150120874	1501214606	150120874	1
18	Connecting pipe clamp	2611216401	2611216401	2611216401	1
19	Rubber Plug (Water Tray)	76712012	76712012	76712012	1
20	Stepping Motor	1521210704	1521210108	1521210704	1
21	Crank	73012005	73012005	73012005	1
22	Stepping Motor	1521212901	1521210710	1521212901	1
23	Air Louver 3	10512739	10512726	10512739	1
24	Electric Box Assy	100002062338	10000204858	100002067946	1
25	Air Louver 1	10512740	10512740	10512740	1
26	Axile Bush	10542036	10542036	10542036	1
27	Terminal Board	42011233	42011233	42011233	1
28	Jumper	4202021908	4202021908	4202021908	1
29	Main Board	300002060228	300002060230	300002060228	1
30	Shield Cover of Electric Box Cover	01592150	01592150	01592150	1
31	Electric Box Cover Sub-Assy	0140206501	0140206501	0140206505	1
32	Electric Box Cover	20112207	2011220701	20112207	1
33	Power Cord	/	/	/	/
34	Connecting Cable	4002052317	4002052317	4002052317	0
35	Connecting Cable	/	/	/	/
36	Remote Controller	305001060023	305001060023	305001060023	1
37	Cold Plasma Generator	1114001605	1114001605	1114001605	1
38	Detecting Plate	30110154	30110144	30110154	1

Above data is subject to change without notice.

NO.	Description	Part Code			Qty
		GWH12QC-K6DND2D/I	GWH12QC-K6DND2D/I	GWH09QB-K6DND2E/I	
	Product Code	CB461N05501	CB461N05502	CB461N05801	
1	Front Panel Assy	20000300000701P01	20000300000701P	000003000003201	1
2	Display Board	30565308	300001000033	300001000033	1
3	Front Case Assy	00000200000703	00000200000701	00000200000601	1
4	Guide Louver	10512492	1051293102P	1051276302P	1
5	Air Louver 2	10512725	10512725	10512720	1
6	Swing Lever	10582459	10582459	10582460	1
7	Helicoid Tongue	26112436	26112436	26112508	1
8	Rear Case	00000100092	00000100092	2220255501	1
9	Drainage Hose	05230014	05230014	0523001408	1
10	Ring of Bearing	26152022	26152022	26152022	1
11	O-Gasket sub-assy of Bearing	76512051	76512051	76512051	1
12	Evaporator Support	24212179	24212179	24212180	1
13	Evaporator Assy	011001060162	011001060162	0110010009505	1
14	Wall Mounting Frame	01252484	01252484	01252043	1
15	Cross Flow Fan	10352056	10352056	10352059	1
16	Motor Press Plate	26112516	26112516	26112373	1
17	Fan Motor	1501214606	1501214606	150120874	1
18	Connecting pipe clamp	2611216401	2611216401	2611216401	1
19	Rubber Plug (Water Tray)	76712012	76712012	76712012	1
20	Stepping Motor	1521210108	1521210108	1521210704	1
21	Crank	73012005	73012005	73012005	1
22	Stepping Motor	1521210710	1521210710	1521212901	1
23	Air Louver 3	10512726	10512726	10512739	1
24	Electric Box Assy	100002067952	100002067948	100002067951	1
25	Air Louver 1	10512727	10512727	10512740	1
26	Axile Bush	10542036	10542036	10542036	1
27	Terminal Board	42011233	42011233	42011233	1
28	Jumper	4202021917	4202021917	4202021908	1
29	Main Board	300002060230	300002060230	300002060228	1
30	Shield Cover of Electric Box Cover	01592150	01592150	01592150	1
31	Electric Box Cover Sub-Assy	0140206505	0140206504	0140206504	1
32	Electric Box Cover	2011220701	2011220701	20112207	1
33	Power Cord	/	/	/	/
34	Connecting Cable	4002052317	4002052317	4002052317	0
35	Connecting Cable	/	/	/	/
36	Remote Controller	305001060023	305001060023	305001060023	1
37	Cold Plasma Generator	1114001605	1114001605	1114001605	1
38	Detecting Plate	30110144	30110144	30110154	1

Above data is subject to change without notice.

NO.	Description	Part Code			Qty
		GWH12QC-K6DNC8D/I	GWH09QB-K6DNB2E/I	GWH12QC-K6DNB2D/I	
	Product Code	CB456N07100	CB432N17601	CB432N17801	
1	Front Panel Assy	20000300154T	20000300019S	20000300018S	1
2	Display Board	30565281	30565260	30565260	1
3	Front Case Assy	00000200045	00000200040	00000200045	1
4	Guide Louver	1051293101	1051276301	1051293101	1
5	Air Louver 2	10512725	10512720	10512725	1
6	Swing Lever	10582459	10582460	10582459	1
7	Helicoid Tongue	26112436	26112508	26112436	1
8	Rear Case	00000100092	2220255501	00000100092	1
9	Drainage Hose	05230014	0523001408	05230014	1
10	Ring of Bearing	26152022	26152022	26152022	1
11	O-Gasket sub-assy of Bearing	76512051	76512051	76512051	1
12	Evaporator Support	24212179	24212180	24212179	1
13	Evaporator Assy	011001060162	0110010009505	011001060162	1
14	Wall Mounting Frame	01252484	01252043	01252484	1
15	Cross Flow Fan	10352056	10352059	10352056	1
16	Motor Press Plate	26112516	26112373	26112516	1
17	Fan Motor	1501214606	150120874	1501214606	1
18	Connecting pipe clamp	2611216401	2611216401	2611216401	1
19	Rubber Plug (Water Tray)	76712012	76712012	76712012	1
20	Stepping Motor	1521210108	1521210704	1521210108	1
21	Crank	73012005	73012005	73012005	1
22	Stepping Motor	1521210710	1521210704	1521210108	1
23	Air Louver 3	10512726	10512739	10512726	1
24	Electric Box Assy	10000204858	100002062070	100002062937	1
25	Air Louver 1	10512727	10512740	10512727	1
26	Axile Bush	10542036	10542036	10542036	1
27	Terminal Board	42011233	42011233	42011233	1
28	Jumper	4202021917	4202021908	4202021917	1
29	Main Board	300002060230	300002060229	300002060234	1
30	Shield Cover of Electric Box Cover	01592150	01592150	01592150	1
31	Electric Box Cover Sub-Assy	0140206501	0140206501	0140206501	1
32	Electric Box Cover	2011220701	20112207	2011220701	1
33	Power Cord	/	/	/	/
34	Connecting Cable	4002052317	4002052317	4002052317	0
35	Connecting Cable	/	/	/	/
36	Remote Controller	305001060023	305001060023	305001060023	1
37	Cold Plasma Generator	1114001605	/	/	1
38	Detecting Plate	30110144	30110154	30110144	1

Above data is subject to change without notice.

NO.	Description	Part Code			Qty
		GWH12QC-K6DND6D/I	GWH09QB-K6DNB4E/I	GWH12QC-K6DNB4D/I	
	Product Code	CB460N06700	CB434N12302	CB434N12601	
1	Front Panel Assy	200003000029S	200003000026T	200003000027T	1
2	Display Board	300001000041	30565260	30565260	1
3	Front Case Assy	00000200045	00000200040	00000200045	1
4	Guide Louver	1051293101	1051276301	1051293101	1
5	Air Louver 2	10512725	10512720	10512725	1
6	Swing Lever	10582459	10582460	10582459	1
7	Helicoid Tongue	26112436	26112508	26112436	1
8	Rear Case	00000100092	2220255501	00000100092	1
9	Drainage Hose	05230014	0523001408	05230014	1
10	Ring of Bearing	26152022	26152022	26152022	1
11	O-Gasket sub-assy of Bearing	76512051	76512051	76512051	1
12	Evaporator Support	24212179	24212180	24212179	1
13	Evaporator Assy	011001060162	0110010009505	011001060162	1
14	Wall Mounting Frame	01252484	01252043	01252484	1
15	Cross Flow Fan	10352056	10352059	10352056	1
16	Motor Press Plate	26112516	26112373	26112516	1
17	Fan Motor	1501214606	150120874	1501214606	1
18	Connecting pipe clamp	2611216401	2611216401	2611216401	1
19	Rubber Plug (Water Tray)	76712012	76712012	76712012	1
20	Stepping Motor	1521210108	1521210704	1521210108	1
21	Crank	73012005	73012005	73012005	1
22	Stepping Motor	1521210710	1521212901	1521210710	1
23	Air Louver 3	10512726	10512739	10512726	1
24	Electric Box Assy	100002068620	100002062070	100002062937	1
25	Air Louver 1	10512727	10512740	10512727	1
26	Axile Bush	10542036	10542036	10542036	1
27	Terminal Board	42011233	42011233	42011233	1
28	Jumper	4202021917	4202021908	4202021917	1
29	Main Board	300002060230	300002060229	300002060234	1
30	Shield Cover of Electric Box Cover	01592150	01592150	01592150	1
31	Electric Box Cover Sub-Assy	0140206501	017053060075	01705306007501	1
32	Electric Box Cover	2011220701	20112207	2011220701	1
33	Power Cord	/	/	/	/
34	Connecting Cable	4002052317	4002052317	4002052317	0
35	Connecting Cable	/	/	/	/
36	Remote Controller	305001060023	305001060023	305001060023	1
37	Cold Plasma Generator	1114001605	/	/	1
38	Detecting Plate	30110144	30110154	30110144	1

Above data is subject to change without notice.

NO.	Description	Part Code		Qty
		GWH09QB-K6DNC6E/I	GWH12QC-K6DNC6D/I	
	Product Code	CB443N06002	CB443N05702	
1	Front Panel Assy	20000300101	20000300102T	1
2	Display Board	30565260	30565260	1
3	Front Case Assy	00000200040	00000200045	1
4	Guide Louver	1051276301	1051293101	1
5	Air Louver 2	10512720	10512725	1
6	Swing Lever	10582460	10582459	1
7	Helicoid Tongue	26112508	26112436	1
8	Rear Case	2220255501	00000100092	1
9	Drainage Hose	0523001408	05230014	1
10	Ring of Bearing	26152022	26152022	1
11	O-Gasket sub-assy of Bearing	76512051	76512051	1
12	Evaporator Support	24212180	24212179	1
13	Evaporator Assy	0110010009505	011001060162	1
14	Wall Mounting Frame	01252043	01252484	1
15	Cross Flow Fan	10352059	10352056	1
16	Motor Press Plate	26112373	26112516	1
17	Fan Motor	150120874	1501214606	1
18	Connecting pipe clamp	2611216401	2611216401	1
19	Rubber Plug (Water Tray)	76712012	76712012	1
20	Stepping Motor	1521212901	1521210108	1
21	Crank	73012005	73012005	1
22	Stepping Motor	1521212901	1521210108	1
23	Air Louver 3	10512739	10512726	1
24	Electric Box Assy	100002062339	100002060206	1
25	Air Louver 1	10512740	10512727	1
26	Axile Bush	10542036	10542036	1
27	Terminal Board	42011233	42011233	1
28	Jumper	4202021908	4202021917	1
29	Main Board	300002060228	300002060230	1
30	Shield Cover of Electric Box Cover	01592150	01592150	1
31	Electric Box Cover Sub-Assy	017053060075	01705306007501	1
32	Electric Box Cover	20112207	2011220701	1
33	Power Cord	/	/	/
34	Connecting Cable	4002052317	4002052317	0
35	Connecting Cable	/	/	/
36	Remote Controller	305001060023	305001060023	1
37	Cold Plasma Generator	1114001605	1114001605	1
38	Detecting Plate	30110154	30110144	1

Above data is subject to change without notice.

NO.	Description	Part Code			Qty
		GWH09QB-K6DNB8E/I	GWH12QC-K6DNB8D/I	GWH12QC-K6DNA5X/I	
	Product Code	CB438N10101	CB438N10202	CB425N15500	
1	Front Panel Assy	20000300073T	20000300074T	00000300022	1
2	Display Board	30565260	30565260	30565260	1
3	Front Case Assy	00000200040	00000200045	00000200022	1
4	Guide Louver	1051276301	1051293101	1051249202	1
5	Air Louver 2	10512720	10512725	10512725	1
6	Swing Lever	10582460	10582459	10582459	1
7	Helicoid Tongue	26112508	26112436	26112436	1
8	Rear Case	2220255501	2220255401	00000100092	1
9	Drainage Hose	0523001408	05230014	05230014	1
10	Ring of Bearing	26152022	26152022	26152022	1
11	O-Gasket sub-assy of Bearing	76512051	76512051	76512051	1
12	Evaporator Support	24212180	24212179	24212179	1
13	Evaporator Assy	0110010009505	011001060162	011001060162	1
14	Wall Mounting Frame	01252043	01252484	01252484	1
15	Cross Flow Fan	10352059	10352056	10352056	1
16	Motor Press Plate	26112373	26112516	26112516	1
17	Fan Motor	150120874	1501214606	1501214606	1
18	Connecting pipe clamp	2611216401	2611216401	2611216401	1
19	Rubber Plug (Water Tray)	76712012	76712012	76712012	1
20	Stepping Motor	1521210704	1521210108	1521210108	1
21	Crank	73012005	73012005	73012005	1
22	Stepping Motor	1521210704	1521210108	1521210108	1
23	Air Louver 3	10512739	10512726	10512726	1
24	Electric Box Assy	100002062070	100002062937	10000204671	1
25	Air Louver 1	10512740	10512727	10512727	1
26	Axile Bush	10542036	10542036	10542036	1
27	Terminal Board	42011233	42011233	42011233	1
28	Jumper	4202021908	4202021917	4202021906	1
29	Main Board	300002060229	300002060234	300002060230	1
30	Shield Cover of Electric Box Cover	01592150	01592150	01592150	1
31	Electric Box Cover Sub-Assy	017053060075	01705306007501	01705306007501	1
32	Electric Box Cover	20112207	2011220701	2011220701	1
33	Power Cord	/	/	/	/
34	Connecting Cable	4002052317	4002052317	4002052317	0
35	Connecting Cable	/	/	/	/
36	Remote Controller	305001060023	305001060023	305001060023	1
37	Cold Plasma Generator	/	/	1114001605	1
38	Detecting Plate	30110154	30110144	30110144	1

Above data is subject to change without notice.

NO.	Description	Part Code		Qty
		GWH09QC-K6DND2A/I	GWH12QC-K6DND2A/I	
		Product Code	Product Code	
		CB461N06600	CB461N06500	
1	Front Panel Assy	00000300003305	00000300003305	1
2	Display Board	30565308	30565308	1
3	Front Case Assy	00000200000703	00000200000703	1
4	Guide Louver	1051293102P01	1051293102P01	1
5	Air Louver 2	10512725	10512725	1
6	Swing Lever	10582459	10582459	1
7	Helicoid Tongue	26112436	26112436	1
8	Rear Case	00000100092	00000100092	1
9	Drainage Hose	05230014	05230014	1
10	Ring of Bearing	26152022	26152022	1
11	O-Gasket sub-assy of Bearing	76512051	76512051	1
12	Evaporator Support	24212179	24212179	1
13	Evaporator Assy	0100297604	0100297604	1
14	Wall Mounting Frame	01252484	01252484	1
15	Cross Flow Fan	10352056	10352056	1
16	Motor Press Plate	26112516	26112516	1
17	Fan Motor	150104060029	150104060029	1
18	Connecting pipe clamp	2611216401	2611216401	1
19	Rubber Plug (Water Tray)	76712012	76712012	1
20	Stepping Motor	1521210108	1521210108	1
21	Crank	73012005	73012005	1
22	Stepping Motor	1521210710	1521210710	1
23	Air Louver 3	10512726	10512726	1
24	Electric Box Assy	100002071238	100002071241	1
25	Air Louver 1	10512727	10512727	1
26	Axile Bush	10542036	10542036	1
27	Terminal Board	42011233	42011233	1
28	Jumper	4202021909	4202021920	1
29	Main Board	300002060785	300002060785	1
30	Shield Cover of Electric Box Cover	01592150	01592150	1
31	Electric Box Cover Sub-Assy	01705306007501	01705306007501	1
32	Electric Box Cover	2011220701	2011220701	1
33	Power Cord	/	/	/
34	Connecting Cable	4002052317	4002052317	0
35	Connecting Cable	/	/	/
36	Remote Controller	305001000081	305001000081	1
37	Cold Plasma Generator	1114001606	1114001606	1
38	Detecting Plate	30110144	30110144	1

Above data is subject to change without notice.

09/12K For some models

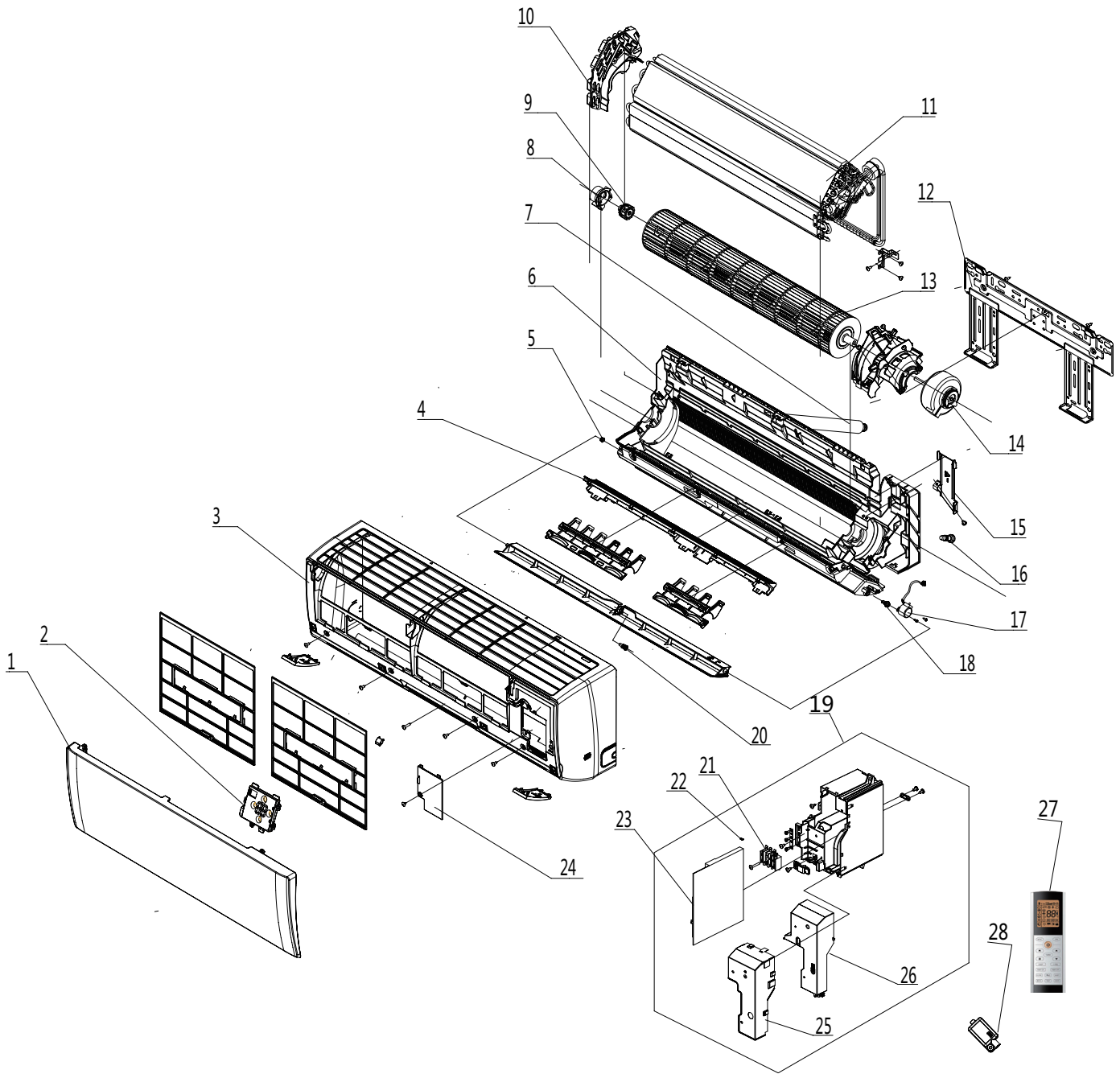

The component picture is only for reference; please refer to the actual product.

No.	Description	Part Code			Qty
		GWH09QB-K6DNC4E/I	GWH12QC-K6DNE4D/I	GWH09QB-K6DNE4E/I	
	Product Code	CB444N09602	CB434N04404	CB470N02702	
1	Front Panel	20000300105S	20000300026T	200003000065	1
2	Display Board	30565260	30565260	300001000081	2
3	Front Case Assy	00000200040	00000200040	00000200040	1
4	Helicoid Tongue	26112508	26112508	26112508	1
5	Left Axile Bush	10512037	10512037	10512037	1
6	Rear Case assy	20162010	20162010	20162010	1
7	Drainage Hose	0523001408	0523001408	0523001408	1
8	Ring of Bearing	26152022	26152022	26152022	1
9	O-Gasket sub-assy of Bearing	76512051	76512051	76512051	1
10	Evaporator Support	24212180	24212180	24212180	1
11	Evaporator Assy	0110010009505	0100200004406	0110010009505	1
12	Wall Mounting Frame	01252043	01252043	01252043	1
13	Fan Motor	150120874	150120874	150120874	1
14	Cross Flow Fan	10352059	10352059	10352059	1
15	Connecting pipe clamp	2611216401	2611216401	2611216401	1
16	Rubber Plug (Water Tray)	76712012	76712012	76712012	1
17	Stepping Motor	1521212901	1521212901	1521212901	1
18	Crank	73012005	73012005	73012005	1
19	Electric Box Assy	100002062965	100002064663	100002062907	1
20	Axile Bush	10542036	10542036	10542036	1
21	Terminal Board	42011233	42011233	42011233	1
22	Jumper	4202021908	4202021911	4202021908	1
23	Main Board	300002060467	300002060730	300002060467	1
24	Electric Box Cover Sub-Assy	0140206501	0140206501	0140206501	1
25	Shield Cover of Electric Box Cover	01592150	01592150	01592150	1
26	Electric Box Cover	20112207	20112207	20112207	1
27	Remote Controller	305001060023	305001000087	305001060023	1
28	Detecting Plate	30110154	30110154	30110154	1

Above data is subject to change without notice.

No.	Description	Part Code			Qty
		GWH09QB-K6DNA5E/I	GWH12QC-K6DNA5D/I	GWH09QB-K6DNA2E/I	
		Product Code	CB425N12502	CB425N12302	
1	Front Panel	2002267001	2002269402S	20022719	1
2	Display Board	30565260	30565260	300001060082	2
3	Front Case Assy	2002249501	00000200022	2002273001	1
4	Helicoid Tongue	26112508	26112436	26112508	1
5	Left Axile Bush	10512037	10512037	10512037	1
6	Rear Case assy	20162010	00000100093	20162010	1
7	Drainage Hose	0523001408	05230014	0523001408	1
8	Ring of Bearing	26152022	26152022	26152022	1
9	O-Gasket sub-assy of Bearing	76512051	76512051	76512051	1
10	Evaporator Support	24212180	24212179	24212180	1
11	Evaporator Assy	0110010009505	011001060162	0110010009505	1
12	Wall Mounting Frame	01252043	01252484	01252043	1
13	Fan Motor	150120874	1501214606	150120874	1
14	Cross Flow Fan	10352059	10352056	10352059	1
15	Connecting pipe clamp	2611216401	2611216401	2611216401	1
16	Rubber Plug (Water Tray)	76712012	76712012	76712012	1
17	Stepping Motor	1521212901	1521210710	1521212901	1
18	Crank	73012005	73012005	73012005	1
19	Electric Box Assy	100002065976	100002065977	100002069068	1
20	Axile Bush	10542036	10542036	10542036	1
21	Terminal Board	42011233	42011233	42011233	1
22	Jumper	4202021902	4202021906	4202021908	1
23	Main Board	300002060467	300002060466	300002060467	1
24	Electric Box Cover Sub-Assy	0140206501	0140206501	017053060075	1
25	Shield Cover of Electric Box Cover	01592150	01592150	01592150	1
26	Electric Box Cover	20112207	2011220701	20112207	1
27	Remote Controller	305001060023	305001060023	305001060023	1
28	Detecting Plate	30110154	30110144	30110154	1

Above data is subject to change without notice.

No.	Description	Part Code		
		GWH12QB-K6DNB2A/I		
		CB432N25500		
Qty				
1	Front Panel	20000300019S		1
2	Display Board	30565260		2
3	Front Case Assy	00000200040		1
4	Helicoid Tongue	26112508		1
5	Left Axile Bush	10512037		1
6	Rear Case assy	20162010		1
7	Drainage Hose	0523001408		1
8	Ring of Bearing	26152022		1
9	O-Gasket sub-assy of Bearing	76512051		1
10	Evaporator Support	24212180		1
11	Evaporator Assy	0110010009514		1
12	Wall Mounting Frame	01252043		1
13	Fan Motor	150120874		1
14	Cross Flow Fan	10352059		1
15	Connecting pipe clamp	2611216401		1
16	Rubber Plug (Water Tray)	76712012		1
17	Stepping Motor	1521212901		1
18	Crank	73012005		1
19	Electric Box Assy	100002071056		1
20	Axile Bush	10542036		1
21	Terminal Board	42011233		1
22	Jumper	4202021911		1
23	Main Board	300002062057		1
24	Electric Box Cover Sub-Assy	017053060075		1
25	Shield Cover of Electric Box Cover	01592150		1
26	Electric Box Cover	20112207		1
27	Remote Controller	305001000087		1
28	Detecting Plate	30110154		1

Above data is subject to change without notice.

QA

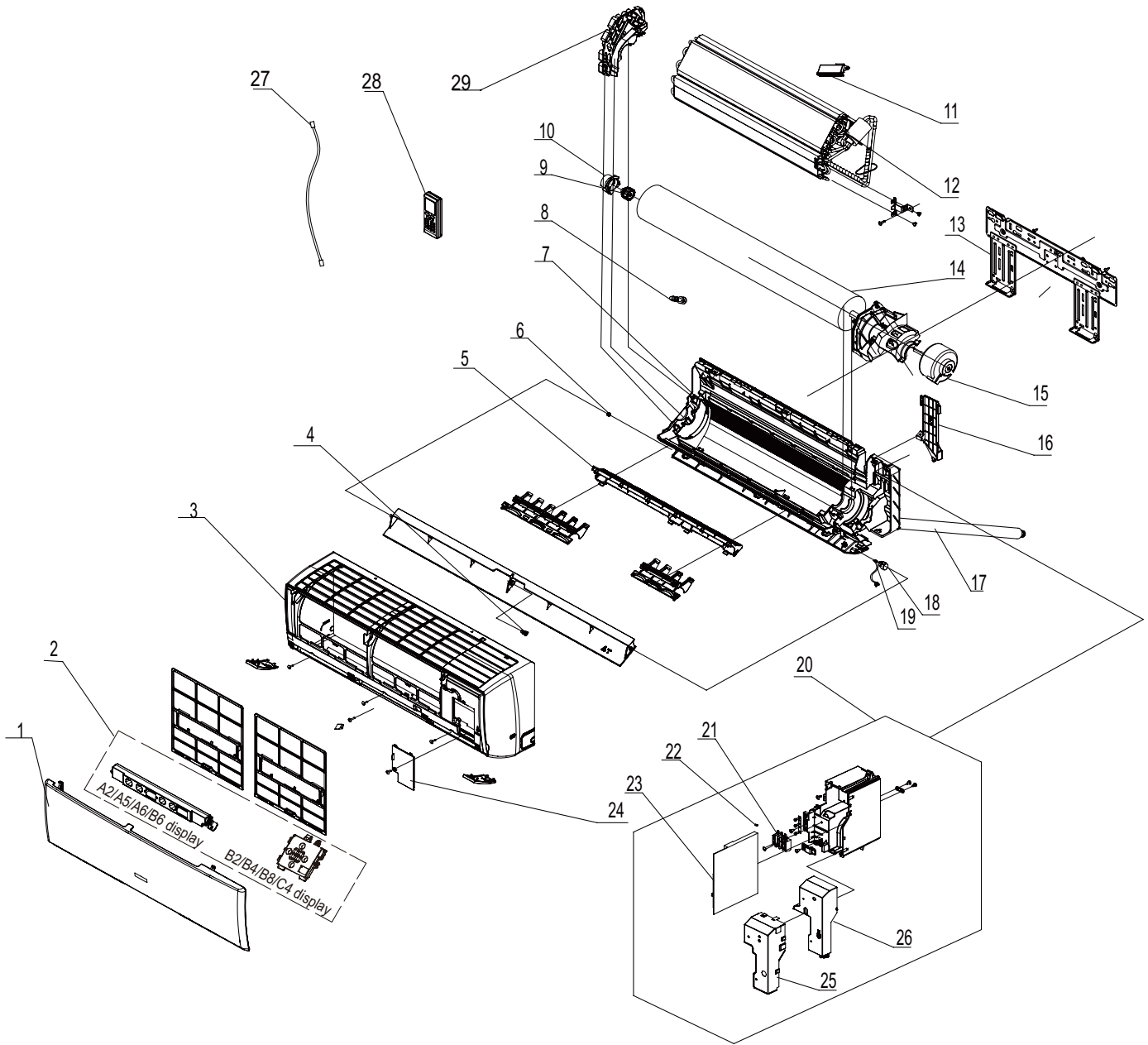

The component picture is only for reference; please refer to the actual product.

No.	Description	Part Code	Qty
		GWH09QA-K6DNB2A/I	
Product Code		CB432N25400	
1	Front Panel Assy	20000300021S	1
2	Display Board	30565260	1
3	Front Case Assy	00000200041	1
4	Axile Bush	10542036	1
5	Helicoid Tongue	26112509	1
6	Left Axile Bush	10512037	1
7	Rear Case assy	20022732	1
8	Rubber Plug (Water Tray)	76712012	1
9	O-Gasket sub-assy of Bearing	76512051	1
10	Ring of Bearing	26152022	1
11	Cold Plasma Generator	/	1
12	Evaporator Assy	0100297201	1
13	Wall Mounting Frame	01363013	1
14	Cross Flow Fan	10352058	1
15	Fan Motor	15012115	1
16	Connecting pipe clamp	2611216401	1
17	Drainage Hose	0523001408	1
18	Stepping Motor	1521212901	1
19	Crank	73012005	1
20	Electric Box Assy	100002071677	1
21	Terminal Board	42011233	1
22	Jumper	4202021929	1
23	Main Board	300002062025	1
24	Electric Box Cover Sub-Assy	017053060075	1
25	Shield Cover of Electric Box Cover	01592150	1
26	Electric Box Cover	20112207	1
27	Connecting Cable	4002052317	0
28	Remote Controller	305001000087	1
29	Evaporator Support	24212180	1

Above data is subject to change without notice.

18K For some models

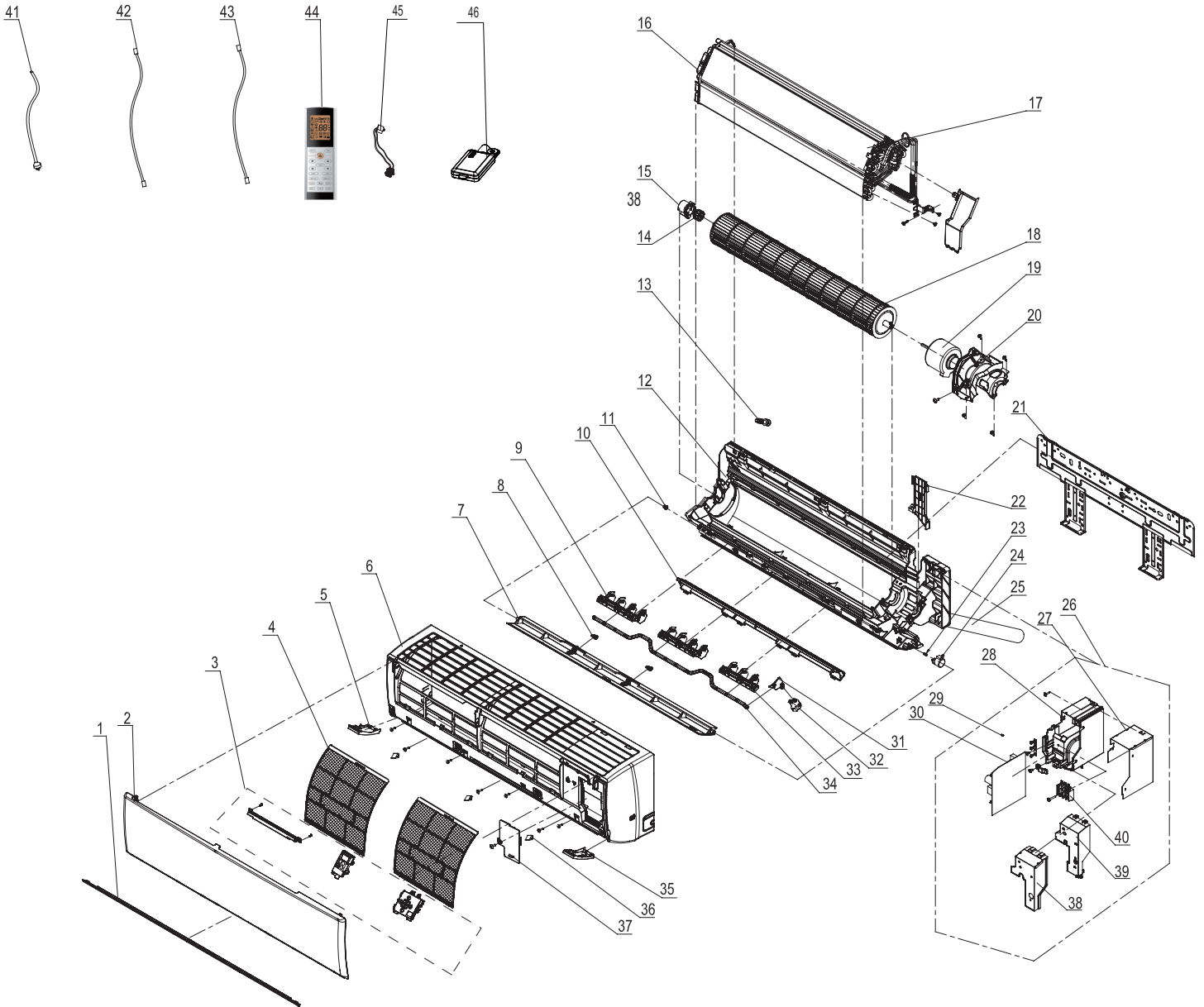

The component picture is only for reference; please refer to the actual product.

No.	Description	Part Code			Qty
		GWH18QD-K6DNA1D/I	GWH18QD-K6DNB6D/I	GWH18QD-K6DNE4D/I	
	Product Code	CB419N15600	CB435N09500	CB470N03000	
1	Decorative Strip	20192613	/	/	1
2	Front Panel Assy	20022490	20000300040T	200003000064T	1
3	Display Board	30565233	30565278	300001000081	1
4	Filter Sub-Assy	1112208906	1112208906	1112208906	2
5	Decorative Board (Left)	20192612	20192662	20192662	1
6	Front Case	20022484	2002248401	2002248401	1
7	Guide Louver	10512734	1051276501	1051276501	1
8	Axile Bush	10542036	10542036	10542036	2
9	Air Louver 1	10512733	10512733	10512733	2
10	Helicoid tongue	26112512	26112512	26112512	1
11	Left Axile Bush	10512037	10512037	10512037	1
12	Rear Case assy	00000100001	00000100001	00000100001	1
13	Rubber Plug (Water Tray)	76712012	76712012	76712012	1
14	O-Gasket sub-assy of Bearing	7651205102	76512051	76512051	1
15	Ring of Bearing	26152025	26152025	26152025	1
16	Evaporator Support	24212177	24212177	24212177	1
17	Evaporator Assy	011001000207	011001000207	011001000207	1
18	Cross Flow Fan	10352060	10352060	10352060	1
19	Fan Motor	1501214502	1501214502	1501214502	1
20	Motor Press Plate	26112511	26112511	26112511	1
21	Wall Mounting Frame	01362026	01362026	01362026	1
22	Connecting pipe clamp	2611218801	2611218801	2611218801	1
23	Crank	73012005	73012005	73012005	1
24	Stepping Motor	1521240212	1521240212	1521240212	1
25	Drainage hose	05230014	05230014	05230014	1
26	Electric Box Assy	100002061307	100002062363	100002062372	1
27	Lower Shield of Electric Box	01592139	01592139	01592139	1
28	Electric Box	20112211	20112211	20112211	1
29	Jumper	4202021912	4202021921	4202021921	1
30	Main Board	300002060236	300002060236	300002060236	1
31	Air Louver	10512736	10512736	10512736	1
32	Stepping Motor	1521210704	1521210704	1521210704	1
33	Air Louver 2	10512735	10512735	01592176	1
34	Swing Lever	10512731	10512731	10512731	1
35	Decorative Board (Right)	20192611	/	/	1
36	Screw Cover	242520179	2425201726	2425201726	3
37	Electric Box Cover2	20112210	20112210	20112210	1
38	Shield Cover of Electric Box	01592176	01592176	01592176	1
39	Electric Box Cover	20112209	20112209	20112209	1
40	Terminal Board	42011233	42011233	42011233	1
41	Power Cord	/	/	/	/
42	Connecting Cable	4002052317	4002052317	4002052317	0
43	Connecting Cable	/	/	/	/
44	Remote Controller	305001060023	305001060023	305001060023	1
45	Cold Plasma Generator	1114001602	1114001602	1114001602	1
46	Detecting Plate	30110144	30110144	30110144	1

Above data is subject to change without notice.

No.	Description	Part Code			Qty
		GWH18QD-K6DNC2E/I	GWH18QD-K6DNB2D/I	GWH18QD-K6DNB4D/I	
	Product Code	CB439N13200	CB432N17900	CB434N12500	
1	Decorative Strip	/	/	/	1
2	Front Panel Assy	20000300070S	20000300023	20000300028T	1
3	Display Board	30565278	30565260	30565260	1
4	Filter Sub-Assy	1112208906	1112208906	1112208906	2
5	Decorative Board (Left)	20192662	20192662	20192662	1
6	Front Case	2002248401	2002248401	2002248401	1
7	Guide Louver	1051276501	1051276501	1051276501	1
8	Axile Bush	10542036	10542036	10542036	2
9	Air Louver 1	10512733	10512733	10512733	2
10	Helicoid tongue	26112512	26112512	26112512	1
11	Left Axile Bush	10512037	10512037	10512037	1
12	Rear Case assy	00000100001	00000100001	00000100001	1
13	Rubber Plug (Water Tray)	76712012	76712012	76712012	1
14	O-Gasket sub-assy of Bearing	76512051	76512051	76512051	1
15	Ring of Bearing	26152025	26152025	26152025	1
16	Evaporator Support	24212177	24212177	24212177	1
17	Evaporator Assy	011001000207	011001000207	011001000207	1
18	Cross Flow Fan	10352060	10352060	10352060	1
19	Fan Motor	1501214502	1501214502	1501214502	1
20	Motor Press Plate	26112511	26112511	26112511	1
21	Wall Mounting Frame	01362026	01362026	01362026	1
22	Connecting pipe clamp	2611218801	2611218801	2611218801	1
23	Crank	73012005	73012005	73012005	1
24	Stepping Motor	1521240212	1521240212	1521240212	1
25	Drainage hose	05230014	05230014	05230014	1
26	Electric Box Assy	100002062363	100002062374	100002062374	1
27	Lower Shield of Electric Box	01592139	01592139	01592139	1
28	Electric Box	20112211	2011221104	20112211	1
29	Jumper	4202021921	4202021921	4202021921	1
30	Main Board	300002060236	300002060236	300002060236	1
31	Air Louver	10512736	10512736	10512736	1
32	Stepping Motor	1521210704	1521210704	1521210704	1
33	Air Louver 2	10512735	10512735	10512735	1
34	Swing Lever	10512731	10512731	10512731	1
35	Decorative Board (Right)	/	/	/	/
36	Screw Cover	2425201726	2425201726	2425201726	3
37	Electric Box Cover2	20112210	20112210	20112210	1
38	Shield Cover of Electric Box	01592176	01592176	01592176	1
39	Electric Box Cover	20112209	20112209	20112209	1
40	Terminal Board	42011233	42011233	42011233	1
41	Power Cord	/	/	/	/
42	Connecting Cable	4002052317	4002052317	4002052317	0
43	Connecting Cable	/	4002052317	/	/
44	Remote Controller	305001060023	305001060023	305001060023	1
45	Cold Plasma Generator	1114001602	1114001602	1114001602	1
46	Detecting Plate	30110144	30110144	30110144	1

Above data is subject to change without notice.

No.	Description	Part Code			Qty
		GWH18QD-K6DNA5D/I	GWH18QD-K6DNC6D/I	GWH18QD-K6DNB8D/I	
	Product Code	CB425N12400	CB443N05800	CB438N10300	
1	Decorative Strip	20192703P	/	/	1
2	Front Panel Assy	00000300035	20000300103T	20000300075T	1
3	Display Board	30565260	30565260	30565260	1
4	Filter Sub-Assy	1112208906	1112208906	1112208906	2
5	Decorative Board (Left)	2019261201	20192662	20192662	1
6	Front Case	2002248401	2002248401	2002248401	1
7	Guide Louver	1051273402	1051276501	1051276501	1
8	Axile Bush	10542036	10542036	10542036	2
9	Air Louver 1	10512733	10512733	10512733	2
10	Helicoid tongue	26112512	26112512	26112512	1
11	Left Axile Bush	10512037	10512037	10512037	1
12	Rear Case assy	00000100001	00000100001	00000100001	1
13	Rubber Plug (Water Tray)	76712012	76712012	76712012	1
14	O-Gasket sub-assy of Bearing	76512051	76512051	76512051	1
15	Ring of Bearing	26152025	26152025	26152025	1
16	Evaporator Support	24212177	24212177	24212177	1
17	Evaporator Assy	011001000207	011001000207	011001000207	1
18	Cross Flow Fan	10352060	10352060	10352060	1
19	Fan Motor	1501214502	1501214502	1501214502	1
20	Motor Press Plate	26112511	26112511	26112511	1
21	Wall Mounting Frame	01362026	01362026	01362026	1
22	Connecting pipe clamp	2611218801	2611218801	2611218801	1
23	Crank	73012005	73012005	73012005	1
24	Stepping Motor	1521240212	1521240212	1521240212	1
25	Drainage hose	05230014	05230014	05230014	1
26	Electric Box Assy	100002062364	100002062900	100002062374	1
27	Lower Shield of Electric Box	01592139	01592139	01592139	1
28	Electric Box	20112211	20112211	20112211	1
29	Jumper	4202021912	4202021921	4202021921	1
30	Main Board	300002060236	300002060243	300002060236	1
31	Air Louver	10512736	10512736	10512736	1
32	Stepping Motor	1521210704	1521210704	1521210704	1
33	Air Louver 2	10512735	10512735	10512735	1
34	Swing Lever	10512731	10512731	10512731	1
35	Decorative Board (Right)	2019261101	20192662	20192662	1
36	Screw Cover	2425201726	2425201726	2425201726	3
37	Electric Box Cover2	20112210	20112210	20112210	1
38	Shield Cover of Electric Box	01592176	01592176	01592176	1
39	Electric Box Cover	20112209	20112209	20112209	1
40	Terminal Board	42011233	42011233	42011233	1
41	Power Cord	/	/	/	/
42	Connecting Cable	4002052317	4002052317	4002052317	0
43	Connecting Cable	/	/	/	/
44	Remote Controller	305001060023	305001060023	305001060023	1
45	Cold Plasma Generator	1114001602	/	1114001602	1
46	Detecting Plate	30110144	30110144	30110144	1

Above data is subject to change without notice.

No.	Description	Part Code			Qty
		GWH18QD-K6DNC6D/I	GWH18QD-K6DNB6D/I	GWH18QD-K6DNA3D/I	
	Product Code	CB443N05802	CB435N09500	CB424N08100	
1	Decorative Strip	/	/	2019267602	1
2	Front Panel Assy	20000300103	20000300040T	2002278602	1
3	Display Board	30565260	30565278	30565262	1
4	Filter Sub-Assy	1112208906	1112208906	1112208906	2
5	Decorative Board (Left)	20192662	20192662	2019269302	1
6	Front Case	2002248401	2002248401	2002248401	1
7	Guide Louver	1051276501	1051276501	1051273402	1
8	Axile Bush	10542036	10542036	10542036	2
9	Air Louver 1	10512733	10512733	10512733	1
10	Helicoid tongue	26112512	26112512	26112512	1
11	Left Axile Bush	10512037	10512037	10512037	1
12	Rear Case assy	00000100001	00000100001	00000100001	1
13	Rubber Plug (Water Tray)	76712012	76712012	76712012	1
14	O-Gasket sub-assy of Bearing	76512051	76512051	76512051	1
15	Ring of Bearing	26152025	26152025	26152025	1
16	Evaporator Support	24212177	24212177	24212177	1
17	Evaporator Assy	011001000207	011001000207	011001000207	1
18	Cross Flow Fan	10352060	10352060	10352060	1
19	Fan Motor	1501214502	1501214502	1501214502	1
20	Motor Press Plate	26112511	26112511	26112511	1
21	Wall Mounting Frame	01362026	01362026	01362026	1
22	Connecting pipe clamp	2611218801	2611218801	2611218801	1
23	Crank	73012005	73012005	73012005	1
24	Stepping Motor	1521240212	1521240212	1521240212	1
25	Drainage hose	05230014	05230014	05230014	1
26	Electric Box Assy	100002062374	100002062363	100002066529	1
27	Lower Shield of Electric Box	01592139	01592139	01592139	1
28	Electric Box	2011221104	20112211	2011221104	1
29	Jumper	4202021921	4202021921	4202021912	1
30	Main Board	300002060236	300002060236	300002060236	1
31	Air Louver	10512736	10512736	10512736	1
32	Stepping Motor	1521210704	1521210704	1521210704	1
33	Air Louver 2	10512735	10512735	10512735	1
34	Swing Lever	10512731	10512731	10512731	1
35	Decorative Board (Right)	20192662	20192662	2019269302	1
36	Screw Cover	2425201726	2425201726	2425201726	3
37	Electric Box Cover2	20112210	20112210	20112210	1
38	Shield Cover of Electric Box	01592176	01592176	01592176	1
39	Electric Box Cover	20112209	20112209	20112209	1
40	Terminal Board	42011233	42011233	42011233	1
41	Power Cord	/	/	/	/
42	Connecting Cable	4002052317	4002052317	4002052317	0
43	Connecting Cable	/	/	/	/
44	Remote Controller	305001060023	305001060023	305001060023	1
45	Cold Plasma Generator	1114001602	1114001602	1114001602	1
46	Detecting Plate	30110144	30110144	30110144	1

Above data is subject to change without notice.

No.	Description	Part Code			Qty
		GWH18QD-K6DND2D/I			
	Product Code	CB461N05702	CB461N05701	CB461N05700	
1	Decorative Strip	/	/	/	/
2	Front Panel Assy	00000300003101	00000300003106	000003000031	1
3	Display Board	300001000034	30565308	30565278	1
4	Filter Sub-Assy	1112208906	1112208906	1112208906	2
5	Decorative Board (Left)	2019266201P	2019266201	20192662	1
6	Front Case	2002248402P	2002248402	2002248401	1
7	Guide Louver	1051276502	1051276502	1051276501	1
8	Axile Bush	10542036	10542036	10542036	2
9	Air Louver 1	10512733	10512733	10512733	1
10	Helicoid tongue	26112512	26112512	26112512	1
11	Left Axile Bush	10512037	10512037	10512037	1
12	Rear Case assy	00000100001	00000100001	00000100001	1
13	Rubber Plug (Water Tray)	76712012	76712012	76712012	1
14	O-Gasket sub-assy of Bearing	76512051	76512051	76512051	1
15	Ring of Bearing	26152025	26152025	26152025	1
16	Evaporator Support	24212177	24212177	24212177	1
17	Evaporator Assy	011001000207	011001000207	011001000207	1
18	Cross Flow Fan	10352060	10352060	10352060	1
19	Fan Motor	1501214502	1501214502	1501214502	1
20	Motor Press Plate	26112511	26112511	26112511	1
21	Wall Mounting Frame	01362026	01362026	01362026	1
22	Connecting pipe clamp	2611218801	2611218801	2611218801	1
23	Crank	73012005	73012005	73012005	1
24	Stepping Motor	1521240212	1521240212	1521240212	1
25	Drainage hose	05230014	05230014	05230014	1
26	Electric Box Assy	100002067947	100002067953	100002062363	1
27	Lower Shield of Electric Box	01592139	01592139	01592139	1
28	Electric Box	2011221104	2011221104	2011221104	1
29	Jumper	4202021921	4202021912	4202021921	1
30	Main Board	300002060236	300002060236	300002060236	1
31	Air Louver	10512736	10512736	10512736	1
32	Stepping Motor	1521210704	1521210704	1521210704	1
33	Air Louver 2	10512735	10512735	10512735	1
34	Swing Lever	10512731	10512731	10512731	1
35	Decorative Board (Right)	2019266201P	2019266201	20192662	1
36	Screw Cover	242520172P04	242520172P05	2425201726	3
37	Electric Box Cover2	2011221004P01	2011221004P	20112210	1
38	Shield Cover of Electric Box	01592176	01592176	01592176	1
39	Electric Box Cover	20112209	20112209	20112209	1
40	Terminal Board	42011233	42011233	42011233	1
41	Power Cord	/	/	/	/
42	Connecting Cable	4002052317	4002052317	4002052317	0
43	Connecting Cable	/	/	/	/
44	Remote Controller	305001060023	305001060023	305001060023	1
45	Cold Plasma Generator	1114001602	1114001602	1114001602	1
46	Detecting Plate	30110144	30110144	30110144	1

Above data is subject to change without notice.

No.	Description	Part Code			Qty
		GWH18QD-K6DNB2D/I	GWH18QD-K6DND6D/I	GWH18QD-K6DNB4D/I	
	Product Code	CB432N17901	CB460N06600	CB434N12501	
1	Decorative Strip	/	/	/	/
2	Front Panel Assy	20000300023S	200003000027	20000300028T	1
3	Display Board	30565260	300001000042	30565260	1
4	Filter Sub-Assy	1112208906	1112208906	1112208906	2
5	Decorative Board (Left)	20192662	20192662	20192662	1
6	Front Case	2002248401	2002248401	2002248401	1
7	Guide Louver	1051276501	1051276501	1051276501	1
8	Axile Bush	10542036	10542036	10542036	2
9	Air Louver 1	10512733	10512733	10512733	1
10	Helicoid tongue	26112512	26112512	26112512	1
11	Left Axile Bush	10512037	10512037	10512037	1
12	Rear Case assy	00000100001	00000100001	00000100001	1
13	Rubber Plug (Water Tray)	76712012	76712012	76712012	1
14	O-Gasket sub-assy of Bearing	76512051	76512051	76512051	1
15	Ring of Bearing	26152025	26152025	26152025	1
16	Evaporator Support	24212177	24212177	24212177	1
17	Evaporator Assy	011001000207	011001000207	011001000207	1
18	Cross Flow Fan	10352060	10352060	10352060	1
19	Fan Motor	1501214502	1501214502	1501214502	1
20	Motor Press Plate	26112511	26112511	26112511	1
21	Wall Mounting Frame	01362026	01362026	01362026	1
22	Connecting pipe clamp	2611218801	2611218801	2611218801	1
23	Crank	73012005	73012005	73012005	1
24	Stepping Motor	1521240212	1521240212	1521240212	1
25	Drainage hose	05230014	05230014	05230014	1
26	Electric Box Assy	100002062900	100002068642	100002069072	1
27	Lower Shield of Electric Box	01592139	01592139	01592139	1
28	Electric Box	2011221104	2011221104	2011221104	1
29	Jumper	4202021921	4202021921	4202021921	1
30	Main Board	300002060243	300002060236	300002060243	1
31	Air Louver	10512736	10512736	10512736	1
32	Stepping Motor	1521210704	1521210704	1521240212	1
33	Air Louver 2	10512735	10512735	10512735	1
34	Swing Lever	10512731	10512731	10512731	1
35	Decorative Board (Right)	20192662	20192662	/	1
36	Screw Cover	2425201726	2425201726	2425201726	3
37	Electric Box Cover2	20112210	20112210	20112210	1
38	Shield Cover of Electric Box	01592176	01592176	01592176	1
39	Electric Box Cover	20112209	20112209	20112209	1
40	Terminal Board	42011233	42011233	42011233	1
41	Power Cord	/	/	/	/
42	Connecting Cable	4002052317	4002052317	4002052317	0
43	Connecting Cable	/	/	/	/
44	Remote Controller	305001060023	305001060023	305001060023	1
45	Cold Plasma Generator	/	1114001602	/	1
46	Detecting Plate	30110144	30110144	30110144	1

Above data is subject to change without notice.

No.	Description	Part Code			Qty
		GWH18QD-K6DNA5X/I	GWH18QD-K6DNB8D/I	GWH18QD-K6DND2A/I	
	Product Code	CB425N15300	CB438N10301	CB461N06700	
1	Decorative Strip	20192703P	/	2019266201P01	1
2	Front Panel Assy	00000300035	20000300075T	00000300003106	1
3	Display Board	30565260	30565260	30565308	1
4	Filter Sub-Assy	1112208906	1112208906	1112208906	2
5	Decorative Board (Left)	2019261201	20192662	2019266201P01	1
6	Front Case	2002248401	2002248401	2002248402	1
7	Guide Louver	1051273402	1051276501	1051276502P01	1
8	Axile Bush	10542036	10542036	10542036	2
9	Air Louver 1	10512733	10512733	10512733	1
10	Helicoid tongue	26112512	26112512	26112512	1
11	Left Axile Bush	10512037	10512037	10512037	1
12	Rear Case assy	00000100001	00000100001	00000100001	1
13	Rubber Plug (Water Tray)	76712012	76712012	76712012	1
14	O-Gasket sub-assy of Bearing	76512051	76512051	76512051	1
15	Ring of Bearing	26152025	26152025	26152025	1
16	Evaporator Support	24212177	24212177	24212177	1
17	Evaporator Assy	011001000207	011001000207	011001000146	1
18	Cross Flow Fan	10352060	10352060	10352060	1
19	Fan Motor	1501214502	1501214502	15012136	1
20	Motor Press Plate	26112511	26112511	26112511	1
21	Wall Mounting Frame	01362026	01362026	01362026	1
22	Connecting pipe clamp	2611218801	2611218801	2611218801	1
23	Crank	73012005	73012005	73012005	1
24	Stepping Motor	1521240212	1521240212	1521240212	1
25	Drainage hose	05230014	05230014	05230014	1
26	Electric Box Assy	100002062364	100002062900	100002071242	1
27	Lower Shield of Electric Box	01592139	01592139	01592139	1
28	Electric Box	2011221104	2011221104	2011221104	1
29	Jumper	4202021912	4202021921	4202021924	1
30	Main Board	300002060236	300002060243	300002060785	1
31	Air Louver	10512736	10512736	10512736	1
32	Stepping Motor	1521210704	1521210704	1521210704	1
33	Air Louver 2	10512735	10512735	10512735	1
34	Swing Lever	10512731	10512731	10512731	1
35	Decorative Board (Right)	2019261101	20192662	2019266201P01	1
36	Screw Cover	2425201726	2425201726	242520172P05	3
37	Electric Box Cover2	20112210	20112210	2011221004P	1
38	Shield Cover of Electric Box	01592176	01592176	01592176	1
39	Electric Box Cover	20112209	20112209	20112209	1
40	Terminal Board	42011233	42011233	42011233	1
41	Power Cord	/	/	/	/
42	Connecting Cable	4002052317	4002052317	4002052317	0
43	Connecting Cable	/	/	/	/
44	Remote Controller	305001060023	305001060023	305001000081	1
45	Cold Plasma Generator	1114001602	/	/	1
46	Detecting Plate	30110144	30110144	30110144	1

Above data is subject to change without notice.

GWH18QD-K6DNE4D/I(CB470N03001) GWH18QD-K6DNA5D/I(CB425N12402) GWH18QD-K6DNC4D/I(CB444N12300)

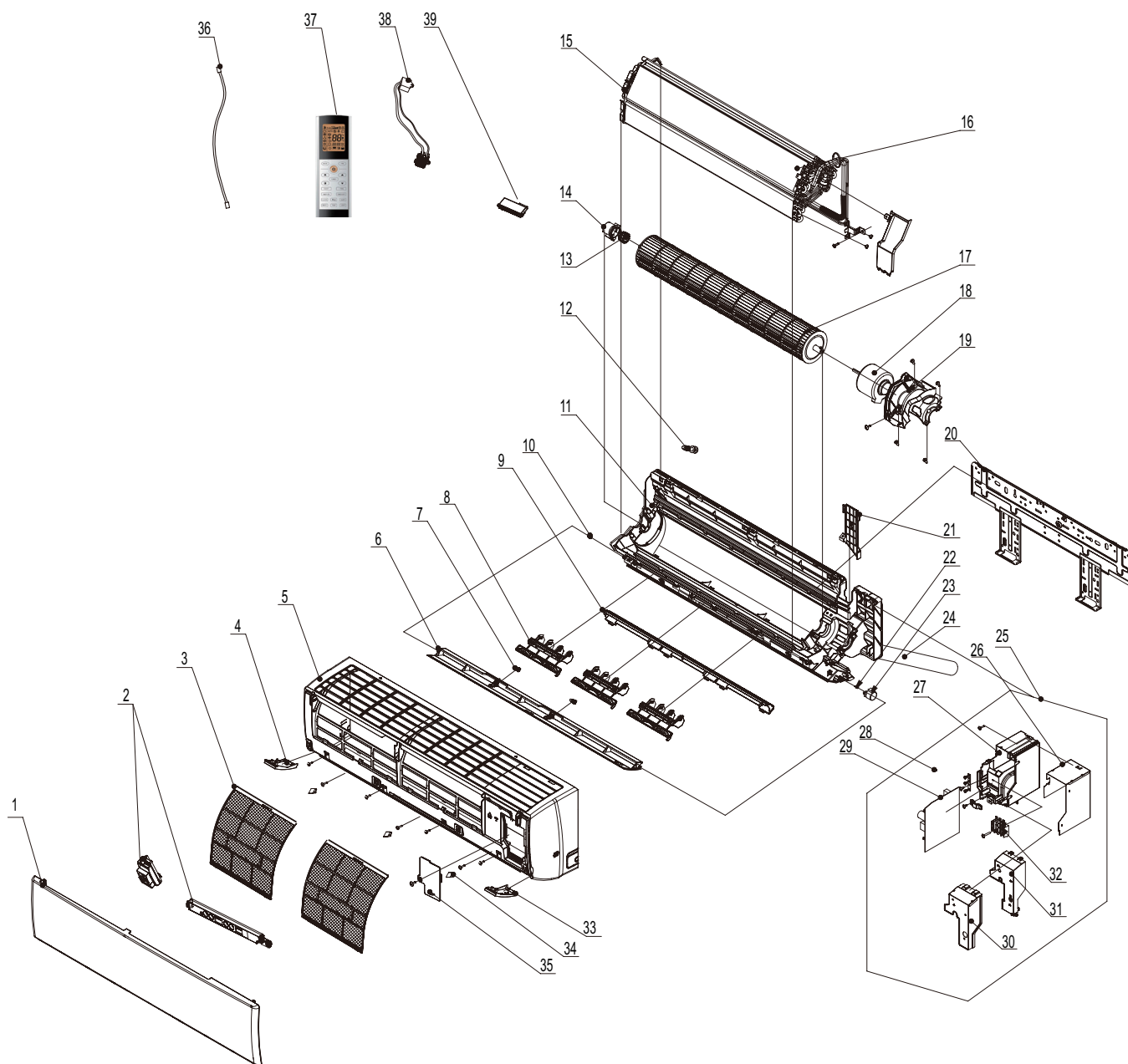

The component picture is only for reference; please refer to the actual product.

No.	Description	Part Code			Qty
		GWH18QD-K6DNE4D/I	GWH18QD-K6DNA5D/I	GWH18QD-K6DNC4D/I	
	Product Code	CB470N03001	CB425N12402	CB444N12300	
1	Front Panel	200003000064T	2002266901S01	20000300106S	1
2	Display Board	300001000081	30565260	30565260	1
3	Filter Sub-Assy	1112208906	1112208906	1112208906	2
4	Decorative Board	20192662	2019261204	20192662	1
5	Front Case	2002248401	2002248403	2002248401	1
6	Guide Louver	1051276501	1051273402	1051276501	1
7	Axile Bush	10542036	10542036	10542036	2
8	Air Louver(Manual)	10512732	10512732	10512732	3
9	Helicoid tongue	26112512	26112512	26112512	1
10	Left Axile Bush	10512037	10512037	10512037	1
11	Rear Case assy	22202571	22202571	22202571	1
12	Rubber Plug (Water Tray)	76712012	76712012	76712012	1
13	O-Gasket sub-assy of Bearing	76512051	76512051	76512051	1
14	Ring of Bearing	26152025	26152025	26152025	1
15	Evaporator Support	24212177	24212177	24212177	1
16	Evaporator Assy	011001000207	011001000207	011001000207	1
17	Cross Flow Fan	10352060	10352060	10352060	1
18	Fan Motor	1501214502	1501214502	1501214502	1
19	Motor Press Plate	26112511	26112511	26112511	1
20	Wall Mounting Frame	01362026	01362026	01362026	1
21	Connecting pipe clamp	2611218801	2611218801	2611218801	1
22	Crank	73012005	73012005	73012005	1
23	Stepping Motor	1521240212	1521240212	1521240212	1
24	Drainage hose	05230014	05230014	05230014	1
25	Electric Box Assy	100002062909	100002065980	100002066276	1
26	Lower Shield of Electric Box	01592139	01592139	01592139	1
27	Electric Box	20112211	20112211	20112211	1
28	Jumper	4202021921	4202021912	4202021921	1
29	Main Board	300002060469	300002060469	300002060916	1
30	Shield Cover of Electric Box	01592176	01592176	01592176	1
31	Electric Box Cover	20112209	20112209	20112209	1
32	Terminal Board	42011233	42011233	42011233	1
33	Decorative Board	20192662	2019261104	20192662	1
34	Screw Cover	2425201726	2425201726	2425201726	3
35	Electric Box Cover2	20112210	20112210	20112210	1
36	Connecting Cable	4002052317	4002052317	4002052317	0
37	Remote Controller	305001060023	305001060023	305001060023	1
38	Cold Plasma Generator	/	/	1114001602	1
39	Detecting plate(WIFI)	30110144	30110144	30110144	1

Above data is subject to change without notice.

24K For some models

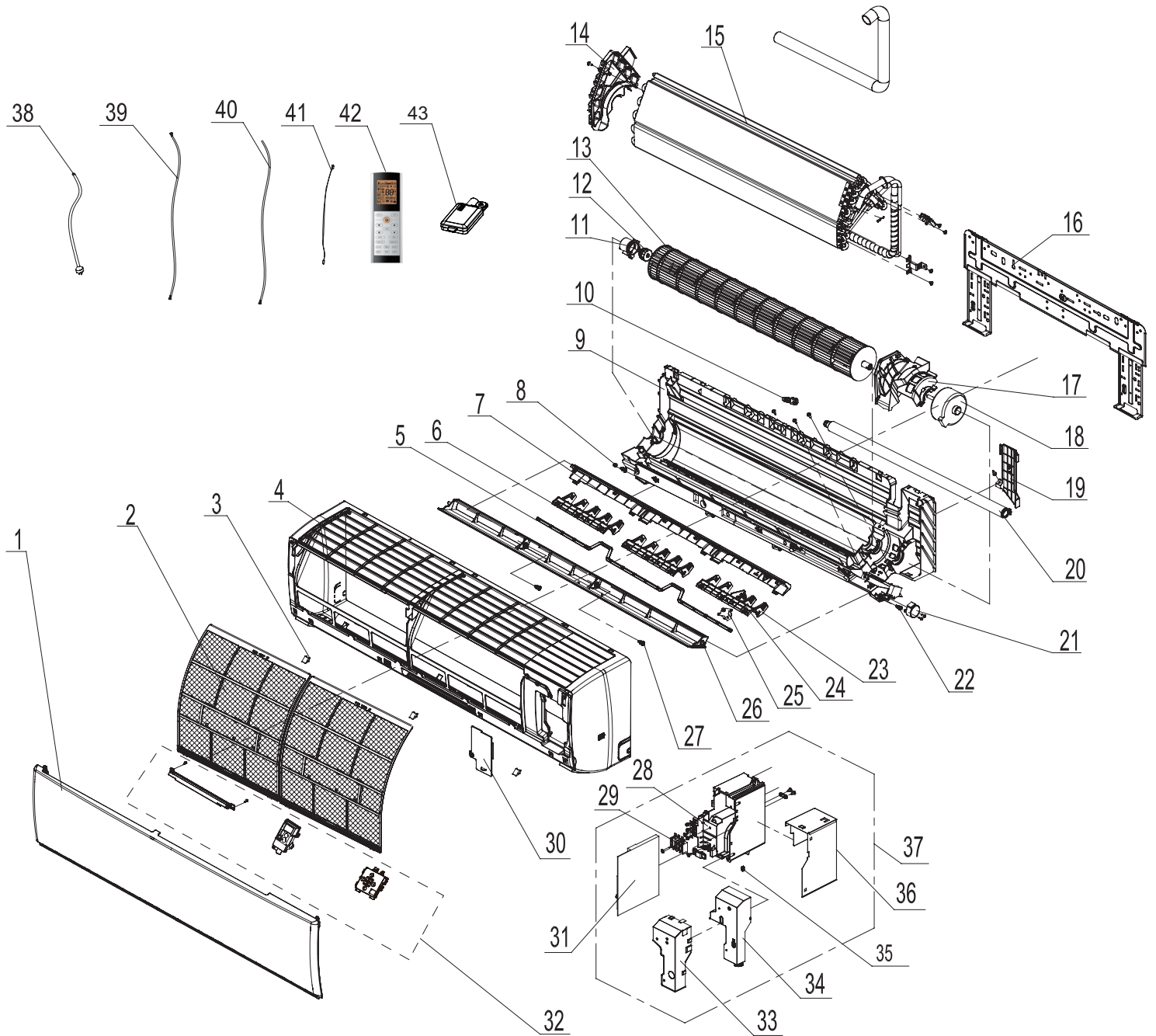

The component picture is only for reference; please refer to the actual product.

No.	Description	Part Code			Qty
		GWH24QE-K6DNA1E/I	GWH24QE-K6DNC2E/I	GWH24QE-K6DNB6E/I	
	Product Code	CB419N15700	CB439N13000	CB435N09300	
1	Front Panel Assy	20022491	20000300071S	20000300048T	1
2	Filter Sub-Assy	1101200703	1101200703	1101200703	2
3	Screw Cover	24252453	2425245301	2425245301	3
4	Front Case Assy	20022487	00000200043	00000200043	1
5	Swing Lever	10512743	10512743	10512743	1
6	Air Louver	10512744	10512744	10512744	1
7	Helicoid Tongue sub-assy	26112384	26112384	26112384	1
8	Left Axile Bush	10512037	10512037	10512037	1
9	Rear Case assy	22202736	22202736	22202736	1
10	Rubber Plug (Water Tray)	76712012	76712012	76712012	1
11	Ring of Bearing	26152025	26152025	26152025	1
12	O-Gasket sub-assy of Bearing	76512051	76512051	76512051	1
13	Cross Flow Fan	10352057	10352057	10352057	1
14	Evaporator Support	24212178	24212178	24212178	1
15	Evaporator Assy	01100100007303	01100100007303	01100100007303	1
16	Wall Mounting Frame	01252229	01252229	01252229	1
17	Motor Press Plate	26112515	26112515	26112515	1
18	Fan Motor	15012145	15012145	15012145	1
19	Connecting pipe clamp	26112514	26112514	26112514	1
20	Drainage Hose	0523001405	0523001405	0523001405	1
21	Stepping Motor	1521240212	1521240212	1521240212	1
22	Crank	73012005	73012005	73012005	1
23	Air Louver 1	10512741	10512741	10512741	2
24	Air Louver 1	10512742	10512742	10512742	1
25	Stepping Motor	1521210704	1521210704	1521210704	1
26	Guide Louver	10512738	1051232001	1051232001	1
27	Axile Bush	10542036	10542036	10542036	2
28	Electric Box	2011221102	2011221102	2011221102	1
29	Terminal Board	42011233	42011233	42011233	1
30	Electric Box Cover 2	20112210	20112210	20112210	1
31	Main Board	300002060239	300002060239	300002060239	1
32	Display Board	30565233	30565278	30565278	1
33	Shield Cover of Electric Box	01592139	01592176	01592176	1
34	Electric Box Cover	20112209	20112209	20112209	1
35	Jumper	4202021916	4202021925	4202021925	1
36	Lower Shield of Electric Box	01592139	01592139	01592139	1
37	Electric Box Assy	100002061455	100002062357	100002062357	1
38	Power Cord	/	/	/	/
39	Connecting Cable	4002052317	4002052317	4002052317	0
40	Connecting Cable	/	/	/	/
41	Temperature Sensor	3900031302	3900031302	3900031302	1
42	Remote Controller	305001060023	305001060023	305001060023	1
43	Detecting Plate	30110144	30110144	30110144	1

Above data is subject to change without notice.

No.	Description	Part Code			Qty
		GWH24QE-K6DNB2E/I	GWH24QE-K6DNA5E/I	GWH24QE-K6DNB4E/I	
	Product Code	CB432N17700	CB425N12200	CB434N12400	
1	Front Panel Assy	20000300016S	00000300021	20000300029T	1
2	Filter Sub-Assy	1101200703	1101200703	1101200703	2
3	Screw Cover	2425245301	2425245301	2425245301	3
4	Front Case Assy	00000200043	00000200013	00000200043	1
5	Swing Lever	10512743	10512743	10512743	1
6	Air Louver	10512744	10512744	10512744	1
7	Helicoid Tongue sub-assy	26112384	26112384	26112384	1
8	Left Axile Bush	10512037	10512037	10512037	1
9	Rear Case assy	22202736	22202736	22202736	1
10	Rubber Plug (Water Tray)	76712012	76712012	76712012	1
11	Ring of Bearing	26152025	26152025	26152025	1
12	O-Gasket sub-assy of Bearing	76512051	76512051	76512051	1
13	Cross Flow Fan	10352057	10352057	10352057	1
14	Evaporator Support	24212178	24212178	24212178	1
15	Evaporator Assy	01100100007303	01100100007303	01100100007303	1
16	Wall Mounting Frame	01252229	01252229	01252229	1
17	Motor Press Plate	26112515	26112515	26112515	1
18	Fan Motor	15012145	15012145	15012145	1
19	Connecting pipe clamp	26112514	26112514	26112514	1
20	Drainage Hose	0523001405	0523001405	0523001405	1
21	Stepping Motor	1521240212	1521240212	1521240212	1
22	Crank	73012005	73012005	73012005	1
23	Air Louver 1	10512741	10512741	10512741	2
24	Air Louver 1	10512742	10512742	10512742	1
25	Stepping Motor	1521210704	1521210704	1521210704	1
26	Guide Louver	1051232001	1051273802	1051232001	1
27	Axile Bush	10542036	10542036	10542036	2
28	Electric Box	2011221102	2011221102	2011221102	1
29	Terminal Board	42011233	42011233	42011233	1
30	Electric Box Cover 2	20112210	20112210	20112210	1
31	Main Board	300002060239	300002060239	300002060239	1
32	Display Board	30565260	30565260	30565260	1
33	Shield Cover of Electric Box	01592176	01592176	01592176	1
34	Electric Box Cover	20112209	20112209	20112209	1
35	Jumper	4202021925	4202021916	4202021925	1
36	Lower Shield of Electric Box	01592139	01592139	01592139	1
37	Electric Box Assy	100002062375	100002062358	100002062375	1
38	Power Cord	/	/	/	/
39	Connecting Cable	4002052317	4002052317	4002052317	0
40	Connecting Cable	/	/	/	/
41	Temperature Sensor	3900031302	3900031302	3900031302	1
42	Remote Controller	305001060023	305001060023	305001060023	1
43	Detecting Plate	30110144	30110144	30110144	1

Above data is subject to change without notice.

No.	Description	Part Code			Qty
		GWH24QE-K6DNC4E/I	GWH24QE-K6DNE4E/I	GWH24QE-K6DNB8E/I	
	Product Code	CB444N09800	CB470N02800	CB438N10400	
1	Front Panel Assy	20000300099S	200003000062T	20000300076T	1
2	Filter Sub-Assy	1101200703	1101200703	1101200703	2
3	Screw Cover	2425245301	2425245301	2425245301	3
4	Front Case Assy	00000200043	00000200043	00000200043	1
5	Swing Lever	10512743	10512743	10512743	1
6	Air Louver	10512744	10512744	10512744	1
7	Helicoid Tongue sub-assy	26112384	26112384	26112384	1
8	Left Axile Bush	10512037	10512037	10512037	1
9	Rear Case assy	22202736	22202736	22202736	1
10	Rubber Plug (Water Tray)	76712012	76712012	76712012	1
11	Ring of Bearing	26152025	26152025	26152025	1
12	O-Gasket sub-assy of Bearing	76512051	76512051	76512051	1
13	Cross Flow Fan	10352057	10352057	10352057	1
14	Evaporator Support	24212178	24212178	24212178	1
15	Evaporator Assy	01100100007303	01100100007303	01100100007303	1
16	Wall Mounting Frame	01252229	01252229	01252229	1
17	Motor Press Plate	26112515	26112515	26112515	1
18	Fan Motor	15012145	15012145	15012145	1
19	Connecting pipe clamp	26112514	26112514	26112514	1
20	Drainage Hose	0523001405	0523001405	0523001405	1
21	Stepping Motor	1521240212	1521240212	1521240212	1
22	Crank	73012005	73012005	73012005	1
23	Air Louver 1	10512741	10512741	10512741	2
24	Air Louver 1	10512742	10512742	10512742	1
25	Stepping Motor	1521210704	1521210704	1521240212	1
26	Guide Louver	1051232001	1051232001	1051232001	1
27	Axile Bush	10542036	10542036	10542036	2
28	Electric Box	2011221102	2011221102	2011221102	1
29	Terminal Board	42011233	42011233	42011233	1
30	Electric Box Cover 2	20112210	20112210	20112210	1
31	Main Board	300002060239	300002060239	300002060239	1
32	Display Board	30565260	300001000081	30565260	1
33	Shield Cover of Electric Box	01592176	01592176	01592139	1
34	Electric Box Cover	20112209	20112209	20112209	1
35	Jumper	4202021925	4202021925	4202021925	1
36	Lower Shield of Electric Box	01592139	01592139	01592139	1
37	Electric Box Assy	100002062375	100002062378	100002062375	1
38	Power Cord	/	/	/	/
39	Connecting Cable	4002052317	4002052317	4002052317	0
40	Connecting Cable	/	/	/	/
41	Temperature Sensor	3900031302	3900031302	3900031302	1
42	Remote Controller	305001060023	305001060023	305001060023	1
43	Detecting Plate	30110144	30110144	30110144	1

Above data is subject to change without notice.



No.	Description	Part Code			Qty
		GWH24QE-K6DNC6E/I	GWH24QE-K6DNC6E/I	GWH24QE-K6DNB6E/I	
	Product Code	CB443N05900	CB443N05903	CB435N09300	
1	Front Panel Assy	20000300104T	20000300104T	20000300048T	1
2	Filter Sub-Assy	1101200703	1101200703	1101200703	2
3	Screw Cover	2425245301	2425245301	2425245301	3
4	Front Case Assy	00000200043	00000200043	00000200043	1
5	Swing Lever	10512743	10512743	10512743	1
6	Air Louver	10512744	10512744	10512744	3
7	Helicoid Tongue sub-assy	26112384	26112384	26112384	1
8	Left Axile Bush	10512037	10512037	10512037	1
9	Rear Case assy	22202736	22202736	22202736	1
10	Rubber Plug (Water Tray)	76712012	76712012	76712012	1
11	Ring of Bearing	26152025	26152025	26152025	1
12	O-Gasket sub-assy of Bearing	76512051	76512051	76512051	1
13	Cross Flow Fan	10352057	10352057	10352057	1
14	Evaporator Support	24212178	24212178	24212178	1
15	Evaporator Assy	01100100007303	01100100007303	01100100007303	1
16	Wall Mounting Frame	01252229	01252229	01252229	1
17	Motor Press Plate	26112515	26112515	26112515	1
18	Fan Motor	15012145	15012145	15012145	1
19	Connecting pipe clamp	26112514	26112514	26112514	1
20	Drainage Hose	0523001405	0523001405	0523001405	1
21	Stepping Motor	1521240212	1521240212	1521240212	1
22	Crank	73012005	73012005	73012005	1
23	Air Louver 1	10512741	10512741	10512741	2
24	Air Louver	10512742	10512742	10512742	1
25	Stepping Motor	1521210704	1521210704	1521210704	1
26	Guide Louver	1051232001	1051232001	1051232001	1
27	Axile Bush	10542036	10542036	10542036	2
28	Electric Box	2011221102	2011221102	2011221102	1
29	Terminal Board	42011233	42011233	42011233	1
30	Electric Box Cover 2	20112210	20112210	20112210	1
31	Main Board	300002060242	300002060239	300002060239	1
32	Display Board	30565260	30565260	30565278	1
33	Shield Cover of Electric Box	01592139	01592139	01592139	1
34	Electric Box Cover	20112209	20112209	20112209	1
35	Jumper	4202021925	4202021925	4202021925	1
36	Lower Shield of Electric Box	01592139	01592139	01592139	1
37	Electric Box Assy	100002062930	100002062375	100002062357	1
38	Power Cord	/	/	/	/
39	Connecting Cable	4002052317	4002052317	4002052317	0
40	Connecting Cable	/	/	/	/
41	Temperature Sensor	3900031302	3900031302	3900031302	1
42	Remote Controller	305001060023	305001060023	305001060023	1
43	Detecting Plate	30110144	30110144	30110144	1

Above data is subject to change without notice.

No.	Description	Part Code			Qty
		GWH24QE-K6DND2E/I			
		Product Code	CB461N05602	CB461N05601	
1	Front Panel Assy	00000300233	0000030023502	00000300234	1
2	Filter Sub-Assy	1101200703	1101200703	1101200703	2
3	Screw Cover	2425245302P01	2425245302P	2425245301	3
4	Front Case Assy	00000200174	0000020017301	00000200043	1
5	Swing Lever	10512743	10512743	10512743	1
6	Air Louver	10512744	10512744	10512744	3
7	Helicoid Tongue sub-assy	26112384	26112384	26112384	1
8	Left Axile Bush	10512037	10512037	10512037	1
9	Rear Case assy	22202736	22202736	22202736	1
10	Rubber Plug (Water Tray)	76712012	76712012	76712012	1
11	Ring of Bearing	26152025	26152025	26152025	1
12	O-Gasket sub-assy of Bearing	76512051	76512051	76512051	1
13	Cross Flow Fan	10352057	10352057	10352057	1
14	Evaporator Support	24212178	24212178	24212178	1
15	Evaporator Assy	01100100007303	01100100007303	01100100007303	1
16	Wall Mounting Frame	01252229	01252229	01252229	1
17	Motor Press Plate	26112515	26112515	26112515	1
18	Fan Motor	15012145	15012145	15012145	1
19	Connecting pipe clamp	26112514	26112514	26112514	1
20	Drainage Hose	0523001405	0523001405	0523001405	1
21	Stepping Motor	1521240212	1521240212	1521240212	1
22	Crank	73012005	73012005	73012005	1
23	Air Louver 1	10512741	10512741	10512741	2
24	Air Louver	10512742	10512742	10512742	1
25	Stepping Motor	1521210704	1521210704	1521210704	1
26	Guide Louver	1051232002P01	1051232002P	1051232001	1
27	Axile Bush	10542036	10542036	10542036	2
28	Electric Box	2011221105	2011221105	2011221105	1
29	Terminal Board	42011233	42011233	42011233	1
30	Electric Box Cover 2	2011221004P01	2011221004P	20112210	1
31	Main Board	300002060239	300002060239	300002060239	1
32	Display Board	300001000034	30565308	30565278	1
33	Shield Cover of Electric Box	01592139	01592139	01592139	1
34	Electric Box Cover	20112209	20112209	20112209	1
35	Jumper	4202021925	4202021925	4202021925	1
36	Lower Shield of Electric Box	01592139	01592139	01592139	1
37	Electric Box Assy	100002067950	100002067954	100002062357	1
38	Power Cord	/	/	/	/
39	Connecting Cable	4002052317	4002052317	4002052317	0
40	Connecting Cable	/	/	/	/
41	Temperature Sensor	3900031302	3900031302	3900031302	1
42	Remote Controller	305001060023	305001060023	305001060023	1
43	Detecting Plate	30110144	30110144	30110144	1

Above data is subject to change without notice.



No.	Description	Part Code			Qty
		GWH24QE-K6DNB2E/I	GWH24QE-K6DND6E/I	GWH24QE-K6DNB8E/I	
	Product Code	CB432N17701	CB460N06500	CB438N10401	
1	Front Panel Assy	20000300016S	200003000023S	20000300076T	1
2	Filter Sub-Assy	1101200703	1101200703	1101200703	2
3	Screw Cover	2425245301	2425245301	2425245301	3
4	Front Case Assy	00000200043	00000200043	00000200043	1
5	Swing Lever	10512743	10512743	10512743	1
6	Air Louver	10512744	10512744	10512744	3
7	Helicoid Tongue sub-assy	26112384	26112384	26112384	1
8	Left Axile Bush	10512037	10512037	10512037	1
9	Rear Case assy	22202736	22202736	22202736	1
10	Rubber Plug (Water Tray)	76712012	76712012	76712012	1
11	Ring of Bearing	26152025	26152025	26152025	1
12	O-Gasket sub-assy of Bearing	76512051	76512051	76512051	1
13	Cross Flow Fan	10352057	10352057	10352057	1
14	Evaporator Support	24212178	24212178	24212178	1
15	Evaporator Assy	01100100007303	01100100007303	01100100007303	1
16	Wall Mounting Frame	01252229	01252229	01252229	1
17	Motor Press Plate	26112515	26112515	26112515	1
18	Fan Motor	15012145	15012145	15012145	1
19	Connecting pipe clamp	26112514	26112514	26112514	1
20	Drainage Hose	0523001405	0523001405	0523001405	1
21	Stepping Motor	1521240212	1521240212	1521240212	1
22	Crank	73012005	73012005	73012005	1
23	Air Louver 1	10512741	10512741	10512741	2
24	Air Louver	10512744	10512741	10512744	1
25	Stepping Motor	1521210704	1521210704	1521210704	1
26	Guide Louver	1051232001	1051232001	1051232001	1
27	Axile Bush	10542036	10542036	10542036	2
28	Electric Box	2011221105	2011221105	2011221105	1
29	Terminal Board	42011233	42011233	42011233	1
30	Electric Box Cover 2	20112210	20112210	20112210	1
31	Main Board	300002060242	300002060239	300002060242	1
32	Display Board	30565260	300001000042	30565260	1
33	Shield Cover of Electric Box	01592139	01592176	01592139	1
34	Electric Box Cover	20112209	20112209	20112209	1
35	Jumper	4202021925	4202021925	4202021925	1
36	Lower Shield of Electric Box	01592139	01592139	01592139	1
37	Electric Box Assy	100002062930	100002068636	100002062930	1
38	Power Cord	/	/	/	/
39	Connecting Cable	4002052317	4002052317	4002052317	0
40	Connecting Cable	/	/	/	/
41	Temperature Sensor	3900031302	3900031302	3900031302	1
42	Remote Controller	305001060023	305001060023	305001060023	1
43	Detecting Plate	30110144	30110144	30110144	1

Above data is subject to change without notice.

No.	Description	Part Code			Qty
		GWH24QE-K6DNB4E/I	GWH24QE-K6DNA5X/I	GWH24QE-K6DND2I/I	
	Product Code	CB434N12403	CB425N15400	CB461N06800	
1	Front Panel Assy	20000300029T	00000300021	0000030023502	1
2	Filter Sub-Assy	1101200703	1101200703	1101200703	2
3	Screw Cover	2425245301	2425245301	2425245302P	3
4	Front Case Assy	00000200043	00000200013	0000020017301	1
5	Swing Lever	10512743	10512743	10512743	1
6	Air Louver	10512744	10512744	10512744	3
7	Helicoid Tongue sub-assy	26112384	26112384	26112384	1
8	Left Axile Bush	10512037	10512037	10512037	1
9	Rear Case assy	22202736	22202736	22202736	1
10	Rubber Plug (Water Tray)	76712012	76712012	76712012	1
11	Ring of Bearing	26152025	26152025	26152025	1
12	O-Gasket sub-assy of Bearing	76512051	76512051	76512051	1
13	Cross Flow Fan	10352057	10352057	10352057	1
14	Evaporator Support	24212178	24212178	24212178	1
15	Evaporator Assy	01100100007303	01100100007303	011001000095	1
16	Wall Mounting Frame	01252229	01252229	01252229	1
17	Motor Press Plate	26112515	26112515	26112515	1
18	Fan Motor	15012145	15012145	15012136	1
19	Connecting pipe clamp	26112514	26112514	26112514	1
20	Drainage Hose	0523001405	0523001405	0523001405	1
21	Stepping Motor	1521240212	1521240212	1521240212	1
22	Crank	73012005	73012005	73012005	1
23	Air Louver 1	10512741	10512741	10512741	2
24	Air Louver	10512742	10512742	10512742	1
25	Stepping Motor	1521210704	1521210704	1521210704	1
26	Guide Louver	1051232001	1051273802	1051232002P	1
27	Axile Bush	10542036	10542036	10542036	2
28	Electric Box	2011221105	2011221105	2011221104	1
29	Terminal Board	42011233	42011233	42011233	1
30	Electric Box Cover 2	20112210	20112210	2011221004P	1
31	Main Board	300002060242	300002060239	300002060785	1
32	Display Board	30565260	30565260	30565308	1
33	Shield Cover of Electric Box	01592139	01592176	01592176	1
34	Electric Box Cover	20112209	20112209	2011220901	1
35	Jumper	4202021925	4202021916	4202021921	1
36	Lower Shield of Electric Box	01592139	01592139	01592139	1
37	Electric Box Assy	100002069071	100002062358	100002062958	1
38	Power Cord	/	/	/	/
39	Connecting Cable	4002052317	4002052317	4002052317	0
40	Connecting Cable	/	/	/	/
41	Temperature Sensor	3900031302	3900031302	3900031302	1
42	Remote Controller	305001060023	305001060023	305001000081	1
43	Detecting Plate	30110144	30110144	30110144	1

Above data is subject to change without notice.

GWH24QE-K6DNE4E/I(CB470N02801) GWH24QE-K6DNB4E/I(CB434N12402) GWH24QE-K6DNA5E/I(CB425N12203)
 GWH24QE-K6DNC6E/I(CB443N05902) GWH24QE-K6DNA5E/I(CB425N12202) GWH24QE-K6DNC4E/I(CB444N09801)
 GWH24QE-K6DNC2E/I(CB439N13001)

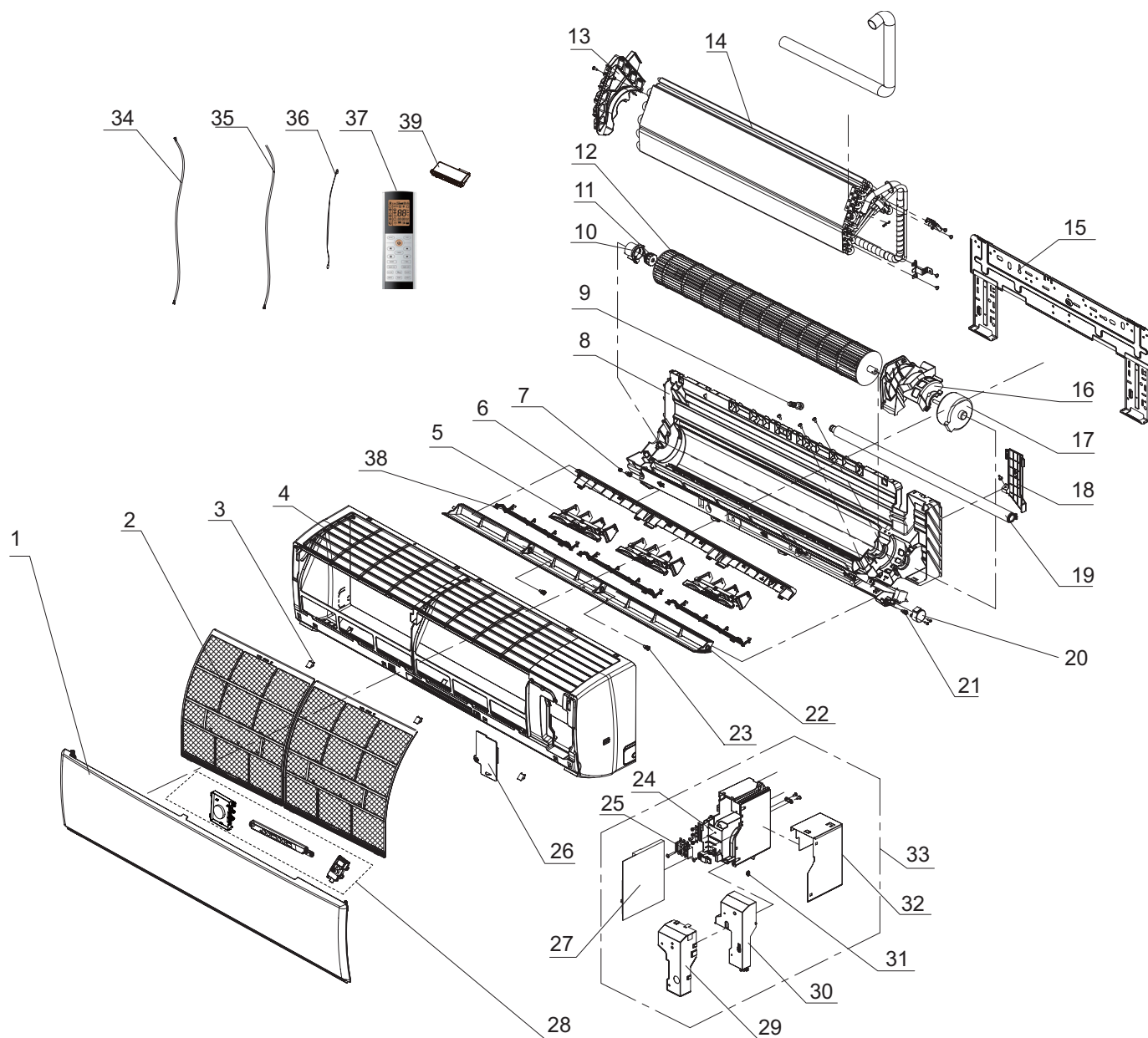

The component picture is only for reference; please refer to the actual product.

No.	Description	Part Code			Qty
		GWH24QE-K6DNE4E/I	GWH24QE-K6DNB4E/I	GWH24QE-K6DNA5E/I	
	Product Code	CB470N02801	CB434N12402	CB425N12203	
1	Front Panel	200003000062T	20000300029T	2002267401S01	1
2	Filter Sub-Assy	1101200703	1101200703	1101200703	2
3	Screw Cover	2425245301	2425245301	2425245301	3
4	Front Case Assy	00000200043	00000200043	00000200013	1
5	Air Louver(Manual)	10512737	10512737	10512737	3
6	Helicoid Tongue	26112513	26112513	26112513	1
7	Left Axile Bush	10512037	10512037	10512037	1
8	Rear Case assy	22202570	22202570	22202570	1
9	Rubber Plug (Water Tray)	76712012	76712012	76712012	1
10	Ring of Bearing	26152025	26152025	26152025	1
11	O-Gasket of Cross Fan Bearing	76512203	76512203	76512203	1
12	Cross Flow Fan	10352057	10352057	10352057	1
13	Evaporator Support	24212178	24212178	24212178	1
14	Evaporator Assy	01100100007303	01100100007303	01100100007303	1
15	Wall Mounting Frame	01252229	01252229	01252229	1
16	Motor Press Plate	26112515	26112515	26112515	1
17	Fan Motor	15012145	15012145	15012145	1
18	Connecting pipe clamp	26112514	26112514	26112514	1
19	Drainage Hose	0523001405	0523001405	0523001405	1
20	Stepping Motor	1521240212	1521240212	1521240212	1
21	Crank	73012005	73012005	73012005	1
22	Guide Louver	1051232001	1051232001	1051273802	1
23	Axile Bush	10542036	10542036	10542036	2
24	Electric Box	2011221102	2011221102	20112211	1
25	Terminal Board	42011233	42011233	42011233	1
26	Electric Box Cover2	20112210	20112210	20112210	1
27	Main Board	300002060468	300002060468	300002060468	1
28	Display Board	300001000081	30565260	30565260	1
29	Shield Cover of Electric Box	01592176	01592176	01592176	1
30	Electric Box Cover	20112209	20112209	20112209	1
31	Jumper cap	4202021925	4202021925	4202021916	1
32	Lower Shield of Electric Box	01592139	01592139	01592139	1
33	Electric Box Assy	100002062915	100002062957	100002065979	1
36	Temperature Sensor	3900031302	3900031302	3900031302	1
37	Remote Controller	305001060023	305001060023	305001060023	1
38	Rear Grill Sub-assy	/	/	/	/
37	Shield Cover of Electric Box Cover	01592176	01592176	01592176	1
38	Electric Box Cover	20112209	20112209	20112209	1
39	Detecting plate(WIFI)	30110144	30110144	30110144	1

Above data is subject to change without notice.

No.	Description	Part Code			Qty
		GWH24QE-K6DNC6E/I	GWH24QE-K6DNA5E/I	GWH24QE-K6DNC4E/I	
	Product Code	CB443N05902	CB425N12202	CB444N09801	
1	Front Panel	20000300104T	2002267401S01	20000300099S	1
2	Filter Sub-Assy	1101200703	1101200703	1101200703	2
3	Screw Cover	2425245301	2425245301	2425245301	3
4	Front Case Assy	00000200043	00000200013	00000200043	1
5	Air Louver(Manual)	10512737	10512737	10512737	3
6	Helicoid Tongue	26112513	26112513	26112513	1
7	Left Axile Bush	10512037	10512037	10512037	1
8	Rear Case assy	22202570	22202570	22202570	1
9	Rubber Plug (Water Tray)	76712012	76712012	76712012	1
10	Ring of Bearing	26152025	26152025	26152025	1
11	O-Gasket of Cross Fan Bearing	76512203	76512203	76512203	1
12	Cross Flow Fan	10352057	10352057	10352057	1
13	Evaporator Support	24212178	24212178	24212178	1
14	Evaporator Assy	01100100007303	01100100007303	01100100007303	1
15	Wall Mounting Frame	01252229	01252229	01252229	1
16	Motor Press Plate	26112515	26112515	26112515	1
17	Fan Motor	15012145	15012145	15012145	1
18	Connecting pipe clamp	26112514	26112514	26112514	1
19	Drainage Hose	0523001405	0523001405	0523001405	1
20	Stepping Motor	1521240212	1521240212	1521240212	1
21	Crank	73012005	73012005	73012005	1
22	Guide Louver	1051232001	1051273802	1051232001	1
23	Axile Bush	10542036	10542036	10542036	2
24	Electric Box	2011221102	2011221102	2011221102	1
25	Terminal Board	42011233	42011233	42011233	1
26	Electric Box Cover2	20112210	20112210	20112210	1
27	Main Board	300002060468	300002060468	300002060917	1
28	Display Board	30565260	30565260	30565260	1
29	Shield Cover of Electric Box	01592176	01592176	01592176	1
30	Electric Box Cover	20112209	20112209	20112209	1
31	Jumper cap	4202021925	4202021916	4202021925	1
32	Lower Shield of Electric Box	01592139	01592139	01592139	1
33	Electric Box Assy	100002062957	100002062961	100002066205	1
36	Temperature Sensor	3900031302	3900031302	3900031302	1
37	Remote Controller	305001060023	305001060023	305001060023	1
38	Rear Grill Sub-assy	/	/	/	/
37	Shield Cover of Electric Box Cover	01592176	01592176	01592176	1
38	Electric Box Cover	20112209	20112209	20112209	1
39	Detecting plate(WIFI)	30110144	30110144	30110144	1

Above data is subject to change without notice.

No.	Description	Part Code	
		GWH24QE-K6DNC2E/I	
		Product Code	Qty
		CB439N13001	
1	Front Panel	20000300071S	1
2	Filter Sub-Assy	1101200703	2
3	Screw Cover	2425245301	3
4	Front Case Assy	00000200043	1
5	Air Louver(Manual)	10512737	3
6	Helicoid Tongue	26112513	1
7	Left Axile Bush	10512037	1
8	Rear Case assy	22202570	1
9	Rubber Plug (Water Tray)	76712012	1
10	Ring of Bearing	26152025	1
11	O-Gasket of Cross Fan Bearing	76512203	1
12	Cross Flow Fan	10352057	1
13	Evaporator Support	24212178	1
14	Evaporator Assy	01100100007303	1
15	Wall Mounting Frame	01252229	1
16	Motor Press Plate	26112515	1
17	Fan Motor	15012145	1
18	Connecting pipe clamp	26112514	1
19	Drainage Hose	0523001405	1
20	Stepping Motor	1521240212	1
21	Crank	73012005	1
22	Guide Louver	1051232001	1
23	Axile Bush	10542036	2
24	Electric Box	2011221105	1
25	Terminal Board	42011233	1
26	Electric Box Cover2	20112210	1
27	Main Board	300002060917	1
28	Display Board	30565278	1
29	Shield Cover of Electric Box	01592176	1
30	Electric Box Cover	20112209	1
31	Jumper cap	4202021925	1
32	Lower Shield of Electric Box	01592139	1
33	Electric Box Assy	100002069699	1
36	Temperature Sensor	3900031302	1
37	Remote Controller	305001000111	1
38	Rear Grill Sub-assy	/	/
37	Shield Cover of Electric Box Cover	01592176	1
38	Electric Box Cover	20112209	1
39	Detecting plate(WIFI)	30110144	1

Above data is subject to change without notice.

10.2 Outdoor Unit

GWH09QB-K6DNA1E/O

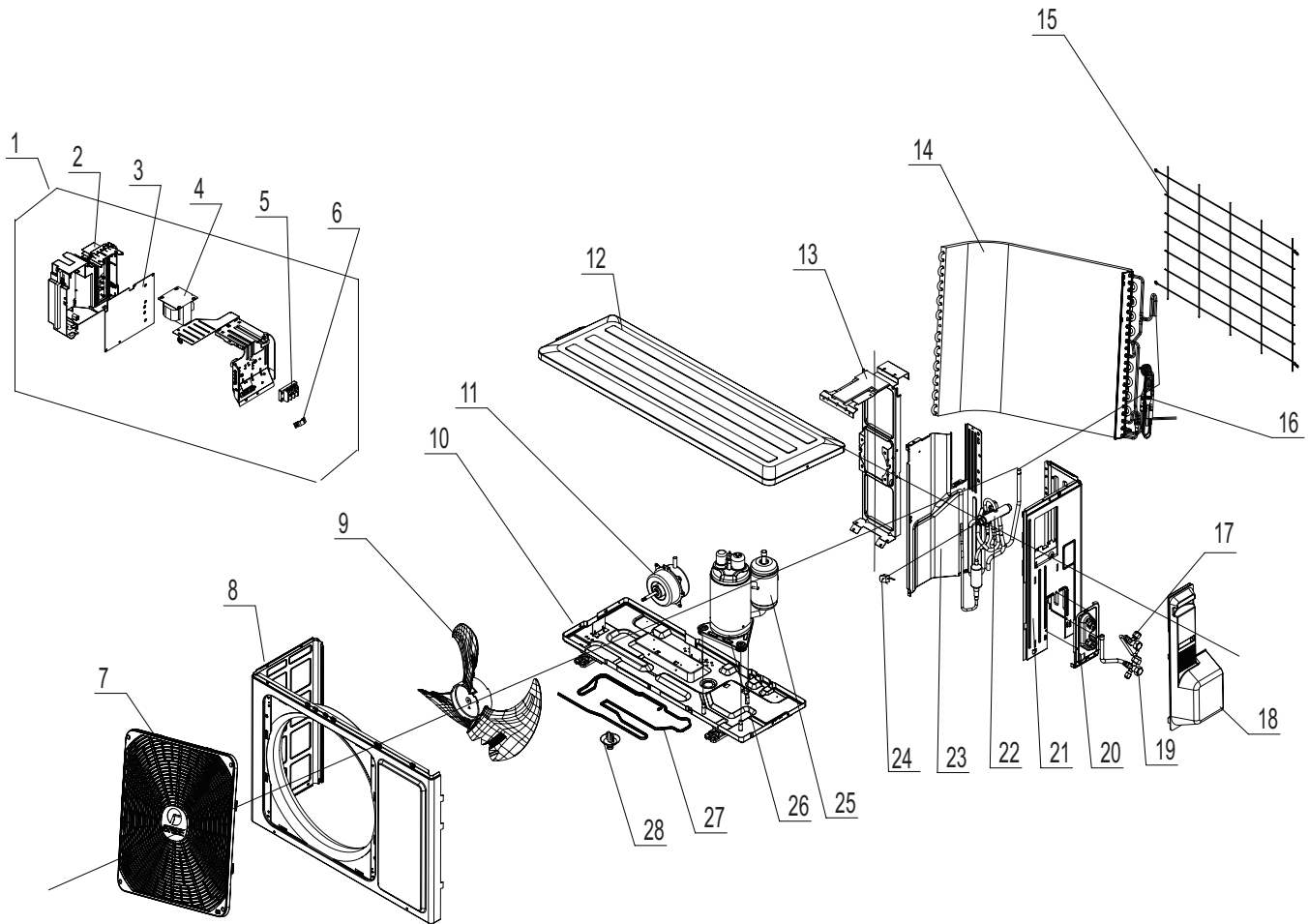

The component picture is only for reference; please refer to the actual product.

NO.	Description	Part Code		Qty
		GWH09QB-K6DNA1E/O		
		Product Code		
		CB419W15800	CB419W15801	
1	Electric Box Assy	100002061319	100002061410	1
2	Electric Box	20113034	20113034	1
3	Main Board	300027060176	300027060177	1
4	Reactor	43130184	43130184	1
5	Terminal Board	422000060016	422000060016	1
6	Wire Clamp	71010103	71010103	2
7	Front Grill	22413049	22413049	1
8	Front Panel	01533034P	01533034P	1
9	Axial Flow Fan	10333004	10333004	1
10	Chassis Sub-assy	017000060096	017000060102	1
11	Brushless DC Motor	1501308511	1501308511	1
12	Top Cover Sub-Assy	000051060006	000051060006	1
13	Motor Support	01703104	01703104	1
14	Condenser Assy	011002060205	011002060205	1
15	Rear Grill	01473009	01473009	1
16	Capillary Sub-assy	030006060170	030006060170	1
17	Cut off Valve	071302391	071302391	1
18	Big Handle	262334332	262334332	1
19	Cut off Valve	071302391	071302391	1
20	Valve Support	0171314201P	0171314201P	1
21	Right Side Plate Sub-Assy	0130317801	0130317801	1
22	4-Way Valve Assy	030152060087	030152060087	1
23	Clapboard Sub-Assy	0123338502	0123338502	1
24	Magnet Coil	4300040050	4300040050	1
25	Compressor and Fittings	009001060050	009001060050	1
26	Electrical Heater	/	/	/
27	Electrical Heater (Chassis)	7651000414	/	1
28	Drainage Connector	06123401	06123401	1

Above data is subject to change without notice.

GWH12QC-K6DNA1D/O GWH09YC-K6DNA1A/O GWH12YC-K6DNA1A/O GWH12QC-K6DNA5X/O

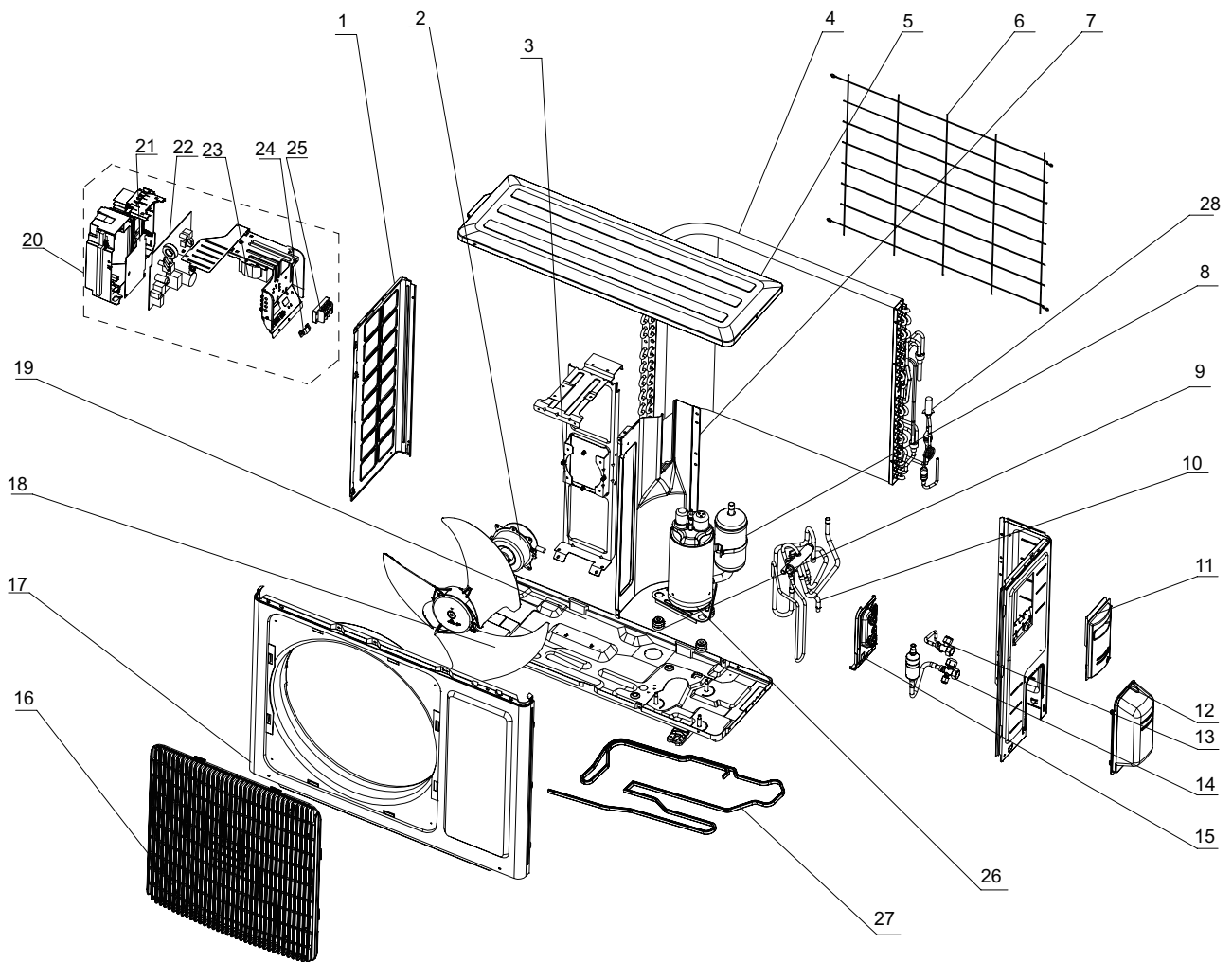

The component picture is only for reference; please refer to the actual product.

NO.	Description	Part Code		Qty
		GWH12QC-K6DNA1D/O		
		Product Code		
		CB419W15500	CB419W15501	
1	Left Side Plate	01303200P	01303200P	1
2	Fan Motor	1501308511	1501308511	1
3	Motor Support	01703136	01703136	1
4	Condenser Assy	011002060182	011002060182	1
5	Top Cover Sub-Assy	000051060003	000051060003	1
6	Rear Grill	01475014	01475014	1
7	Clapboard Sub-Assy	01233180	01233180	1
8	Compressor and Fittings	009001060066	009001060066	1
9	Compressor Gasket	76010083	76010083	3
10	4-Way Valve Assy	030152060069	030152060069	1
11	Big Handle	2623343106	2623343106	1
12	Valve Cover	22243006	22243006	1
13	Cut off Valve	071302391	071302391	1
14	Cut off Valve	07130239	07130239	1
15	Valve Support	0171314201P	0171314201P	1
16	Front Grill	22413047	22413047	1
17	Cabinet	01433033P	01433033P	1
18	Axial Flow Fan	10333011	10333011	1
19	Chassis Sub-assy	017000060080P	017000060083P	1
20	Electric Box Assy	100002061044	100002061041	1
21	Electric Box	20113034	20113034	1
22	Main Board	300027060161	300027060162	1
23	Reactor	43130184	43130184	1
24	Wire Clamp	71010103	71010103	1
25	Terminal Board	422000060016	422000060016	1
26	Electrical Heater	/	/	/
27	Electrical Heater (Chassis)	7651000414	/	1
28	Electric Expansion Valve Sub-Assy	030026060094	030026060094	1

Above data is subject to change without notice.

NO.	Description	Part Code			Qty
		GWH09YC-K6DNA1A/O	GWH12YC-K6DNA1A/O	GWH12QC-K6DNA5X/O	
	Product Code	CB437W01600	CB437W01100	CB425W15500	
1	Left Side Plate	01303200P	01303200P	01303200P	1
2	Fan Motor	1501308507	1501308511	1501308511	1
3	Motor Support	01703136	01703136	01703136	1
4	Condenser Assy	011002000239	011002000245	011002060182	1
5	Top Cover Sub-Assy	01253081	01253081	000051060094	1
6	Rear Grill	01475014	01475014	01475014	1
7	Clapboard Sub-Assy	01233180	01233180	01233180	1
8	Compressor and Fittings	00103925G	00103925G	009001060066	1
9	Compressor Gasket	76710287	76710287	76010083	3
10	4-Way Valve Assy	030152000158	030152000137	030152060069	1
11	Big Handle	2623343106	2623343106	2623343106	1
12	Valve Cover	22243006	22243006	22243006	1
13	Cut off Valve	0713379101	03005700067	071302391	1
14	Cut off Valve	07133474	07133474	07130239	1
15	Valve Support	0171314201P	0171314201P	0171314201P	1
16	Front Grill	22413044	22413044	22413047	1
17	Cabinet	01433033P	01433033P	01433033P	1
18	Axial Flow Fan	10333011	10333011	10333011	1
19	Chassis Sub-assy	02803213P	02803213P	017000060083P	1
20	Electric Box Assy	10000100925	10000100913	100002061041	1
21	Electric Box	20113032	20113032	20113034	1
22	Main Board	300027000103	300027000079	300027060162	1
23	Reactor	43130184	43130184	43130184	1
24	Wire Clamp	71010103	71010103	71010103	1
25	Terminal Board	42010313	42010313	422000060016	1
26	Electrical Heater	/	/	/	/
27	Electrical Heater (Chassis)	/	/	/	/
28	Electric Expansion Valve Sub-Assy	030026000115	030026000119	030026060094	1

Above data is subject to change without notice.

No.	Description	Part Code		Qty
		GWH18QD-K6DNA1D/O		
		Product Code	CB419W15600	
1	Front Grill	22413045	22413045	1
2	Front Panel	01535013P	01535013P	1
3	Drainage Connector	06123401	06123401	1
4	Chassis Sub-assy	02803270P	02803270P	1
5	Drainage Joint	06813401	06813401	1
6	Compressor and Fittings	009001060006	009001060006	1
7	Magnet Coil	4300876704	4300876704	1
8	4-Way Valve Assy	030152060089	030152060089	1
9	Cut off Valve Assy	030164000042	030164000042	1
10	Cut off Valve Sub-Assy	0713506803	0713506803	1
11	Valve support assy	01715010P	01715010P	1
12	Right Side Plate	0130509402P	0130509402P	1
13	Valve Support	22245002	22245002	1
14	Handle	26233053	26233053	1
15	Wire Clamp	26115004	26115004	1
16	Rear Grill	01473043	01473043	1
17	Condenser Assy	011002060187	011002060187	1
18	Reactor	/	/	/
19	Clapboard Sub-Assy	01233153	01233153	1
20	Coping	012049000007P	012049000007P	1
21	Supporting Board(Condenser)	01795010	01795010	1
22	Motor Support Sub-Assy	01705036	01705036	1
23	Fan Motor	1501506402	1501506402	1
24	Axial Flow Fan	10335008	10335008	1
25	Left Side Plate	01305093P	01305093P	1
26	Left handle	26233053	26233053	1
27	Electric Box Assy	100002061293	100002061293	1
28	Wire Clamp	71010003	71010003	1
29	Terminal Board	422000060009	422000060009	1
30	Electric Box	20113027	20113027	1
31	Radiator	49013060	49013060	1
32	Main Board	300027060172	300027060172	1
33	Insulated Board (Cover of Electric Box)	20113003	20113003	1
34	Temperature Sensor	3900030901	3900030901	1
35	Electronic Expansion Valve assy	030174060025	030174060025	1

Above data is subject to change without notice.

No.	Description	Part Code		Qty
		GWH24QE-K6DNA1E/O		
		Product Code	CB419W15700	
1	Front Grill	22415010	22415010	1
2	Front Panel	01535013P	01535013P	1
3	Drainage Connector	06123401	06123401	1
4	Chassis Sub-assy	0120581601P	01205816P	1
5	Drainage Joint	06813401	06813401	1
6	Compressor and Fittings	009001000195	009001000195	1
7	Magnet Coil	4300040087	4300040087	1
8	4-Way Valve Assy	03073274	03073274	1
9	Cut off Valve Assy	07133833	07133833	1
10	Cut off Valve Sub-Assy	07133843	07133843	1
11	Valve support assy	0130509001P	0130509001P	1
12	Right Side Plate	01705046P	01705046P	1
13	Valve Support	22245002	22245002	1
14	Handle	26233053	26233053	1
15	Wire Clamp	/	/	/
16	Rear Grill	01475020	01475020	1
17	Condenser Assy	011002000244	011002000244	1
18	Reactor	/	/	/
19	Clapboard Sub-Assy	01235081	01235081	1
20	Coping	012049000007P	012049000007P	1
21	Supporting Board(Condenser)	01795031	01795031	1
22	Motor Support Sub-Assy	01705067	01705067	1
23	Fan Motor	1501506402	1501506402	1
24	Axial Flow Fan	10335008	10335008	1
25	Left Side Plate	01305093P	01305093P	1
26	Left handle	26233053	26233053	1
27	Electric Box Assy	100002061454	100002061457	1
28	Wire Clamp	71010102	71010102	1
29	Terminal Board	422000060009	422000060009	1
30	Electric Box	20115003	20115003	1
31	Radiator	4901521502	4901521502	1
32	Main Board	300027060182	300027060184	1
33	Insulated Board (Cover of Electric Box)	20113003	20113003	1
34	Temperature Sensor	3900030902	3900030902	1
35	Electronic Expansion Valve assy	030174000049	030174000049	1

Above data is subject to change without notice.

No.	Description	Part Code		Qty
		GWH18QD-K6DNA5X/O	GWH24QE-K6DNA5X/O	
	Product Code	CB425W15300	CB425W15400	
1	Front Grill	22413045	22413045	1
2	Front Panel	01535013P	01535013P	1
3	Drainage Connector	06123401	06123401	1
4	Chassis Sub-assy	02803231P	01205816P	1
5	Drainage Joint	06123401	06123401	1
6	Compressor and Fittings	009001060006	009001000195	1
7	Magnet Coil	07200200001202	4300040087	1
8	4-Way Valve Assy	030152060089	03073274	1
9	Cut off Valve Assy	07133774	07133833	1
10	Cut off Valve Sub-Assy	0713506803	07133843	1
11	Valve support assy	01715010P	0130509001P	1
12	Right Side Plate	0130509402P	0130509001P	1
13	Valve Support	22245002	01705047	1
14	Handle	26233053	26233053	1
15	Wire Clamp	71010003	71010102	/
16	Rear Grill	01473043	01475020	1
17	Condenser Assy	011002060187	011002000244	1
18	Reactor	/	/	/
19	Clapboard Sub-Assy	01232902	01235081	1
20	Coping	012049000007P	012049000007P	1
21	Supporting Board(Condenser)	01795010	01795031	1
22	Motor Support Sub-Assy	01705036	01705067	1
23	Fan Motor	1501506402	1501506402	1
24	Axial Flow Fan	10335008	10335008	1
25	Left Side Plate	01305093P	01305093P	1
26	Left handle	26233053	26233053	1
27	Electric Box Assy	100002061310	100002061457	1
28	Wire Clamp	71010003	71010102	1
29	Terminal Board	422000060009	422000060009	1
30	Electric Box	20113027	20115003	1
31	Radiator	49010252	4901521502	1
32	Main Board	300027060171	300027060184	1
33	Insulated Board (Cover of Electric Box)	20113003	20113003	1
34	Temperature Sensor	3900030901	3900030902	1
35	Electronic Expansion Valve assy	030174060025	030174000085	1

Above data is subject to change without notice.

NO.	Description	Part Code		Qty
		GWH18YD-K6DNA1A/O	GWH24YE-K6DNA1A/O	
		Product Code		
		CB437W01300	CB437W01400	
1	Front Grill	22413045	22415010	1
2	Front Panel	01535013	01535013P	1
3	Drainage Connector	06123401	06123401	1
4	Chassis Sub-assy	02803231P	01205816P	1
5	Drainage hole Cap	06813401	06813401	3
6	Compressor and fittings	00103919G	00103920	1
7	Magnet Coil	4300040045	4300040087	1
8	4-Way Valve Assy	03015200069	03073274	1
9	Cut off Valve Assy	07133774	07133844	1
10	Cut off Valve Sub-Assy	07133204	07133843	1
11	Valve support assy	01715010P	01705046P	1
12	Right Side Plate	0130509402P	0130509001P	1
13	Valve cover	2623525404	22245002	1
14	Handle	26233053	26233053	1
15	Wiring Clamp	26115004	26115005	1
16	Rear Grill	01473043	01475020	1
17	Condenser Assy	011002000308	011002000244	1
18	Reactor	/	/	/
19	Clapboard Assy	01233153	01235081	1
20	Coping	01255005P	012049000007P	1
21	Supporting Board(Condenser)	01795010	01795031	1
22	Motor Support Sub-Assy	01705036	01705067	1
23	Fan Motor	1501506402	1501506402	1
24	Axial Flow Fan	10335008	10335008	1
25	Left Side Plate	01305093P	01305093P	1
26	left handle	22245002	2623525404	1
27	Electric Box Assy	100002000414	100002000470	1
28	Wire Clamp	71010003	71010102	1
29	Terminal Board	420101943	422000060009	1
30	Electric Box	20113027	20115003	1
31	Radiator	49013060	4901521502	1
32	Main Board	300027000083	300027000081	1
33	Insulated Board (Cover of Electric Box)	20113003	/	1
34	Temperature Sensor	3900030901	3900030902	1
35	Electric Expansion Valve Sub-Assy	030174000058	030174000049	1

Above data is subject to change without notice.

GWH09AGA-K6DNA1A/O GWH12AGB-K6DNA1A/O

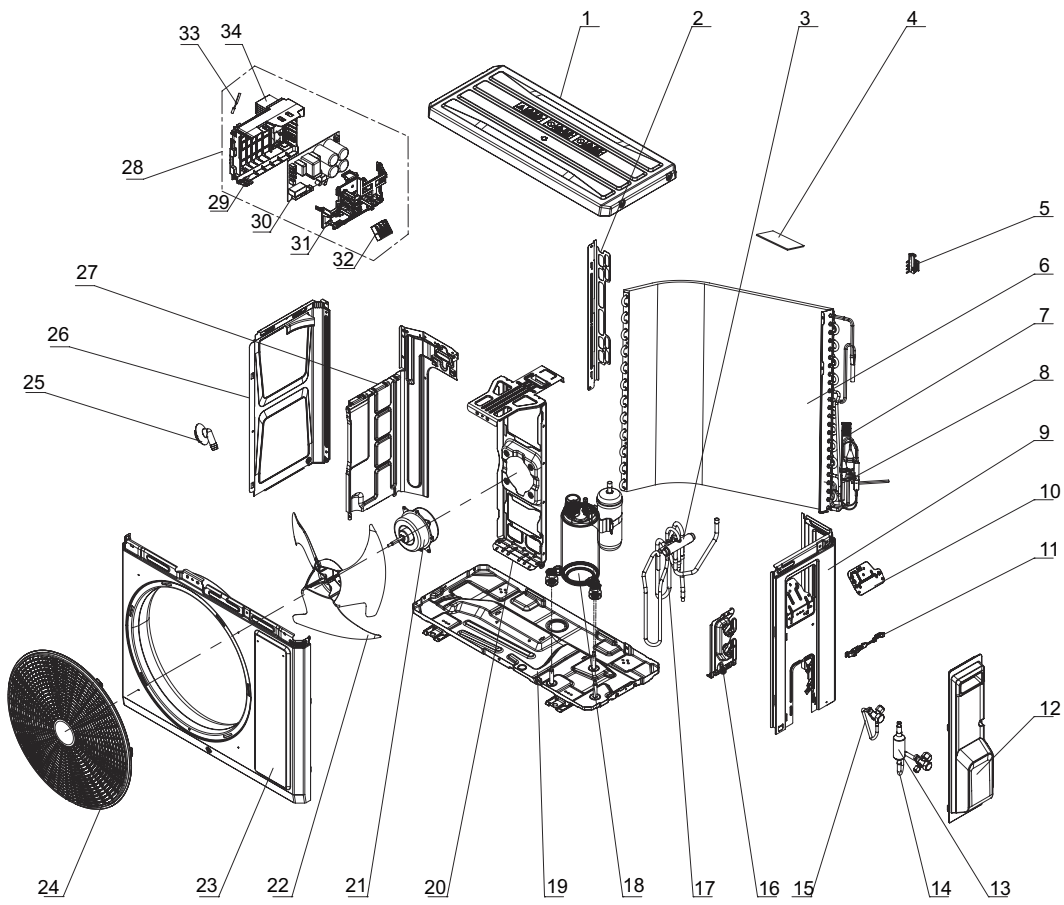

The component is only for reference; please refer to the actual product.

No.	Description	Part Code		Qty
		GWH09AGA-K6DNA1A/O	GWH12AGB-K6DNA1A/O	
	Product Code	CB385W01000	CB385W01700	
1	Coping	01204906008701P	01204906008701P	1
2	Supporting Board(Condenser)	012072061032	012072061032	1
3	4-Way Valve	430004022	430004022	1
4	Sponge(Condenser)	1212309101	1212309101	1
5	Temperature Sensor Support	24213042	24213042	1
6	Condenser Assy	011002061289	011002061317	1
7	Capillary Sub-assy	030006060901	030006060915	1
8	Sensor Insert	42020063	42020063	1
9	Right Side Plate	01205606031101P	01205606031101P	1
10	Earthing Plate Sub-assy	012002060009	012002060009	1
11	Wire Clamp	71010103	71010103	1
12	Handle Assy	000223000006	000223000006	1
13	Silencer	07243067	07243067	1
14	Cut-off valve 1/4(N)	07000106001501	07000106001501	1
15	Cut-off valve 3/8(N)	07000106001401	07000106001401	1
16	Valve Support	012044060018P	012044060018P	1
17	4-Way Valve Assy	030152060486	030152060486	1
18	Compressor and Fittings	009001060484	009001060497	1
19	Chassis Sub-assy	017000060511P	017000060511P	1
20	Motor Support	01204806011103	01204806011103	1
21	Brushless DC Motor	1501308517	1501308517	1
22	Axial Flow Fan	10333428	10333428	1
23	Cabinet	012022060007P	012022060007P	1
24	Front Grill	200057060007	200057060007	1
25	Drainage Joint(ODU)	26113009	26113009	1
26	Left Side Plate	012055060256P	012055060256P	1
27	Clapboard	017021060544	017021060544	1
28	Electric Box Assy	100002069939	100002070042	1
29	Electric Box	200013060073	200013060073	1
30	Main Board	300027061312	300027061355	1
31	Electric Box Cover	200082060058	200082060058	1
32	Terminal Board	422000060016	422000060016	1
33	Temperature Sensor	3900030907	3900030907	1
34	Radiator	430034060108	430034060108	1

Above data is subject to change without notice.

11. Removal Procedure

Caution: discharge the refrigerant completely before removal.

11.1 Removal Procedure of Indoor Unit

09/12K

Note: Take A1 Panel for example.

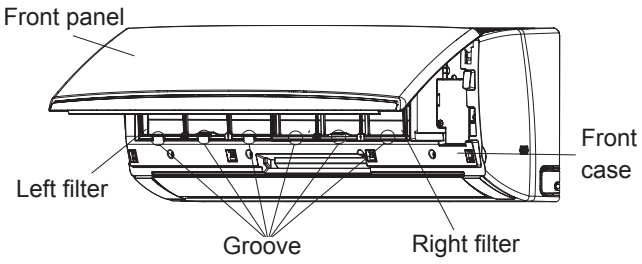
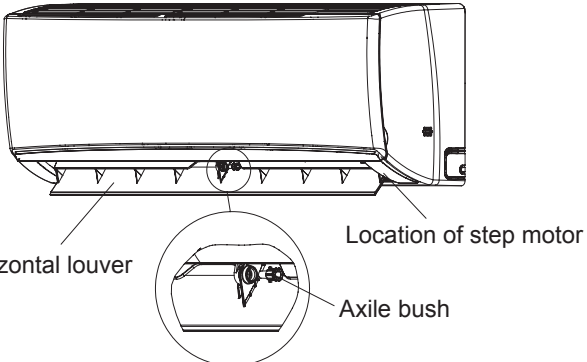
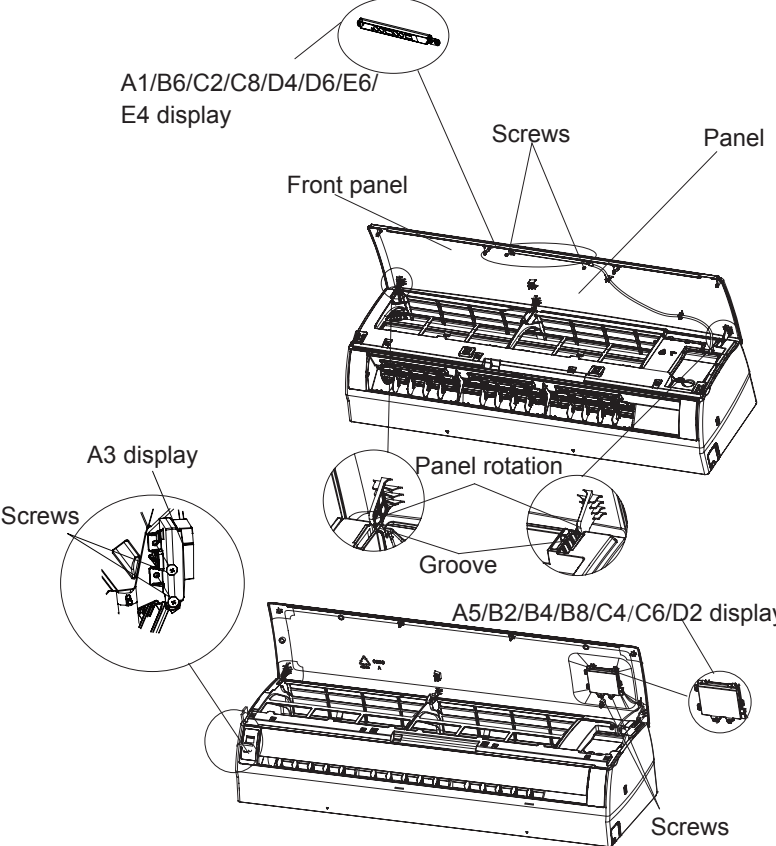
Step	Procedure	
1. Remove filter assembly	<p>Open the front panel. Push the left filter and right filter until they are separate from the groove on the front panel. Remove the left filter and right filter respectively.</p>	
2. Remove horizontal louver	<p>Push out the axle bush on horizontal louver. Bend the horizontal louver with hand and then separate the horizontal louver from the crankshaft of step motor to remove it.</p>	
3. Remove panel	<p>a</p> <p>① A1/B6/C2/C4 display: Screw off the 2 screws that are locking the display board. Separate the display board from the front panel.</p> <p>② A2/A3 display: Screw off the 2 screws that are locking the display board. This display can be disassembled only after removing the front case (refer to step 5 of disassembly).</p> <p>③ A5/B2/B4/B8/C6/D2 display: Screw off the 2 screws that are locking the display board.</p> <p>b</p> <p>Separate the panel rotation shaft from the groove fixing the front panel and then removes the front panel.</p>	

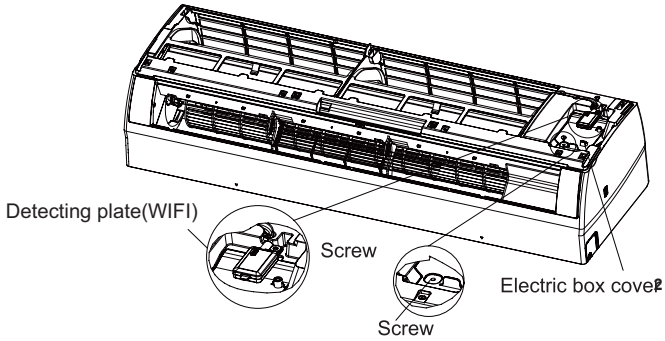
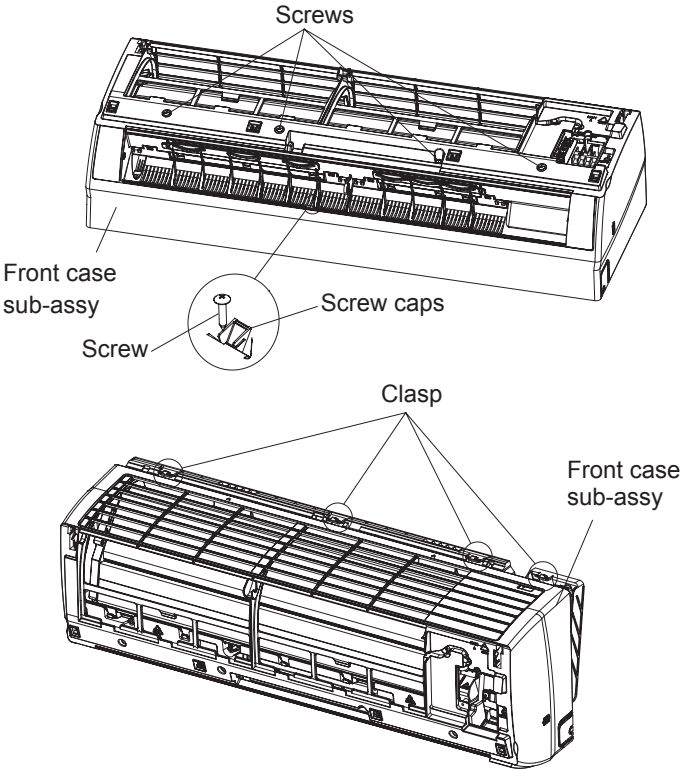
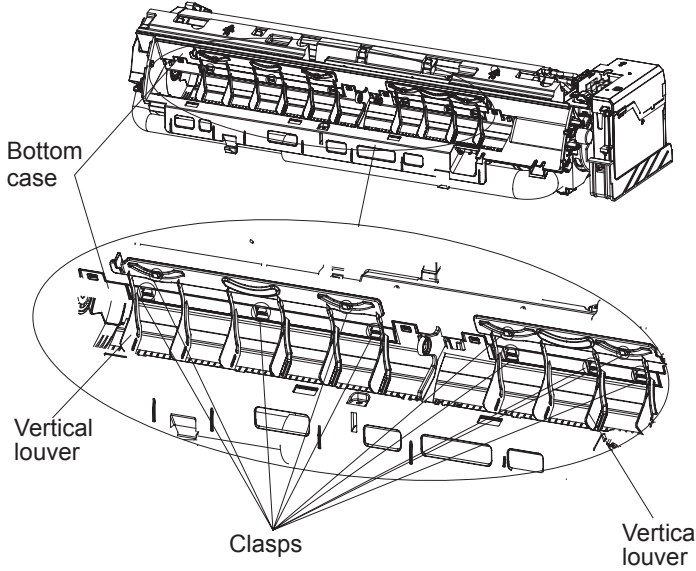
Step	Procedure	Image
4. Remove detecting plate(wifi) and electric box cover2	<p>Remove the screws fixing detecting plate and remove detecting plate(wifi).</p> <p>Remove the screws fixing electric box cover2 and remove electric box2.</p>	
5. Remove front case sub-assy	<p>a Remove the screws fixing front case.</p> <p>Note: 1. Open the screw caps before removing the screws around the air outlet. 2. The quantity of screws fixing the front case sub-assy is different for different models.</p> <p>b Loosen the connection clasps between front case sub-assy and bottom case. Lift up the front case sub-assy and take it out.</p>	
6. Remove vertical louver	<p>Loosen the connection clasps between vertical louver and bottom case to remove vertical louver.</p>	

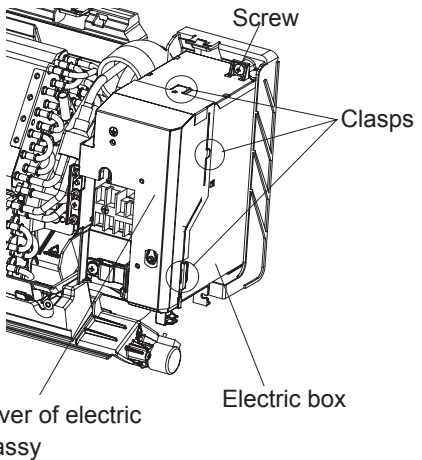
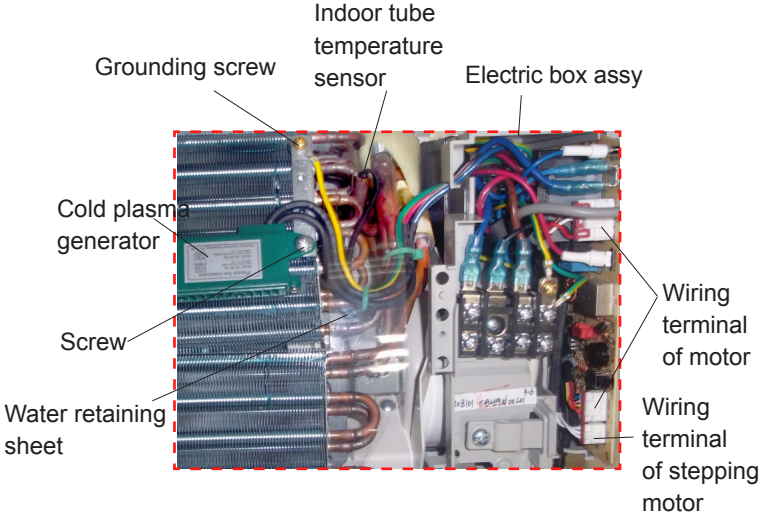
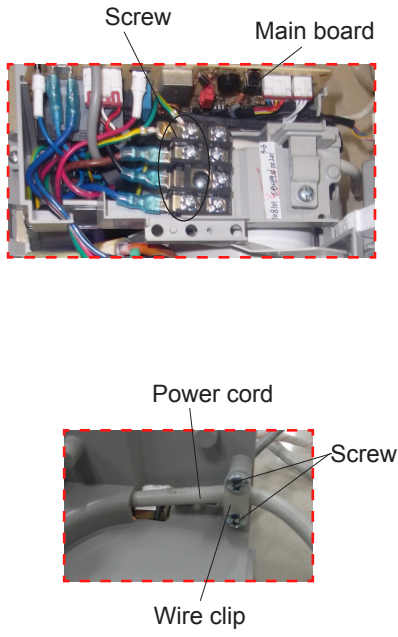
Step	Procedure
7. Remove electric box assy	
a	<p>Loosen the connection clasps between shield cover of electric box sub-assy and electric box, and then remove the shield cover of electric box sub-assy. Remove the screw fixing electric box assy .</p>  <p>The diagram shows a perspective view of the electric box assembly. A shield cover is attached to the main electric box via two clasps and a screw. Labels include: Screw, Clasps, Shield cover of electric box sub-assy, and Electric box.</p>
b	<p>① Take off the water retaining sheet. Remove the cold plasma generator by screwing off the locking screw on the generator. ② Take off the indoor tube temperature sensor. ③ Screw off 1 grounding screw. ④ Remove the wiring terminals of motor and stepping motor. ⑤ Remove the electric box assy.</p>  <p>The photograph shows the internal components of the unit. Labels include: Grounding screw, Indoor tube temperature sensor, Electric box assy, Cold plasma generator, Screw, Water retaining sheet, Wiring terminal of motor, and Wiring terminal of stepping motor.</p>
c	<p>Twist off the screws that are locking each lead wire and rotate the electric box assy. Twist off the screws that are locking the wire clip. Loosen the power cord and remove its wiring terminal. Lift up the main board and take it off.</p>  <p>The photograph shows the main board and power cord assembly. Labels include: Screw, Main board, Power cord, Wire clip, and Screw.</p>

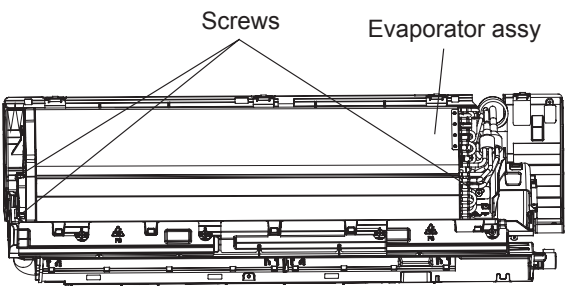
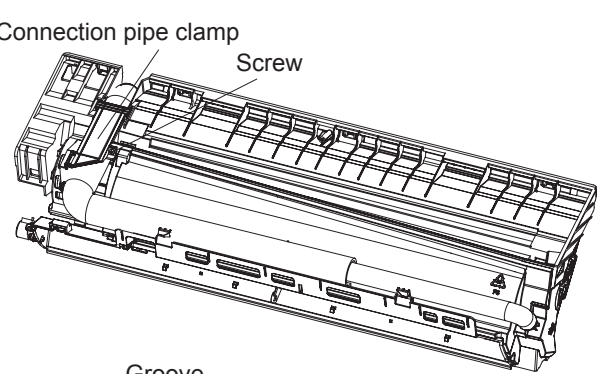
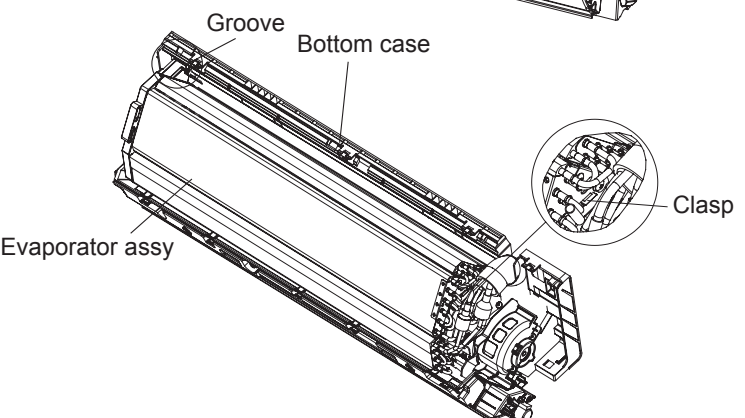
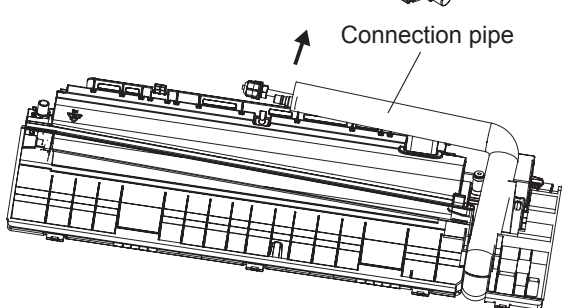
Step	Procedure	
	<p>Instruction: Some wiring terminal of this product is with lock catch and other devices. The pulling method is as below:</p> <p>1.Remove the soft sheath for some terminals at first, hold the circlip and then pull out the terminals.</p> <p>2.Pull out the holder for some terminals at first (holder is not available for some wiring terminal), hold the connector and then pull the terminal.</p>	 <p>Labels: circlip, soft sheath, holder, connector</p>
8. Remove evaporator assy		
a	Remove 3 screws fixing evaporator assy.	 <p>Labels: Screws, Evaporator assy</p>
b	At the back of the unit, remove the screw fixing connection pipe clamp and then remove the connection pipe clamp.	 <p>Labels: Connection pipe clamp, Screw</p>
c	First remove the left side of the evaporator from the groove of bottom case and then remove the right side from the clasp on the bottom case.	 <p>Labels: Groove, Bottom case, Evaporator assy, Clasp</p>
d	Adjust the position of connection pipe on evaporator slightly and then lift the evaporator upwards to remove it.	 <p>Labels: Connection pipe</p>

Step	Procedure
9. Remove motor and cross flow blade	
a	<p>Remove the screws fixing motor clamp and then remove the motor clamp.</p>
b	<p>Remove the screws at the connection place of cross flow blade and motor; lift the motor and cross flow blade upwards to remove them. Remove the bearing holder sub-assy. Remove the screw fixing step motor and then remove the step motor.</p>

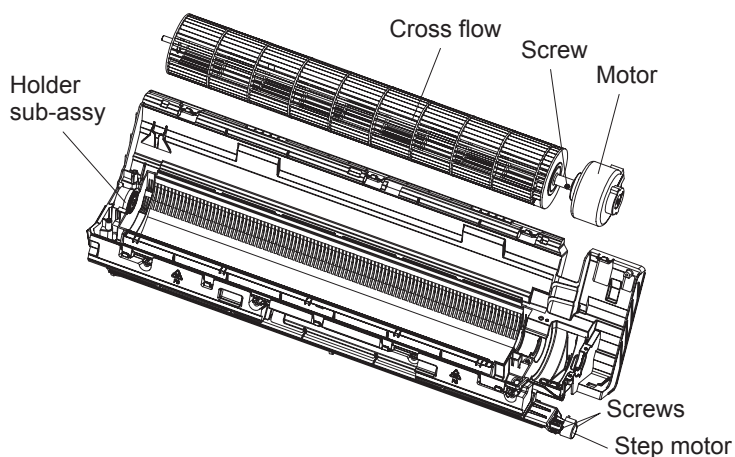
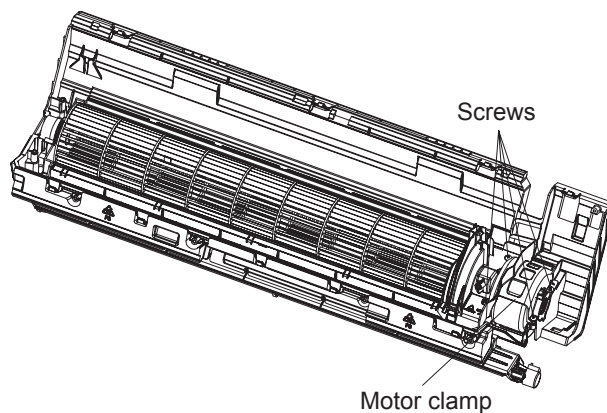

18/24K

Note: Take A1 Panel for example.

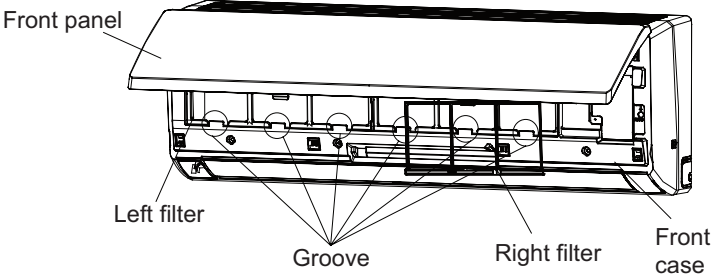
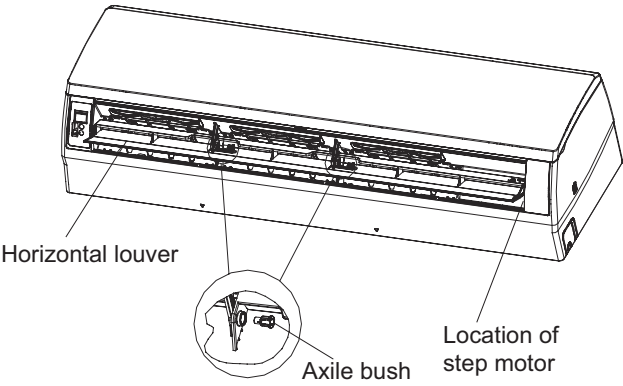
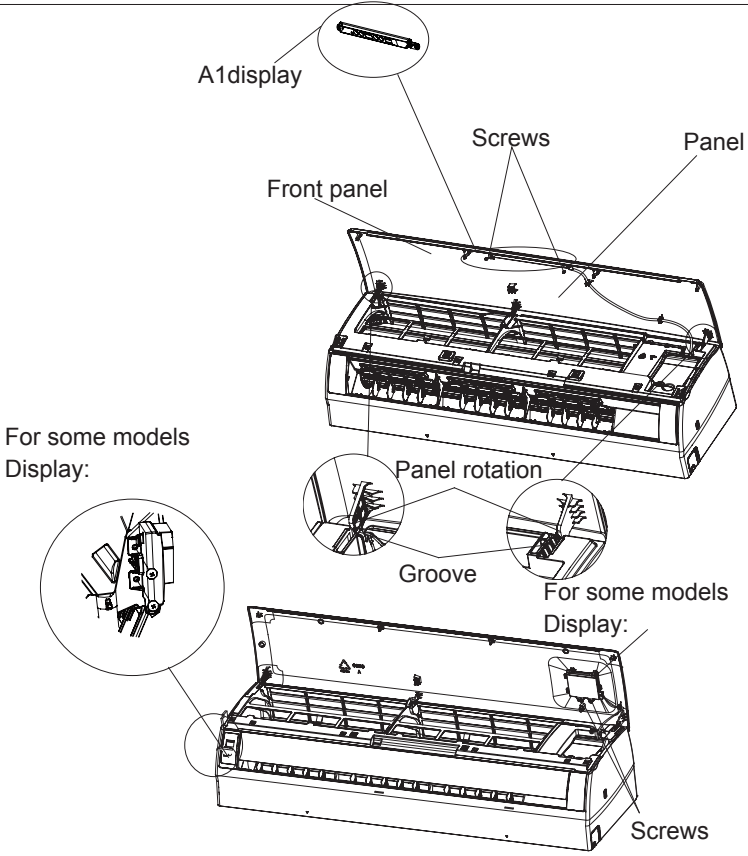
Step	Procedure
<p>1. Remove filter assembly</p>	<p>Open the front panel. Push the left and right filters to make them break away from the groove on the front case. Then remove the left and right filters one by one.</p> 
<p>2. Remove horizontal louver</p>	<p>Push out the axle bush on horizontal louver, bend the horizontal louver with hand and then separate the horizontal louver from the crank shaft of step motor to remove it.</p> 
<p>3. Remove panel and display</p>	<p>Separate the panel rotation shaft from the groove fixing the front panel and then remove the front panel.</p> <p>Screw off the 2 screws that are locking the display board.</p> 

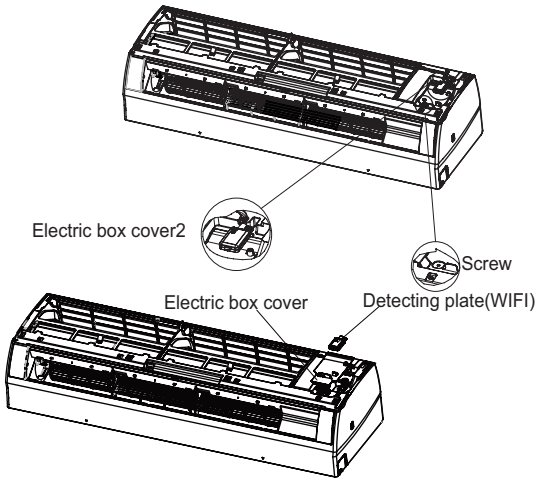
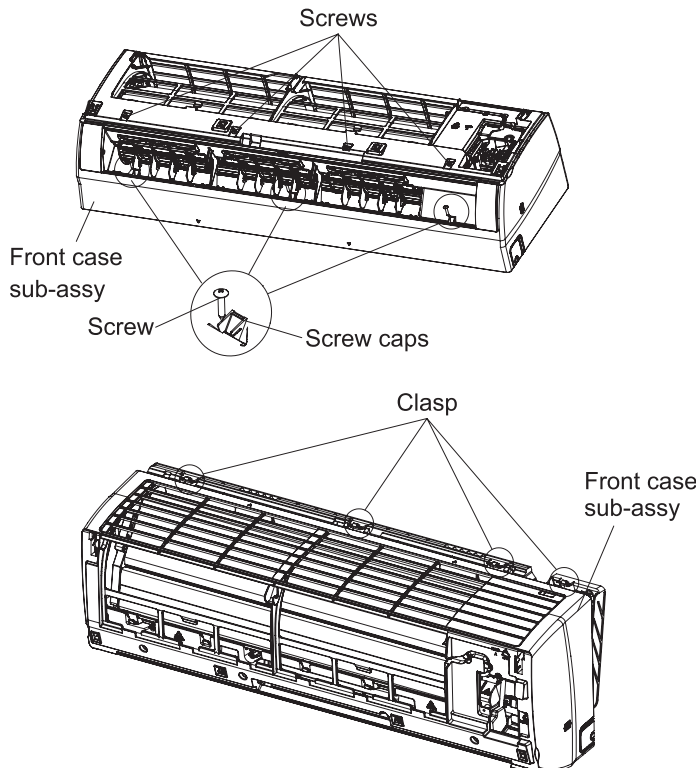
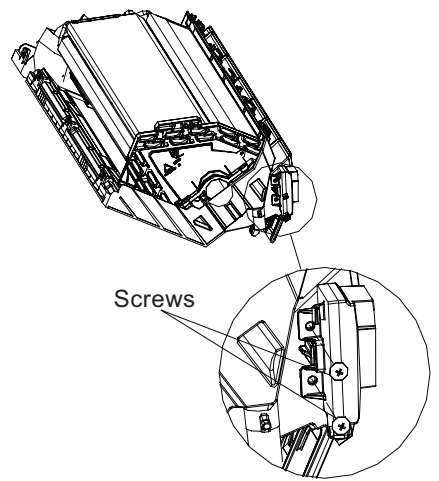
Step	Procedure	Diagram
<p>4.Remove electric box cover 2</p>	<p>Remove the screws on the electric box cover 2 and detecting plate(WIFI), then remove the electric box cover 2 and detecting plate(WIFI).</p> <p>Note:The position of detection board(WIFI) may be different for different models.</p>	 <p>Electric box cover2</p> <p>Electric box cover</p> <p>Detecting plate(WIFI)</p> <p>Screw</p>
<p>5.Remove front case sub-assy</p>	<p>Remove the screws fixing front case.</p> <p>Note:</p> <p>① Open the screw caps before removing the screws around the air outlet.</p> <p>② The quantity of screws fixing the front case sub-assy is different for different models.</p> <p>b Loosen the connection clasps between front case sub-assy and bottom case. Lift up the front case sub-assy and take it out.</p>	 <p>Screws</p> <p>Front case sub-assy</p> <p>Screw</p> <p>Screw caps</p> <p>Clasp</p> <p>Front case sub-assy</p>
<p>6.Remove display</p>	<p>Screw off the 2 screws that are locking the display board.</p>	 <p>Screws</p>

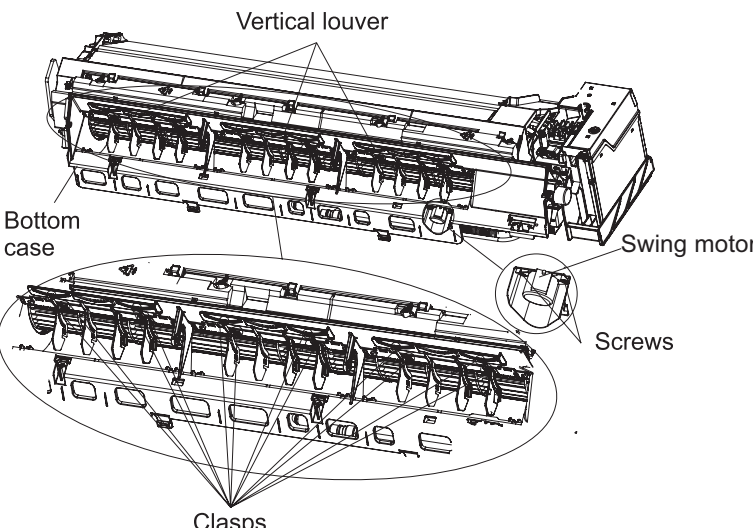
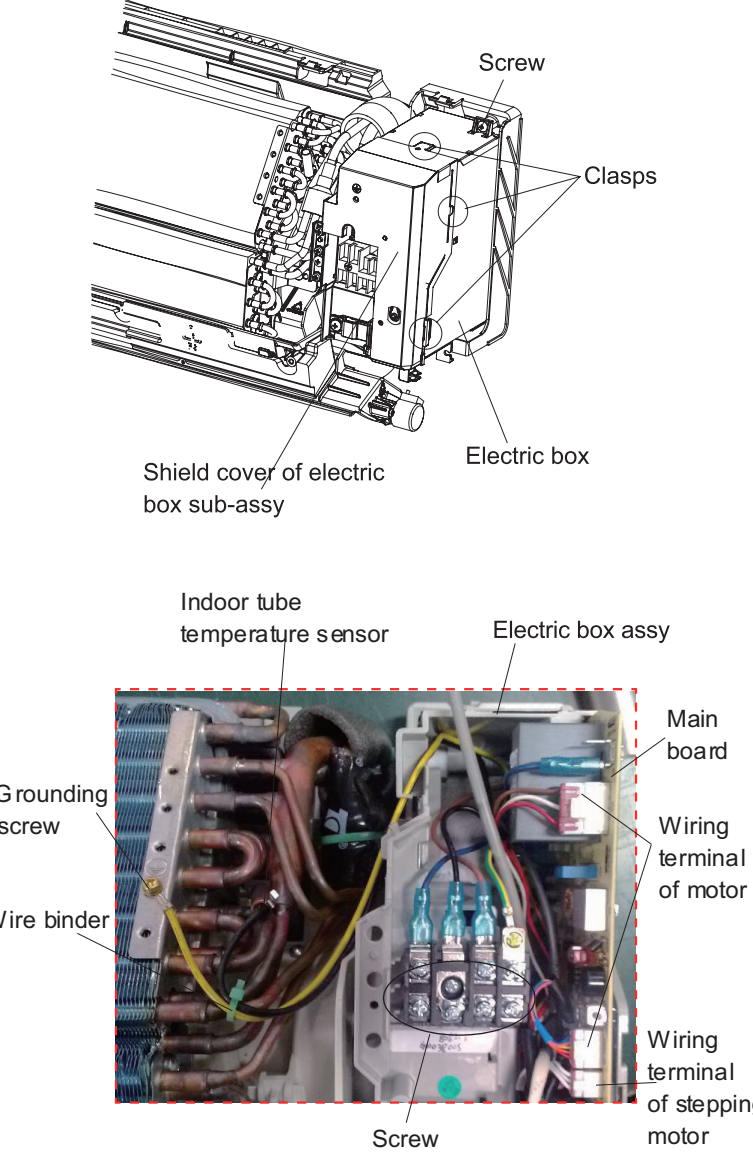
Step	Procedure	
7.Remove vertical louver	<p>a Loosen the connection clasps between vertical louver and bottom case to remove vertical louver.</p> <p>b Screw off the screws that are locking the swing motor and take the motor off.</p>	
8.Remove electric box assy	<p>a Loosen the connection clasps between shield cover of electric box sub-assy and electric box, and then remove the shield cover of electric box sub-assy. Remove the screw fixing electric box assy.</p> <p>b</p> <ol style="list-style-type: none"> ① Cut off the wire binder and pull out the indoor tube temperature sensor. ② Screw off one grounding screw. ③ Remove the wiring terminals of motor and stepping motor. ④ Remove the electric box assy. ⑤ Screw off the screws that are locking each lead wire. 	

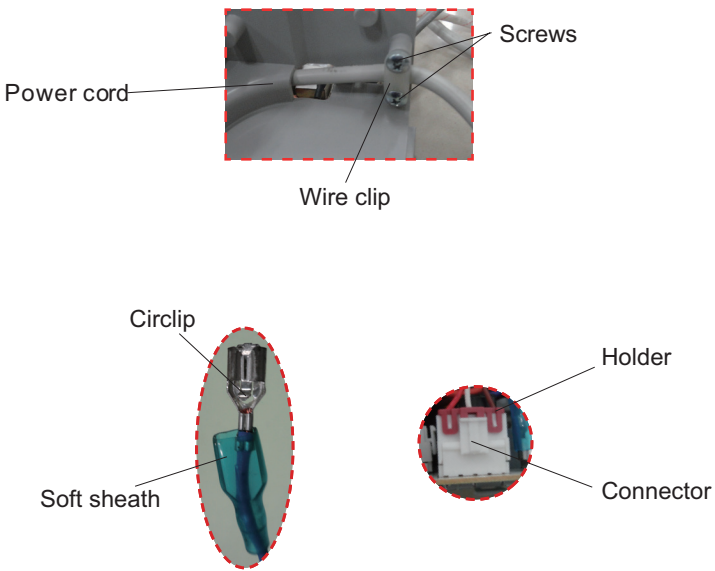
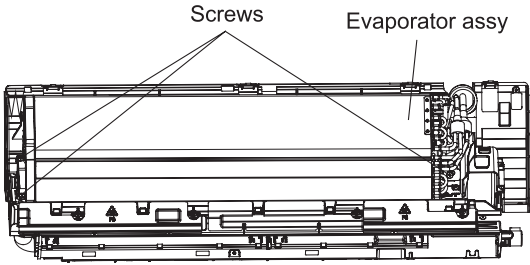
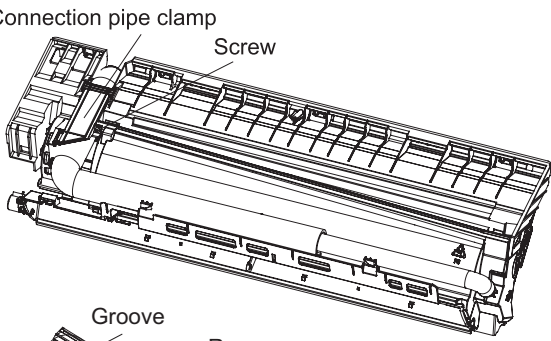
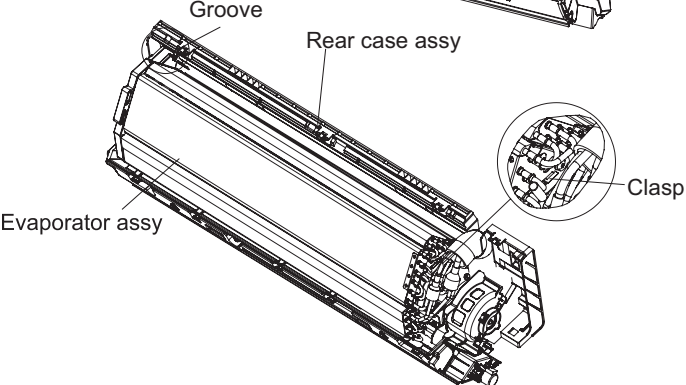
Step	Procedure	
c	<p>Rotate the electric box assy. Twist off the screws that are locking the wire clip and loosen the power cord. Remove the wiring terminal of power cord. Lift up the main board and take it off.</p> <p>Instruction: Some wiring terminal of this product is with lock catch and other devices. The pulling method is as below:</p> <p>① Remove the soft sheath for some terminals at first, hold the circlip and then pull out the terminals,</p> <p>② Pull out the holder for some terminals at first (holder is not available for some wiring terminal). hold the connector and then pull the terminal.</p>	 <p>Power cord</p> <p>Screws</p> <p>Wire clip</p> <p>Circlip</p> <p>Soft sheath</p> <p>Holder</p> <p>Connector</p>
9.Remove evaporator assy		
a	Remove 3 screws fixing evaporator assy.	 <p>Screws</p> <p>Evaporator assy</p>
b	At the back of the unit, remove the screw fixing connection pipe clamp and then remove the connection pipe clamp.	 <p>Connection pipe clamp</p> <p>Screw</p>
c	First remove the left side of evaporator from the groove on the rear case assy. Then remove the right side from the clasp on the rear case assy.	 <p>Groove</p> <p>Rear case assy</p> <p>Clasp</p> <p>Evaporator assy</p>

11.2 Removal Procedure of Outdoor Unit

GWH09QB-K6DNA1E/O

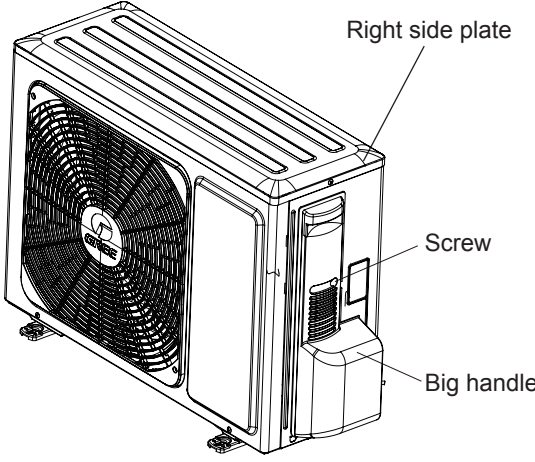
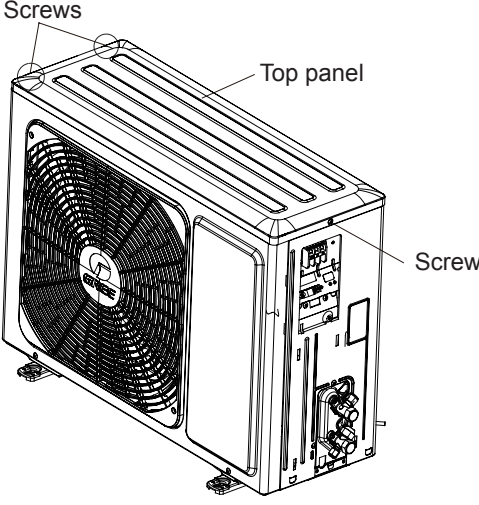
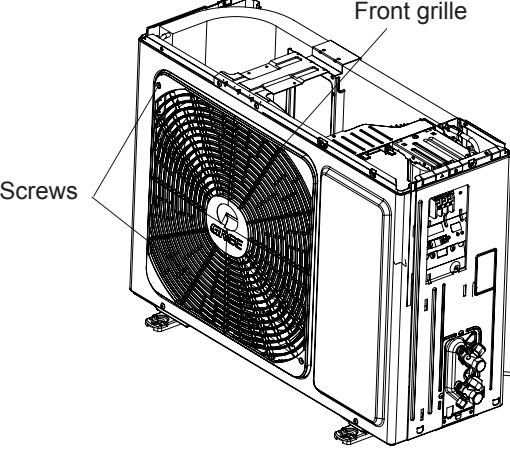
Step	Procedure
1. Remove big handle	<p>Remove the screw fixing big handle; slide out the big handle upwards to make the clasp of big handle separate from the groove of right side plate, and then remove the big handle.</p> 
2. Remove top panel	<p>Remove the screws fixing top panel and then remove the top panel.</p> 
3. Remove front grille	<p>Remove connection screws between the front grille and the front panel. Then remove the front grille.</p> 

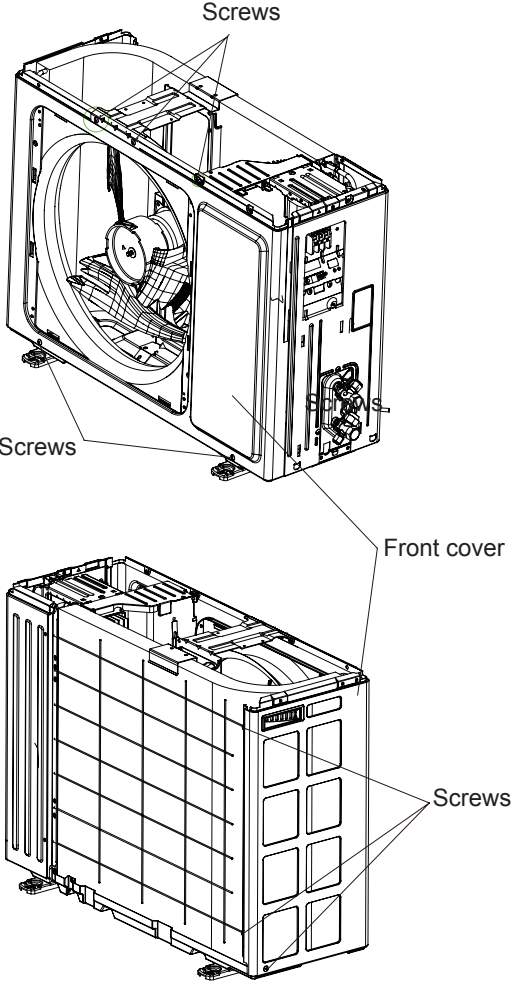
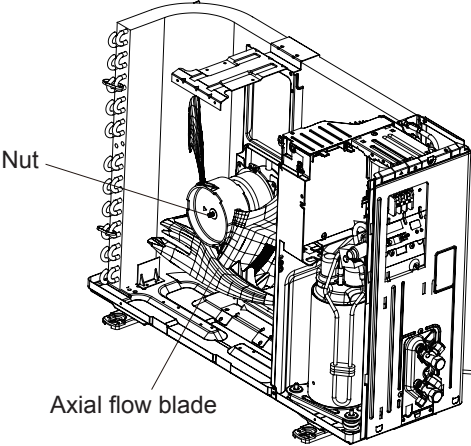
Step	Procedure
<p data-bbox="120 220 402 248">4. Remove the front cover</p>	<p data-bbox="228 345 719 406">Screw off the screws that are locking the front cover. Then take it off.</p> 
<p data-bbox="120 1378 412 1406">5. Remove axial flow blade</p>	<p data-bbox="228 1480 708 1541">Remove the nut fixing axial flow blade and then remove the axial flow blade.</p> 

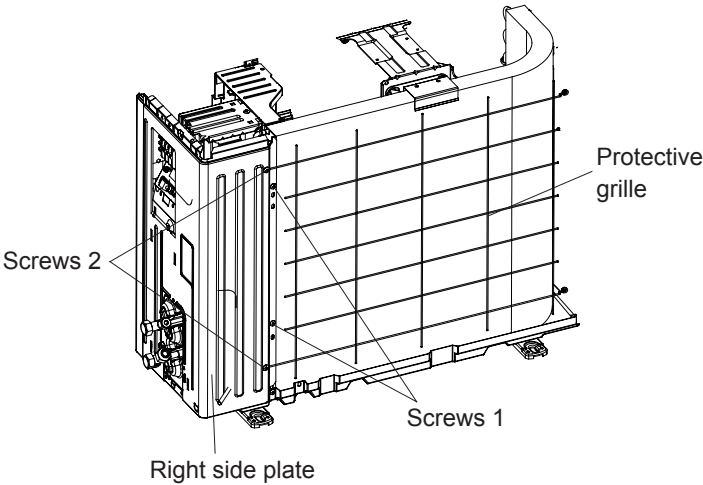
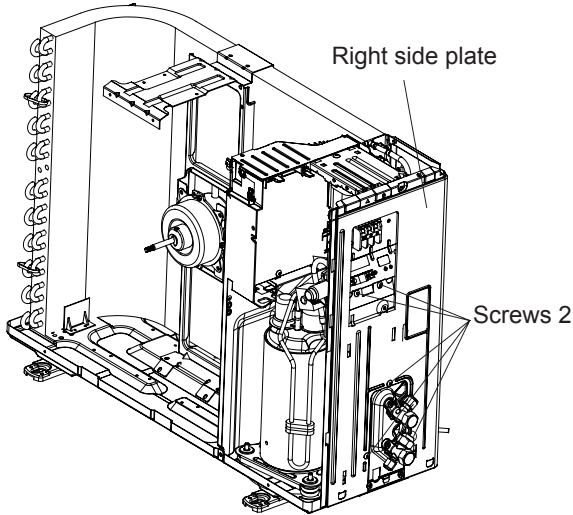
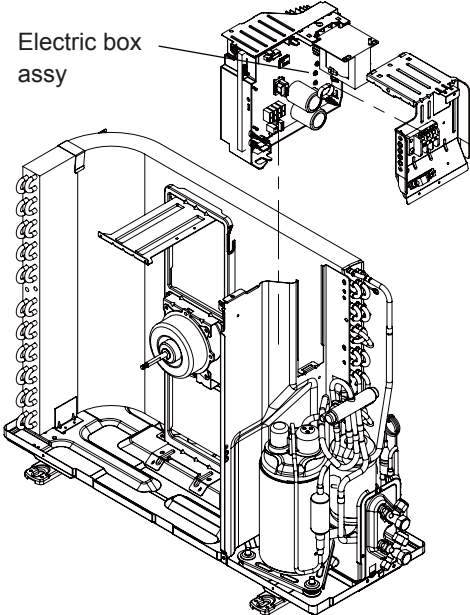
Step	Procedure
<p data-bbox="120 220 618 248">6. Remove protective grille and right side plate</p>	<div data-bbox="224 373 680 467" style="margin-bottom: 20px;"> <p>Remove the screws 1 fixing protective grille and then remove the protective grille.</p> </div> <div data-bbox="224 899 680 963" style="margin-bottom: 20px;"> <p>Remove the screws 2 fixing right side plate and then remove the right side plate.</p> </div> <div data-bbox="776 235 1481 716" style="text-align: right;">  </div> <div data-bbox="868 794 1442 1306" style="text-align: right;">  </div>
<p data-bbox="120 1356 423 1384">7. Remove electric box assy</p>	<div data-bbox="224 1472 680 1565" style="margin-bottom: 20px;"> <p>Remove the screws fixing electric box assy ; pull out each wiring terminal; lift the electric box assy upwards to remove it.</p> </div> <div data-bbox="224 1600 667 1723" style="margin-bottom: 20px;"> <p>Note: When pulling out the wiring terminal, pay attention to loose the clasp and dont pull it so hard.</p> </div> <div data-bbox="846 1393 1317 2004" style="text-align: right;">  </div>

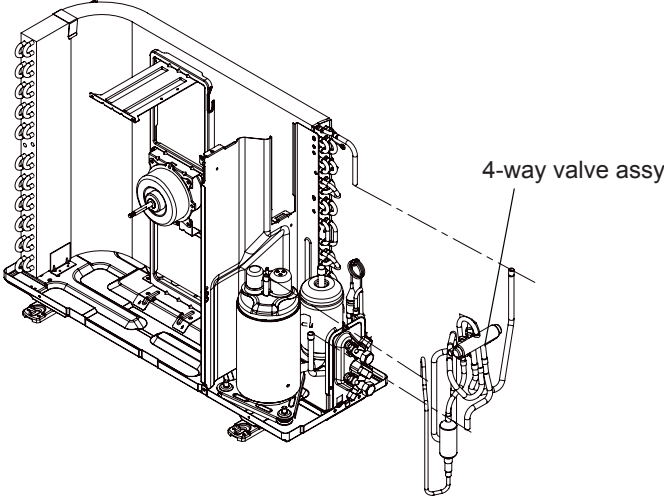
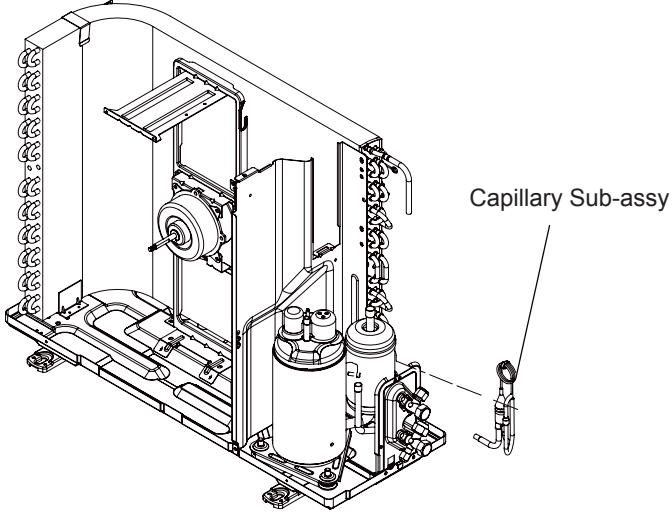
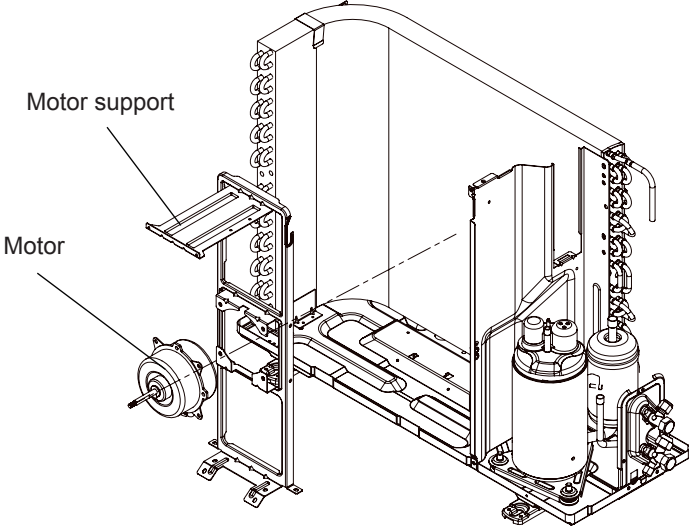
Step	Procedure
8. Remove 4-way valve assy	<p>Unsolder the spot weld of 4-way valve assy, compressor and condenser, and then remove the 4-way valve assy .</p> <p>Note: When unsoldering the spot weld, wrap the 4-way valve with wet cloth completely to avoid damaging the valve due to high temperature.</p> 
9. Remove capillary sub-assy	<p>Unsolder weld point of capillary Sub-assy, valve and outlet pipe of condensator. Then remove the capillary Sub-assy. Do not block the capillary when unsoldering it. (Note: before unsoldering, discharge refrigerants completely)</p> 
10. Remove motor and motor support	<p>Remove the 4 tapping screws fixing the motor. Pull out the lead-out wire and remove the motor. Remove the 2 tapping screws fixing the motor support. Lift motor support to re-move it.</p> 

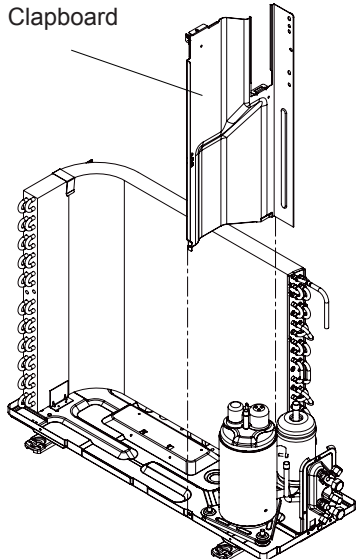
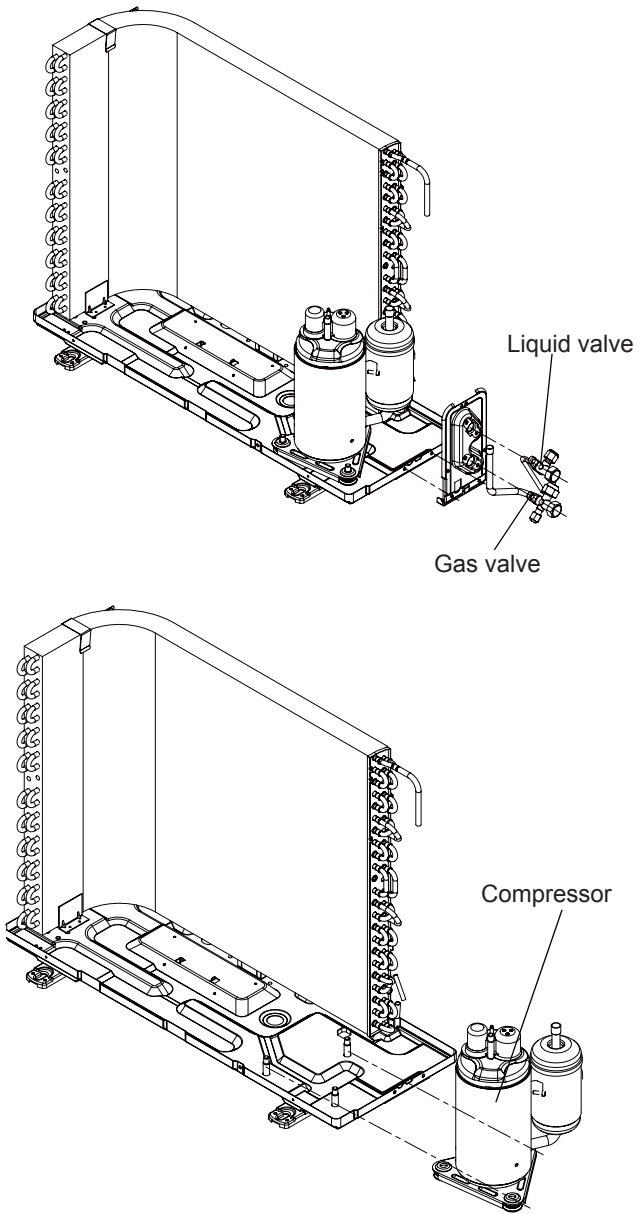
Step	Procedure
11. Remove clapboard sub-assy	<p>Loosen the screws of the Clapboard Sub-Assy . The Clapboard Sub-Assy has a hook on the lower side. Lift and pull the Clapboard Sub-Assy to remove.</p> 
12. Remove Compressor	<p>Remove the 2 screws fixing the gas valve. Unsolder the welding spot connecting gas valve and air return pipe and remove the gas valve. (Note: it is necessary to warp the gas valve when unsoldering the welding spot.) Remove the 2 screws fixing liquid valve. Unsolder the welding spot connecting liquid valve and remove the liquid valve.</p> <p>Remove the 3 footing screws of the compressor and remove the compressor.</p> 

GWH09YC-K6DNA1A/O 12K

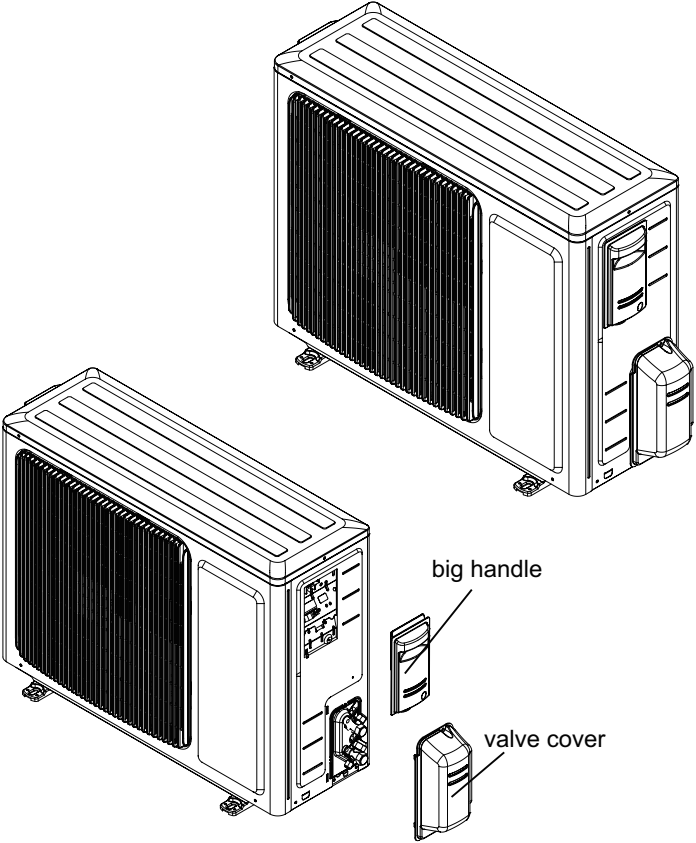
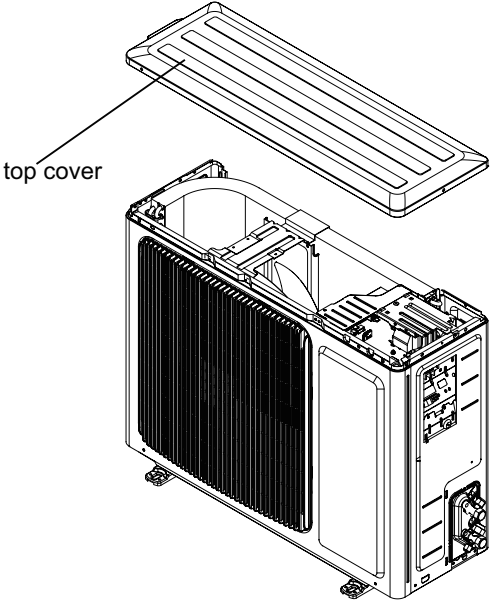
Steps	Procedure
<p>1.Remove big handle</p>	<p>Before disassamble.</p> <p>Remove the screws fixing big handle、 valve cover and then remove them.</p> 
<p>2. Remove top cover</p>	<p>Remove the screws fixing top panel and then remove the top panel.</p> 

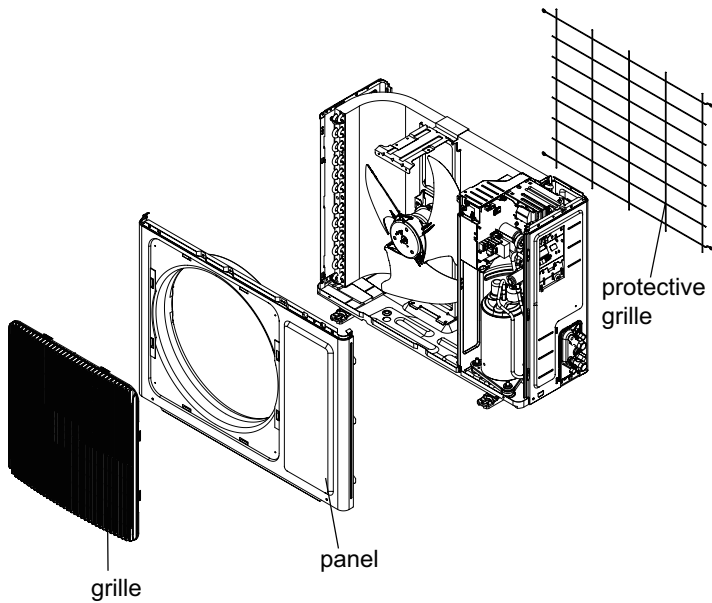
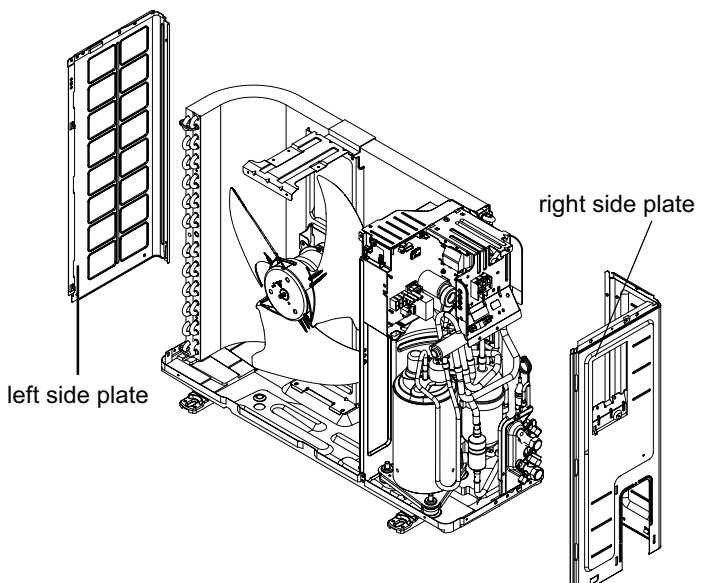
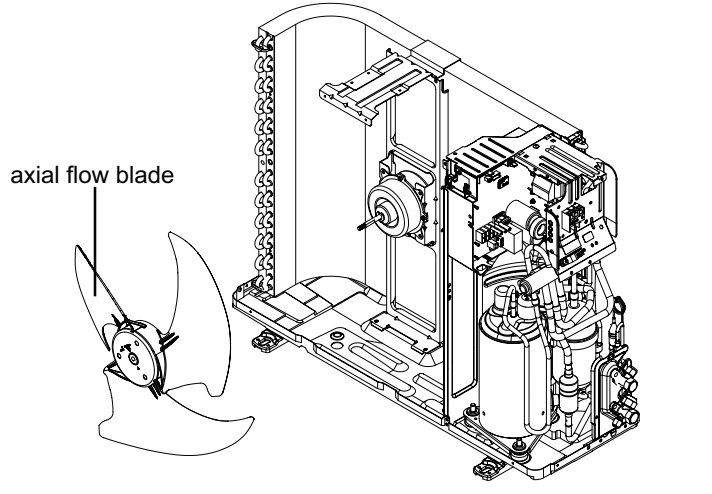
Step	Procedure
<p>3.Remove grille 、 protective grille and front panel</p>	<p>Remove connection screws between the front grille and the front panel. Then remove the front grille. Remove connection screws connecting the front panel with the chassis and the motor support, and then remove the front panel. Remove the screws fixing protective grille and then remove the protective grille.</p> 
<p>4.Remove right side plate、 left side plate</p>	<p>Remove the screws fixing right side plate、 left side plate and then remove them.</p> 
<p>5.Remove axial flow blade</p>	<p>Remove the nut fixing the blade and then remove the axial flow blade.</p> 

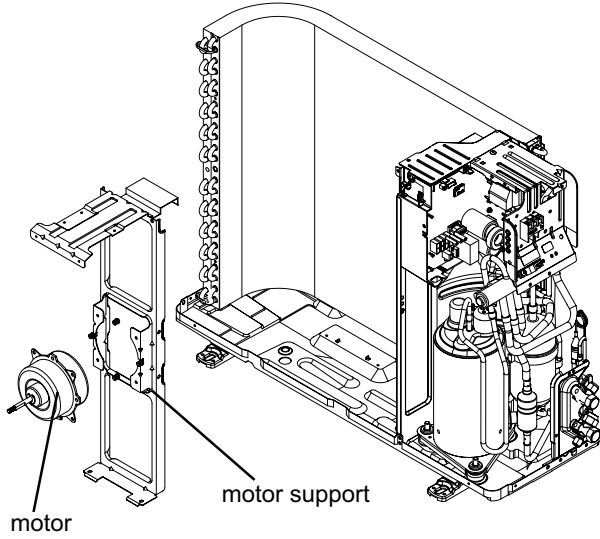
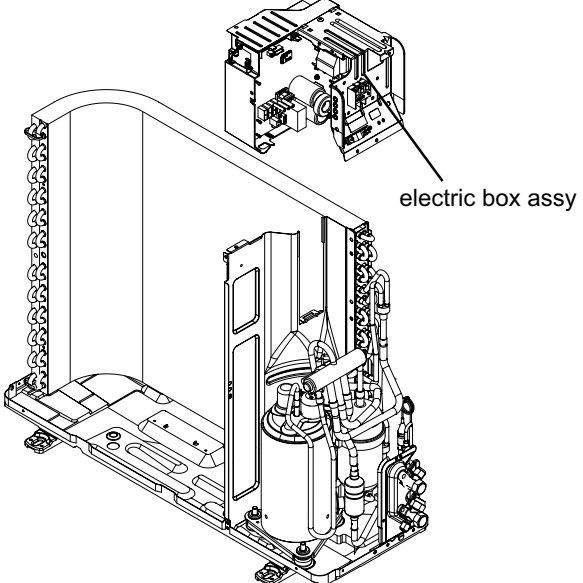
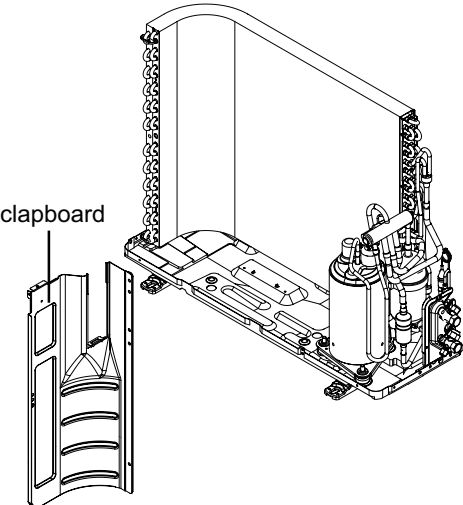
Step	Procedure
<p>6.Remove motor and motor support</p>	<p>Remove the screws fixing motor and then remove the motor. Remove the screws fixing motor support and then remove the motor support.</p>  <p>motor</p> <p>motor support</p>
<p>7.Remove electric box assy</p>	<p>Remove the screws fixing electric box assy; cut off the tieline; pull out each wiring terminal; lift the electric box assy upwards to remove it. Note: When pulling out the wiring terminal, pay attention to loose the clasp and don't pull it so hard.</p>  <p>electric box assy</p>
<p>8.Remove clapboard</p>	<p>Remove the screws fixing clapboard and then remove the clapboard.</p>  <p>clapboard</p>

Step	Procedure
<p>9.Remove 4-way valve assy and capillary sub-assy</p>	<p>Unsolder the welding joints connecting the 4-way valve assy with capillary sub-assy, compressor and condenser; remove the 4-way valve.</p> <p>Note: Before unsoldering the welding joint, wrap the 4-way valve with a wet cloth completely to avoid damage to the valve caused by high temperature.</p> <p>Unsolder weld point of capillary Sub-assy, valve and outlet pipe of condensor. Then remove the capillary Sub-assy. Do not block the capillary when unsoldering it. (Note: before unsoldering, discharge refrigerants completely)</p>
<p>10.Remove liquid valve and gas valve</p>	<p>Unsolder the welding joint connecting the valve with capillary and condenser; unsolder the welding joint connecting the gas valve and air-return pipe; remove the 2 screws fixing the gas valve to remove the gas valve.</p> <p>Unsolder the welding joint connecting the liquid valve and Y-shaped pipe; remove the 2 screws fixing the liquid valve to remove the liquid valve.</p> <p>Note: Before unsoldering the welding joint, wrap the gas valve with a wet cloth completely to avoid damage to the valve caused by high temperature.</p>
<p>11.Remove compressor</p>	<p>Remove the 3 footing screws of the compressor and remove the compressor.</p> <p>Remove the screws fixing valve support and then remove the valve support.</p>

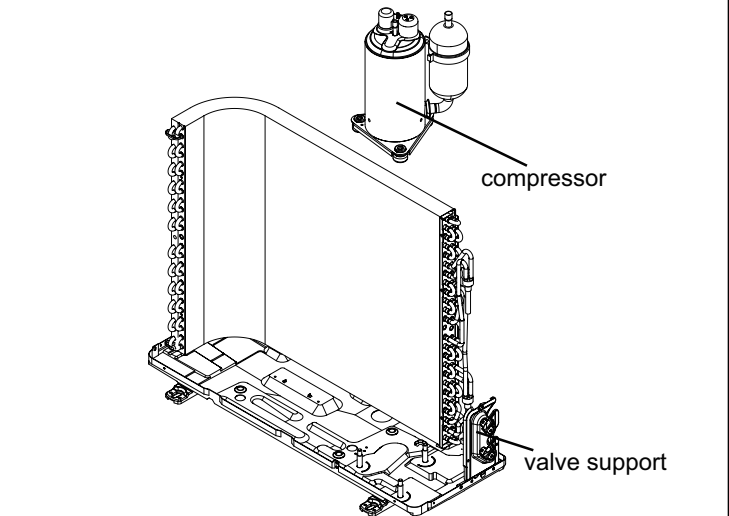
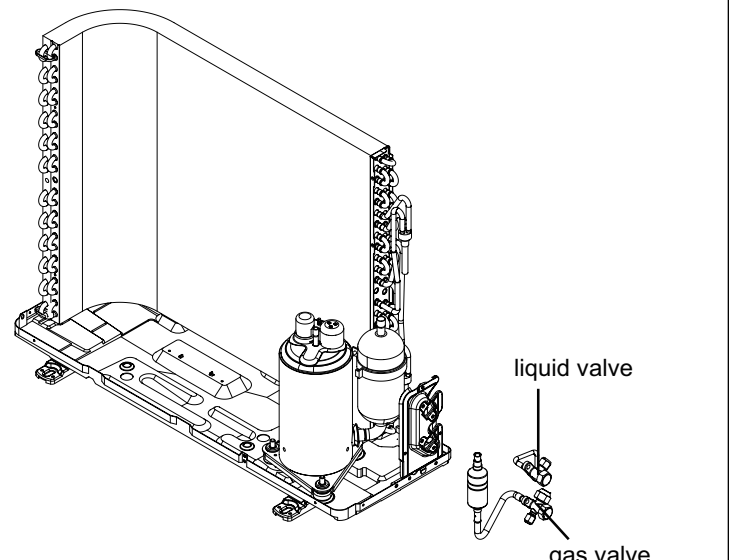
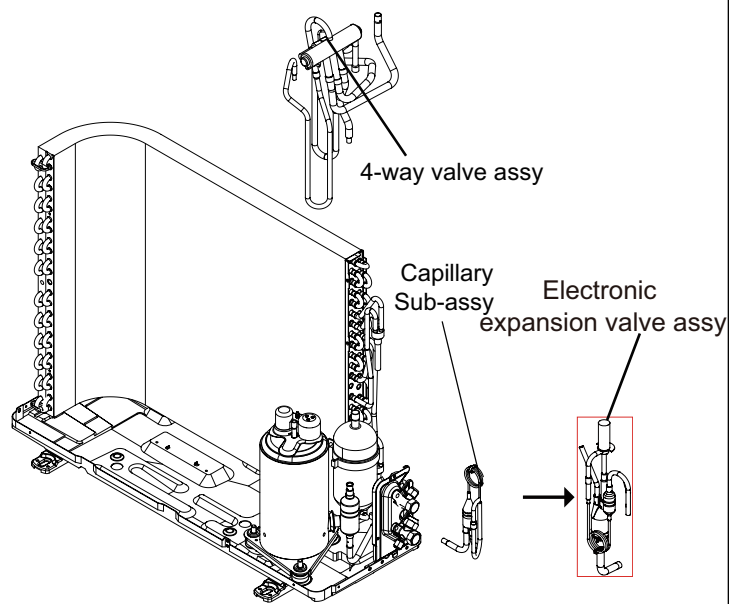

18/24K

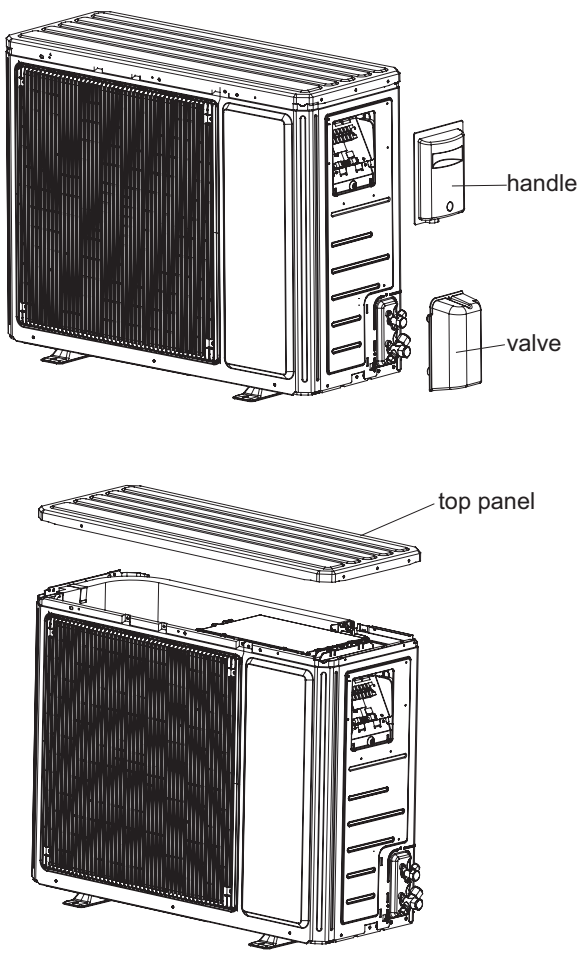
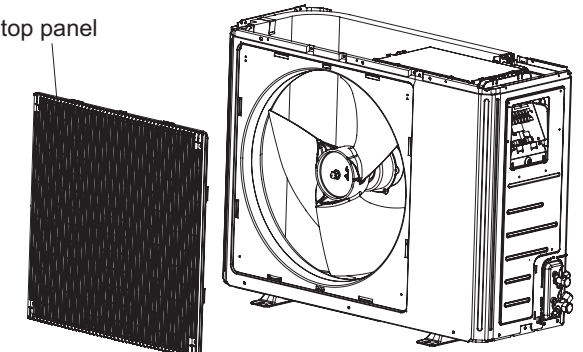
Steps	Procedure	
<p>1. Remove top panel</p> <p>a Twist off the screws used for fixing the handle and valve cover, pull the handle and valve cover upward to remove it.</p> <p>b Remove the 3 screws connecting the top panel with the front panel and the right side plate, and then remove the top panel.</p>	 <p>Diagram illustrating the removal of the top panel. The top panel is shown being lifted off the front panel and the right side plate. Labels include 'handle', 'valve', and 'top panel'.</p>	
<p>2. Remove grille , panel and rear grill</p> <p>a Remove the 2 screws connecting the grille and the panel, and then remove the grille.</p>	 <p>Diagram illustrating the removal of the grille. The grille is shown being lifted off the front panel, revealing the fan behind it. Label includes 'top panel'.</p>	

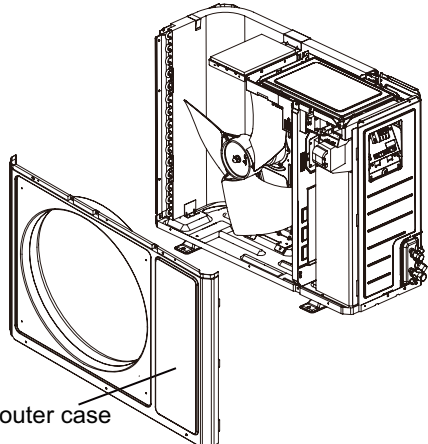
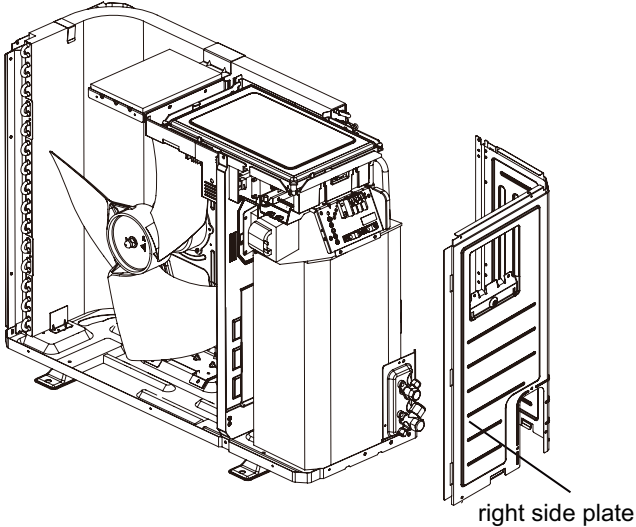
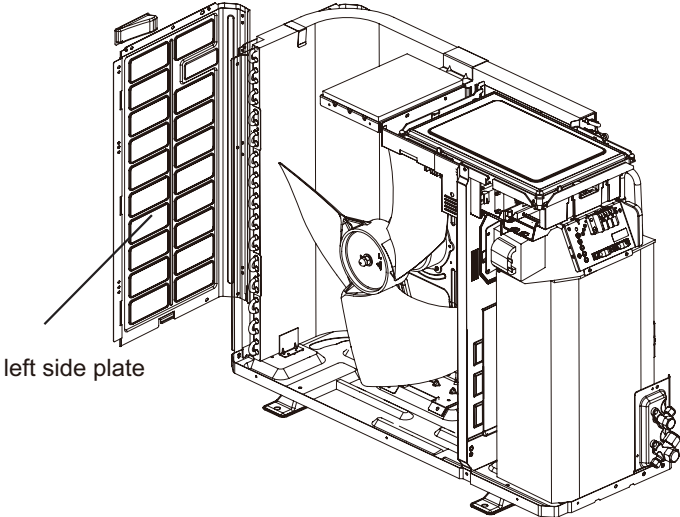
Steps	Procedure	
b	<p>Remove the screws connecting the outer case with motor support, isolation plate and chassis; lift the outer case upwards; loosen the clasps of outer case with right side plate and left side plate, and then remove the outer case.</p>	 <p>outer case</p>
3. Remove right&left side plate		
a	<p>Remove the screws connecting the right side plate with electric box assy, valve support, chassis and condenser side plate, and then remove the right side plate.</p>	 <p>right side plate</p>
b	<p>Remove the screws connecting the left side plate with chassis, and then remove the left side plate.</p>	 <p>left side plate</p>

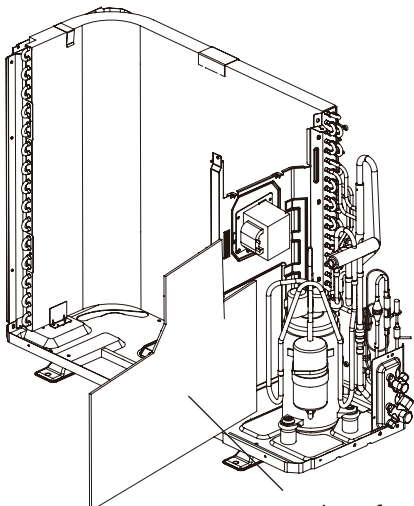
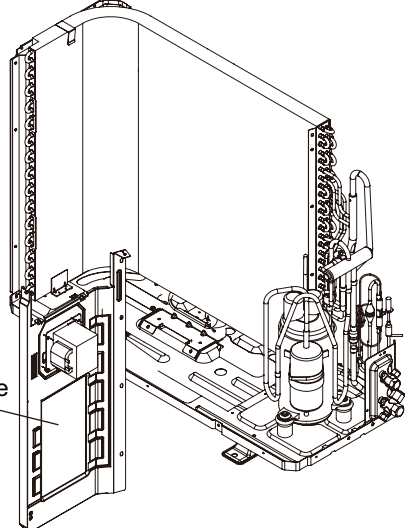
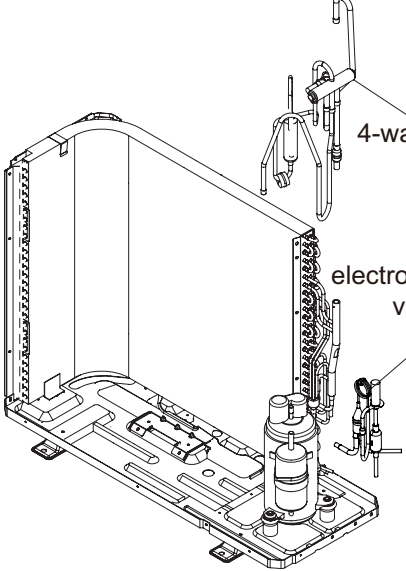
Steps	Procedure	
6. Remove the soundproof sponge	Tear off the sticking stripe and then remove the soundproof sponge.	 <p style="text-align: right;">soundproof sponge</p>
7. Remove isolation plate	Remove the 2 screws connecting the isolation plate and condenser side plate; remove the 3 screws connecting the isolation plate and chassis, and then remove the isolation plate.	 <p style="text-align: left;">isolation plate</p>
8. Remove 4-way valve assy and electronic expansion valve assy	<p>Unsolder the welding joints connecting electronic expansion valve assy the 4-way valve assy with capillary sub-assy, compressor and condenser; remove the electronic expansion valve assy and 4-way valve.</p> <p>Note: Before unsoldering the welding joint, wrap the 4-way valve with a wet cloth completely to avoid damage to the valve caused by high temperature.</p>	 <p style="text-align: right;">4-way valve assy</p> <p style="text-align: right;">electronic expansion valve assy</p>

GWH09AGA-K6DNA1A/O GWH12AGB-K6DNA1A/O

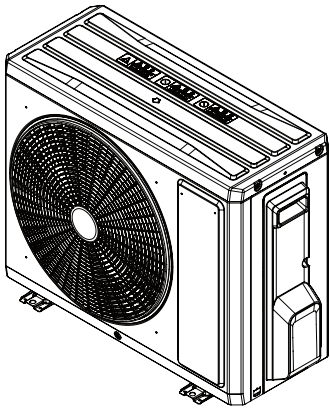
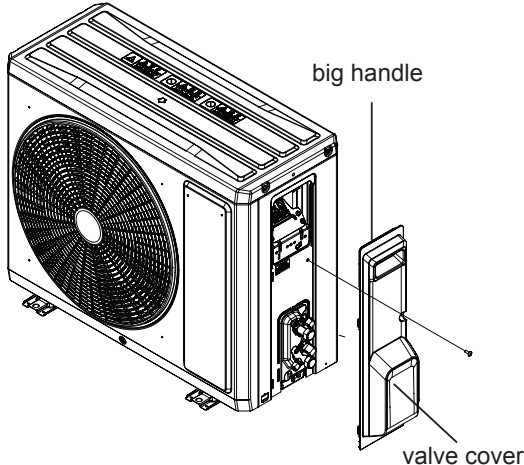
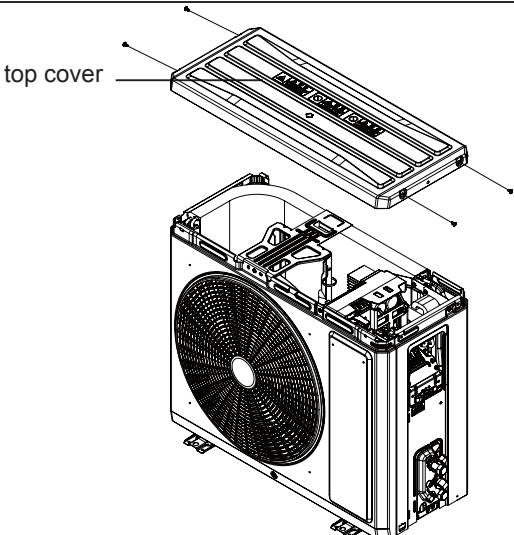
Steps	Procedure
<p>1. Before disassembly</p>	
<p>2. Remove big handle and valve cover</p>	<p>Remove the connection screw fixing the big handle and then remove the valve cover.</p> 
<p>3. Remove top cover</p>	<p>Remove connection screws connecting the top panel with the front panel and the right side plate, and then remove the top panel.</p> 

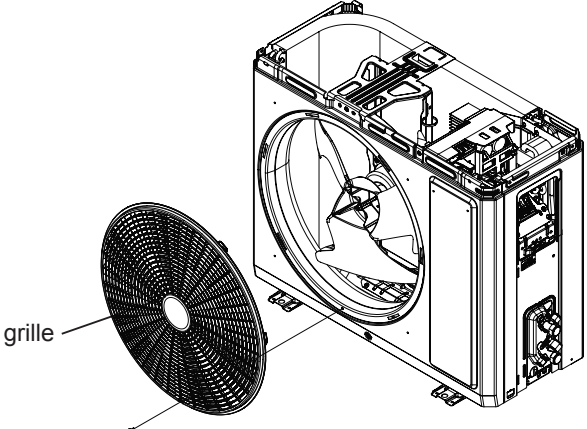
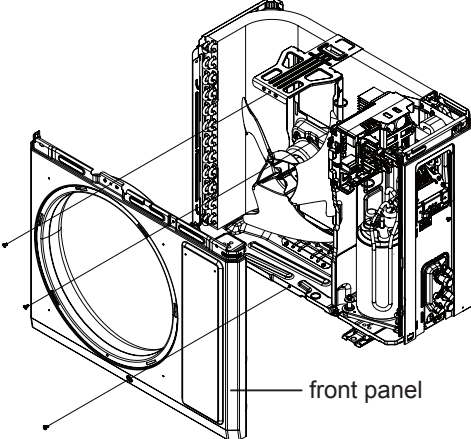
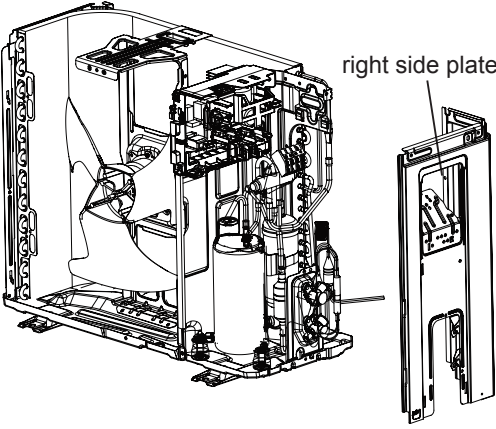
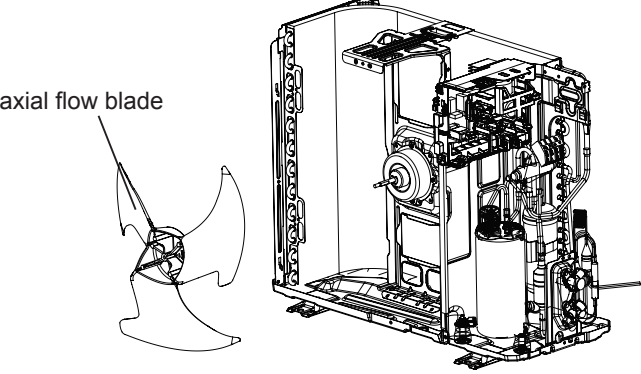
Steps	Procedure
<p>4. Remove grille</p>	<p>Remove connection screws between the front grille and the front panel. Then remove the grille.</p> 
<p>5. Remove front panel</p>	<p>Remove connection screws connecting the front panel with the chassis and the motor support and then remove the front panel.</p> 
<p>6. Remove right side plate</p>	<p>Remove connection screws connecting the right side plate with the valve support and the electric box. Then remove the right side plate.</p> 
<p>7. Remove axial flow blade</p>	<p>Remove the nut on the blade and then remove the axial flow blade.</p> 

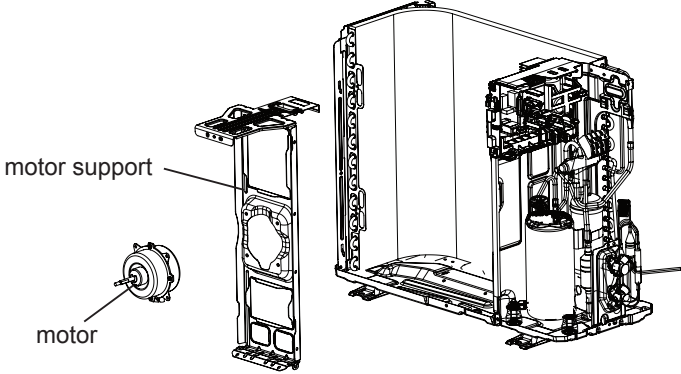
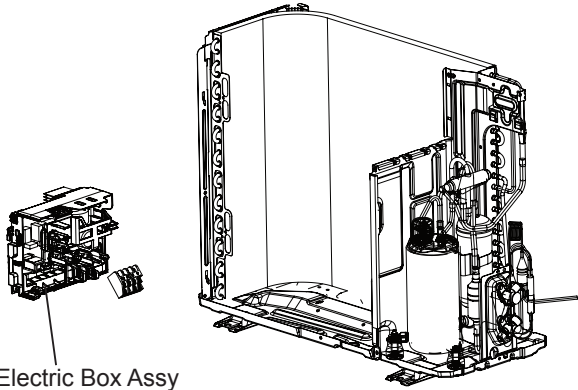
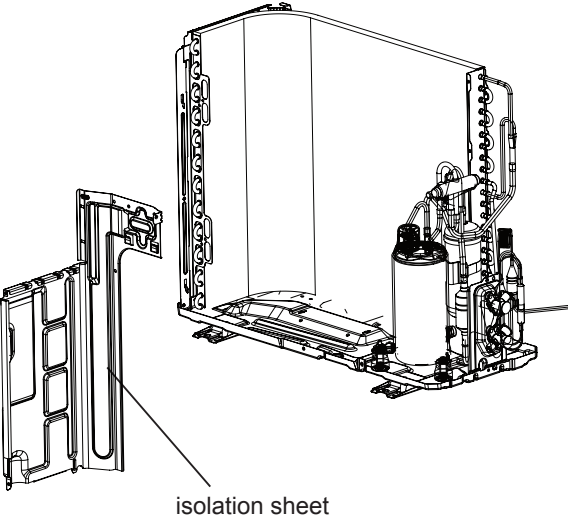
Steps	Procedure
8. Remove motor and motor support	<p>Remove the tapping screws fixing the motor and disconnect the leading wire insert of the motor. Then remove the motor. Remove the tapping screws fixing the motor support and lift the motor support to remove it.</p>  <p>motor support</p> <p>motor</p>
9. Remove Electric Box Assy	<p>Remove screws fixing the electric box subassembly; loosen the wire bundle and unplug the wiring terminals. Then lift the electric box to remove it.</p>  <p>Electric Box Assy</p>
10. Remove isolation sheet	<p>Remove the screws fixing the isolation sheet and then remove the isolation sheet.</p>  <p>isolation sheet</p>

Steps	Procedure
<p>11. Remove compressor</p>	
<p>a</p>	<p>Unsolder the welding joint connecting the capillary, valves and the outlet pipe of condenser to remove the capillary. Do not block the capillary with welding slag during unsoldering.</p>
<p>b</p>	<p>Remove the 2 screws fixing the gas valve and unsolder the welding joint between the gas valve and the air-return pipe to remove the gas valve. (NOTE: Discharge the refrigerant completely before unsoldering; when unsoldering, wrap the gas valve with a wet cloth completely to avoid damage to the valve caused by high temperature). Remove the 2 screws fixing the liquid valve and unsolder the welding joint connecting the liquid valve to the Y-type pipe to remove the liquid valve.</p>
<p>c</p>	<p>Unsolder pipes connecting with compressor.</p>
<p>d</p>	<p>Remove the 3 foot nuts on the compressor and then remove the compressor.</p>

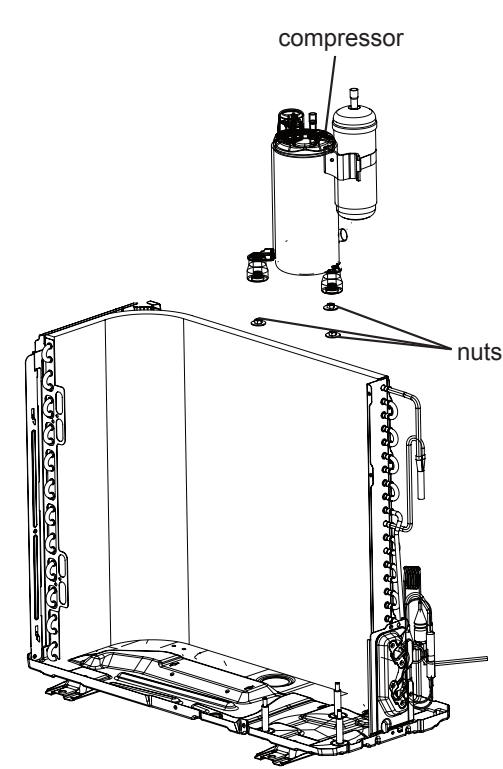
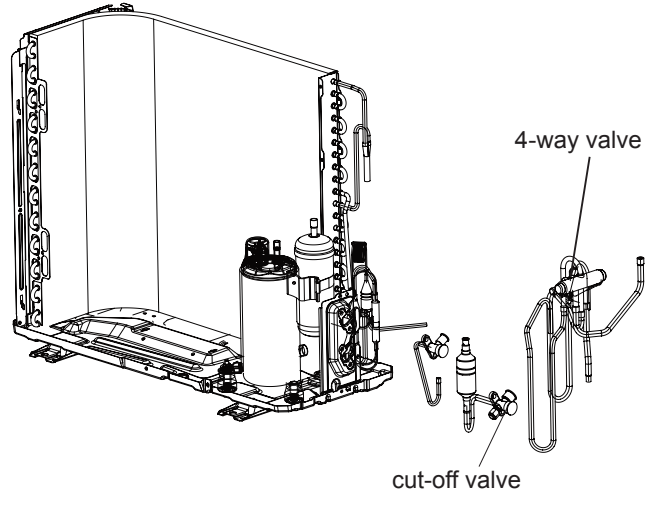

Appendix:

Appendix 1: Reference Sheet of Celsius and Fahrenheit

Conversion formula for Fahrenheit degree and Celsius degree: $T_f = T_c \times 1.8 + 32$

Set temperature

Fahrenheit display temperature (°F)	Fahrenheit (°F)	Celsius (°C)	Fahrenheit display temperature (°F)	Fahrenheit (°F)	Celsius (°C)	Fahrenheit display temperature (°F)	Fahrenheit (°F)	Celsius (°C)
61	60.8	16	69/70	69.8	21	78/79	78.8	26
62/63	62.6	17	71/72	71.6	22	80/81	80.6	27
64/65	64.4	18	73/74	73.4	23	82/83	82.4	28
66/67	66.2	19	75/76	75.2	24	84/85	84.2	29
68	68	20	77	77	25	86	86	30

Ambient temperature

Fahrenheit display temperature (°F)	Fahrenheit (°F)	Celsius (°C)	Fahrenheit display temperature (°F)	Fahrenheit (°F)	Celsius (°C)	Fahrenheit display temperature (°F)	Fahrenheit (°F)	Celsius (°C)
32/33	32	0	55/56	55.4	13	79/80	78.8	26
34/35	33.8	1	57/58	57.2	14	81	80.6	27
36	35.6	2	59/60	59	15	82/83	82.4	28
37/38	37.4	3	61/62	60.8	16	84/85	84.2	29
39/40	39.2	4	63	62.6	17	86/87	86	30
41/42	41	5	64/65	64.4	18	88/89	87.8	31
43/44	42.8	6	66/67	66.2	19	90	89.6	32
45	44.6	7	68/69	68	20	91/92	91.4	33
46/47	46.4	8	70/71	69.8	21	93/94	93.2	34
48/49	48.2	9	72	71.6	22	95/96	95	35
50/51	50	10	73/74	73.4	23	97/98	96.8	36
52/53	51.8	11	75/76	75.2	24	99	98.6	37
54	53.6	12	77/78	77	25			

Appendix 2: Configuration of Connection Pipe

- Standard length of connection pipe. (More details please refer to the specifications)
- Min length of connection pipe For the unit with standard connection pipe of 5m, there is no limitation for them in length of connection pipe. For the unit with standard connection pipe of 7.5m and 8m, the min length of connection pipe is 3m.
- Max length of connection pipe (More details please refer to the specifications)
- The additional refrigerant oil and refrigerant charging required after prolonging connection pipe
 - After the length of connection pipe is prolonged for 10m at the basis of standard length, you should add 5ml of refrigerant oil for each additional 5m of connection pipe.
 - The calculation method of additional refrigerant charging amount (on the basis of liquid pipe):
 - Basing on the length of standard pipe, add refrigerant according to the requirement as shown in the table. The additional refrigerant charging amount per meter is different according to the diameter of liquid pipe. See Sheet 2.
 - Additional refrigerant charging amount = prolonged length of liquid pipe X additional refrigerant charging amount per meter

Additional refrigerant charging amount for R32				
Diameter of connection pipe		Indoor unit throttl	Outdoor unit throttle	
Liquid pipe	Gas pipe	Cooling only, cooling and heating(g / m)	Cooling only(g / m)	Cooling and heating(g / m)
Φ1/4"	Φ3/8" or Φ1/2"	16	12	16
Φ1/4" or Φ3/8"	Φ5/8" or Φ3/4"	40	12	40
Φ1/2"	Φ3/4" or Φ7/8"	80	24	96
Φ5/8"	Φ1" or Φ1 1/4"	136	48	96
Φ3/4"	/	200	200	200
Φ7/8"	/	280	280	280

Note: The additional refrigerant charging amount in Sheet 2 is recommended value, not compulsory.

Appendix 3: Pipe Expanding Method

⚠ Note:

Improper pipe expanding is the main cause of refrigerant leakage. Please expand the pipe according to the following steps:

A: Cut the pipe

- Confirm the pipe length according to the distance of indoor unit and outdoor unit.
- Cut the required pipe with pipe cutter.

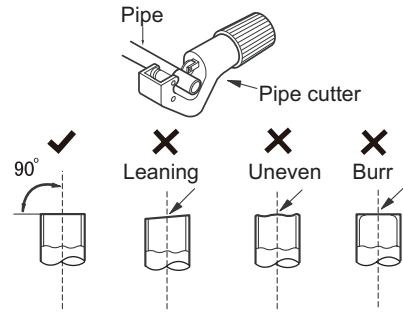

B: Remove the burrs

- Remove the burrs with shaper and prevent the burrs from getting into the pipe.

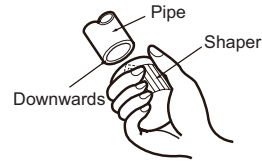

C: Put on suitable insulating pipe

D: Put on the union nut

- Remove the union nut on the indoor connection pipe and outdoor valve; install the union nut on the pipe.

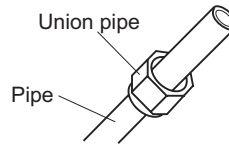

E: Expand the port

- Expand the port with expander.

⚠ Note:

- "A" is different according to the diameter, please refer to the sheet below:

Outer diameter(mm)	A(mm)	
	Max	Min
Φ6 - 6.35 (1/4")	1.3	0.7
Φ9 - Φ9.52 (3/8")	1.6	1.0
Φ12 - 12.70 (1/2")	1.8	1.0
Φ16 - 15.88 (5/8")	2.4	2.2

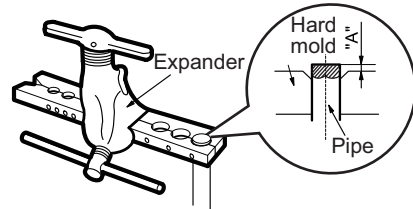

F: Inspection

- Check the quality of expanding port. If there is any blemish, expand the port again according to the steps above.

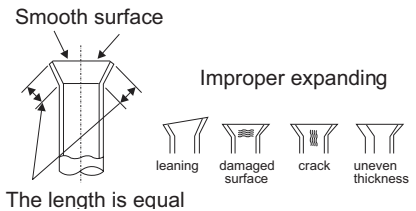

Appendix 4: List of Resistance for Temperature Sensor

Resistance Table of Ambient Temperature Sensor for Indoor and Outdoor (15K)

Temp(°C)	Resistance(kΩ)	Temp(°C)	Resistance(kΩ)	Temp(°C)	Resistance(kΩ)	Temp(°C)	Resistance(kΩ)
-19	138.1	20	18.75	59	3.848	98	1.071
-18	128.6	21	17.93	60	3.711	99	1.039
-17	121.6	22	17.14	61	3.579	100	1.009
-16	115	23	16.39	62	3.454	101	0.98
-15	108.7	24	15.68	63	3.333	102	0.952
-14	102.9	25	15	64	3.217	103	0.925
-13	97.4	26	14.36	65	3.105	104	0.898
-12	92.22	27	13.74	66	2.998	105	0.873
-11	87.35	28	13.16	67	2.896	106	0.848
-10	82.75	29	12.6	68	2.797	107	0.825
-9	78.43	30	12.07	69	2.702	108	0.802
-8	74.35	31	11.57	70	2.611	109	0.779
-7	70.5	32	11.09	71	2.523	110	0.758
-6	66.88	33	10.63	72	2.439	111	0.737
-5	63.46	34	10.2	73	2.358	112	0.717
-4	60.23	35	9.779	74	2.28	113	0.697
-3	57.18	36	9.382	75	2.206	114	0.678
-2	54.31	37	9.003	76	2.133	115	0.66
-1	51.59	38	8.642	77	2.064	116	0.642
0	49.02	39	8.297	78	1.997	117	0.625
1	46.6	40	7.967	79	1.933	118	0.608
2	44.31	41	7.653	80	1.871	119	0.592
3	42.14	42	7.352	81	1.811	120	0.577
4	40.09	43	7.065	82	1.754	121	0.561
5	38.15	44	6.791	83	1.699	122	0.547
6	36.32	45	6.529	84	1.645	123	0.532
7	34.58	46	6.278	85	1.594	124	0.519
8	32.94	47	6.038	86	1.544	125	0.505
9	31.38	48	5.809	87	1.497	126	0.492
10	29.9	49	5.589	88	1.451	127	0.48
11	28.51	50	5.379	89	1.408	128	0.467
12	27.18	51	5.197	90	1.363	129	0.456
13	25.92	52	4.986	91	1.322	130	0.444
14	24.73	53	4.802	92	1.282	131	0.433
15	23.6	54	4.625	93	1.244	132	0.422
16	22.53	55	4.456	94	1.207	133	0.412
17	21.51	56	4.294	95	1.171	134	0.401
18	20.54	57	4.139	96	1.136	135	0.391
19	19.63	58	3.99	97	1.103	136	0.382

Resistance Table of Tube Temperature Sensors for Indoor and Outdoor (20K)

Temp(°C)	Resistance(kΩ)	Temp(°C)	Resistance(kΩ)	Temp(°C)	Resistance(kΩ)	Temp(°C)	Resistance(kΩ)
-19	181.4	20	25.01	59	5.13	98	1.427
-18	171.4	21	23.9	60	4.948	99	1.386
-17	162.1	22	22.85	61	4.773	100	1.346
-16	153.3	23	21.85	62	4.605	101	1.307
-15	145	24	20.9	63	4.443	102	1.269
-14	137.2	25	20	64	4.289	103	1.233
-13	129.9	26	19.14	65	4.14	104	1.198
-12	123	27	18.13	66	3.998	105	1.164
-11	116.5	28	17.55	67	3.861	106	1.131
-10	110.3	29	16.8	68	3.729	107	1.099
-9	104.6	30	16.1	69	3.603	108	1.069
-8	99.13	31	15.43	70	3.481	109	1.039
-7	94	32	14.79	71	3.364	110	1.01
-6	89.17	33	14.18	72	3.252	111	0.983
-5	84.61	34	13.59	73	3.144	112	0.956
-4	80.31	35	13.04	74	3.04	113	0.93
-3	76.24	36	12.51	75	2.94	114	0.904
-2	72.41	37	12	76	2.844	115	0.88
-1	68.79	38	11.52	77	2.752	116	0.856
0	65.37	39	11.06	78	2.663	117	0.833
1	62.13	40	10.62	79	2.577	118	0.811
2	59.08	41	10.2	80	2.495	119	0.77
3	56.19	42	9.803	81	2.415	120	0.769
4	53.46	43	9.42	82	2.339	121	0.746
5	50.87	44	9.054	83	2.265	122	0.729
6	48.42	45	8.705	84	2.194	123	0.71
7	46.11	46	8.37	85	2.125	124	0.692
8	43.92	47	8.051	86	2.059	125	0.674
9	41.84	48	7.745	87	1.996	126	0.658
10	39.87	49	7.453	88	1.934	127	0.64
11	38.01	50	7.173	89	1.875	128	0.623
12	36.24	51	6.905	90	1.818	129	0.607
13	34.57	52	6.648	91	1.736	130	0.592
14	32.98	53	6.403	92	1.71	131	0.577
15	31.47	54	6.167	93	1.658	132	0.563
16	30.04	55	5.942	94	1.609	133	0.549
17	28.68	56	5.726	95	1.561	134	0.535
18	27.39	57	5.519	96	1.515	135	0.521
19	26.17	58	5.32	97	1.47	136	0.509

Resistance Table of Discharge Temperature Sensor for Outdoor (50K)

Temp(°C)	Resistance(kΩ)	Temp(°C)	Resistance(kΩ)	Temp(°C)	Resistance(kΩ)	Temp(°C)	Resistance(kΩ)
-29	853.5	10	98	49	18.34	88	4.75
-28	799.8	11	93.42	50	17.65	89	4.61
-27	750	12	89.07	51	16.99	90	4.47
-26	703.8	13	84.95	52	16.36	91	4.33
-25	660.8	14	81.05	53	15.75	92	4.20
-24	620.8	15	77.35	54	15.17	93	4.08
-23	580.6	16	73.83	55	14.62	94	3.96
-22	548.9	17	70.5	56	14.09	95	3.84
-21	516.6	18	67.34	57	13.58	96	3.73
-20	486.5	19	64.33	58	13.09	97	3.62
-19	458.3	20	61.48	59	12.62	98	3.51
-18	432	21	58.77	60	12.17	99	3.41
-17	407.4	22	56.19	61	11.74	100	3.32
-16	384.5	23	53.74	62	11.32	101	3.22
-15	362.9	24	51.41	63	10.93	102	3.13
-14	342.8	25	49.19	64	10.54	103	3.04
-13	323.9	26	47.08	65	10.18	104	2.96
-12	306.2	27	45.07	66	9.83	105	2.87
-11	289.6	28	43.16	67	9.49	106	2.79
-10	274	29	41.34	68	9.17	107	2.72
-9	259.3	30	39.61	69	8.85	108	2.64
-8	245.6	31	37.96	70	8.56	109	2.57
-7	232.6	32	36.38	71	8.27	110	2.50
-6	220.5	33	34.88	72	7.99	111	2.43
-5	209	34	33.45	73	7.73	112	2.37
-4	198.3	35	32.09	74	7.47	113	2.30
-3	199.1	36	30.79	75	7.22	114	2.24
-2	178.5	37	29.54	76	7.00	115	2.18
-1	169.5	38	28.36	77	6.76	116	2.12
0	161	39	27.23	78	6.54	117	2.07
1	153	40	26.15	79	6.33	118	2.02
2	145.4	41	25.11	80	6.13	119	1.96
3	138.3	42	24.13	81	5.93	120	1.91
4	131.5	43	23.19	82	5.75	121	1.86
5	125.1	44	22.29	83	5.57	122	1.82
6	119.1	45	21.43	84	5.39	123	1.77
7	113.4	46	20.6	85	5.22	124	1.73
8	108	47	19.81	86	5.06	125	1.68
9	102.8	48	19.06	87	4.90	126	1.64



JF00303643



GREE ELECTRIC APPLIANCES, INC. OF ZHUHAI

Add: West Jinji Rd, Qianshan, Zhuhai, Guangdong, China, 519070

Tel: (+86-756) 8522219

Fax: (+86-756) 8669426

E-mail: global@cn.gree.com www.gree.com

For product improvement, specifications and appearance in this manual are subject to change without prior notice.