



Service Manual

Models: GWH09UB-K3DNA4F
GWH12UB-K3DNA4F
GWH18UC-K3DNA4F
(Refrigerant R410A)

Table of Contents

Part I : Technical Information	1
1. Summary	1
2. Specifications	2
2.1 Specification Sheet	2
2.2 Operation Characteristic Curve	8
2.3 Capacity Variation Ratio According to Temperature	9
2.4 Cooling and Heating Data Sheet in Rated Frequency	10
2.5 Noise Curve	10
3. Outline Dimension Diagram	11
3.1 Indoor Unit	11
3.2 Outdoor Unit	12
4. Refrigerant System Diagram	13
5. Electrical Part	14
5.1 Wiring Diagram	14
5.2 PCB Printed Diagram	17
6. Function and Control	21
6.1 Remote Controller Introduction	21
6.2 Operation of Smart Control (Smart Phone, Tablet PC)	26
6.3 Brief Description of Modes and Functions	31
Part II : Installation and Maintenance	40
7. Notes for Installation and Maintenance	40
8. Installation	42
8.1 Installation Dimension Diagram	42
8.2 Installation Parts-checking	44
8.3 Selection of Installation Location	44
8.4 Electric Connection Requirement	44
8.5 Installation of Indoor Unit	44
8.6 Installation of Outdoor Unit	47
8.7 Vacuum Pumping and Leak Detection	48
8.8 Check after Installation and Test Operation	48

9. Maintenance	49
9.1 Error Code List	49
9.2 Procedure of Troubleshooting	55
9.3 Troubleshooting for Normal Malfunction.....	79
10. Exploded View and Parts List	81
10.1 Indoor Unit.....	81
10.2 Outdoor Unit.....	86
11. Removal Procedure	90
11.1 Removal Procedure of Indoor Unit	90
11.2 Removal Procedure of Outdoor Unit	99
Appendix:	110
Appendix 1: Reference Sheet of Celsius and Fahrenheit	110
Appendix 2: Configuration of Connection Pipe.....	110
Appendix 3: Pipe Expanding Method	111
Appendix 4: List of Resistance for Temperature Sensor	112

2. Specifications

2.1 Specification Sheet

Parameter	Unit	Value
Model		GWH09UB-K3DNA4F
Product Code		CB264000600 CB264000601
Power Supply	Rated Voltage	V~ 220-240
	Rated Frequency	Hz 50
	Phases	1
Power Supply Mode		Outdoor
Cooling Capacity	W	2600
Heating Capacity	W	3000
Cooling Power Input	W	600
Heating Power Input	W	800
Cooling Power Current	A	2.7
Heating Power Current	A	3.5
Rated Input	W	1630
Rated Current	A	6.5
Air Flow Volume (SH/H/MH/M/ML/L/SL)	m ³ /h	650/530/470/400/350/300/290
Dehumidifying Volume	L/h	0.8
EER	W/W	4.33
COP	W/W	3.75
SEER		7.5
SCOP		4.6
Application Area	m ²	12-18
Indoor Unit	Model	GWH09UB-K3DNA4F/I(Cold Plasma)
	Product Code	CB264N00600 CB264N00601
	Fan Type	Cross-flow
	Diameter Length(DXL)	mm Φ 92X616
	Fan Motor Cooling Speed (SH/H/MH/M/ML/L/SL/Q)	r/min 1350/1127/1000/870/780/690/600/550
	Fan Motor Heating Speed (SH/H/MH/M/ML/L/SL/Q)	r/min 1350/1151/1074/1000/930/870/842/-
	Output of Fan Motor	W 10
	Fan Motor RLA	A 0.3
	Fan Motor Capacitor	μ F /
	Input of Heater	W /
	Evaporator Form	Aluminum Fin-copper Tube
	Pipe Diameter	mm Φ 7
	Row-fin Gap	mm 2-1.5
	Coil Length (LXDXW)	mm 623X25.4X304.8
	Swing Motor Model	MP24HD
	Output of Swing Motor	W 1.5
	Fuse	A 3.15
	Sound Pressure Level (SH/H/MH/M/ML/L/SL)	dB (A) 41/37/35/33/30/22/19
	Sound Power Level (SH/H/MH/M/ML/L/SL)	dB (A) 56/50/48/46/43/35/32
	Dimension (WXHXD)	mm 860X305X170
	Dimension of Carton Box (LXWXH)	mm 932X385X280
Dimension of Package (LXWXH)	mm 935X388X295	
Net Weight	kg 11.5	
Gross Weight	kg 14	

Parameter		Unit	Value
Model			GWH12UB-K3DNA4F
Product Code			CB264000700 CB264000701
Power Supply	Rated Voltage	V~	220-240
	Rated Frequency	Hz	50
	Phases		1
Power Supply Mode			Outdoor
Cooling Capacity		W	3500
Heating Capacity		W	3600
Cooling Power Input		W	920
Heating Power Input		W	970
Cooling Power Current		A	4.1
Heating Power Current		A	4.2
Rated Input		W	1680
Rated Current		A	6.8
Air Flow Volume (SH/H/MH/M/ML/L/SL)		m ³ /h	720/550/490/420/370/320/290
Dehumidifying Volume		L/h	1.4
EER		W/W	3.80
COP		W/W	3.71
SEER			7.0
SCOP			4.6
Application Area		m ²	16-24
Indoor Unit	Model		GWH12UB-K3DNA4F/I(Cold Plasma)
	Product Code		CB264N00700 CB264N00701
	Fan Type		Cross-flow
	Diameter Length(DXL)	mm	Φ92X616
	Fan Motor Cooling Speed (SH/H/MH/M/ML/L/SL/Q)	r/min	1400/1185/1053/920/829/741/650/550
	Fan Motor Heating Speed (SH/H/MH/M/ML/L/SL/Q)	r/min	1400/1185/1119/1053/958/870/842/-
	Output of Fan Motor	W	10
	Fan Motor RLA	A	0.3
	Fan Motor Capacitor	μF	/
	Input of Heater	W	/
	Evaporator Form		Aluminum Fin-copper Tube
	Pipe Diameter	mm	Φ7
	Row-fin Gap	mm	2-1.5
	Coil Length (LXDXW)	mm	623X25.4X304.8
	Swing Motor Model		MP24HD
	Output of Swing Motor	W	1.5
	Fuse	A	3.15
	Sound Pressure Level (SH/H/MH/M/ML/L/SL)	dB (A)	43/38/36/34/31/23/20
	Sound Power Level (SH/H/MH/M/ML/L/SL)	dB (A)	57/51/49/47/44/36/33
	Dimension (WXHXD)	mm	860X305X170
	Dimension of Carton Box (LXWXH)	mm	932X385X280
Dimension of Package (LXWXH)	mm	935X388X295	
Net Weight	kg	11.5	
Gross Weight	kg	14	

Outdoor Unit	Model		GWH12UB-K3DNA4F/O	
	Product Code		CB264W00700	
	Compressor Manufacturer/Trademark		ZHUHAI LANDA COMPRESSOR CO.,LTD.	
	Compressor Model		QXAT-B121zE070	
	Compressor Oil		FV50S	
	Compressor Type		Rotary	
	L.R.A.	A		35
	Compressor RLA	A		6.7
	Compressor Power Input	W		1430
	Overload Protector			1NT11L-6233
	Throttling Method			Electron expansion valve
	Operation temp	°C		16~30
	Ambient temp (cooling)	°C		-18~54
	Ambient temp (heating)	°C		-30~24
	Condenser Form			Aluminum Fin-copper Tube
	Pipe Diameter	mm		Φ7
	Rows-fin Gap	mm		2.5-1.4
	Coil Length (LXDXW)	mm		763X57X550
	Fan Motor Speed	rpm		780
	Output of Fan Motor	W		30
	Fan Motor RLA	A		0.24
	Fan Motor Capacitor	μF		/
	Air Flow Volume of Outdoor Unit	m ³ /h		2400
	Fan Type			Axial-flow
	Fan Diameter	mm		Φ438
	Defrosting Method			Automatic Defrosting
	Climate Type			T1
	Isolation			I
	Moisture Protection			IP24
	Permissible Excessive Operating Pressure for the Discharge Side	MPa		4.3
	Permissible Excessive Operating Pressure for the Suction Side	MPa		2.5
	Sound Pressure Level (H/M/L)	dB (A)		52/-/-
	Sound Power Level (H/M/L)	dB (A)		62/-/-
Dimension (WXHXD)	mm		899X596X378	
Dimension of Carton Box (LXWXH)	mm		945X417X630	
Dimension of Package (LXWXH)	mm		948X420X645	
Net Weight	kg		44.5	
Gross Weight	kg		47.5	
Refrigerant			R410A	
Refrigerant Charge	kg		1.3	
Connection Pipe	Length	m	5	
	Gas Additional Charge	g/m	20	
	Outer Diameter Liquid Pipe	mm	Φ6	
	Outer Diameter Gas Pipe	mm	Φ12	
	Max Distance Height	m	10	
	Max Distance Length	m	20	
Note: The connection pipe applies metric diameter.				

The above data is subject to change without notice; please refer to the nameplate of the unit.

Parameter	Unit	Value	
Model		GWH18UC-K3DNA4F	
Product Code		CB264000500 CB264000501	
Power Supply	Rated Voltage	V~ 220-240	
	Rated Frequency	Hz 50	
	Phases	1	
Power Supply Mode		Outdoor	
Cooling Capacity	W	5275	
Heating Capacity	W	5275	
Cooling Power Input	W	1600	
Heating Power Input	W	1420	
Cooling Power Current	A	7.1	
Heating Power Current	A	6.2	
Rated Input	W	2400	
Rated Current	A	9.1	
Air Flow Volume (SH/H/MH/M/ML/L/SL)	m ³ /h	850/750/650/600/500/400/340	
Dehumidifying Volume	L/h	1.8	
EER	W/W	3.30	
COP	W/W	3.72	
SEER		6.1	
SCOP		4.0	
Application Area	m ²	23-34	
Indoor Unit	Model		GWH18UC-K3DNA4F/I(Cold Plasma)
	Product Code		CB264N00500 CB264N00501
	Fan Type		Cross-flow
	Diameter Length(DXL)	mm	Φ107X699
	Fan Motor Cooling Speed (SH/H/MH/M/ML/L/SL/Q)	r/min	1350/1150/1050/930/800/700/650/600
	Fan Motor Heating Speed (SH/H/MH/M/ML/L/SL/Q)	r/min	1400/1200/1100/1000/900/800/750/-
	Output of Fan Motor	W	20
	Fan Motor RLA	A	0.44
	Fan Motor Capacitor	μF	/
	Input of Heater	W	/
	Evaporator Form		Aluminum Fin-copper Tube
	Pipe Diameter	mm	Φ7
	Row-fin Gap	mm	2-1.5
	Coil Length (LXDXW)	mm	706X25.4X303.8
	Swing Motor Model		MP24AQ
	Output of Swing Motor	W	1.5
	Fuse	A	3.15
	Sound Pressure Level (SH/H/ML/SL)	dB (A)	46/42/40/36/33/25/22
	Sound Power Level (SH/H/M/L/SL)	dB (A)	58/54/52/48/45/37/34
	Dimension (WXHXD)	mm	960X320X205
	Dimension of Carton Box (LXWXH)	mm	1040X400X318
	Dimension of Package (LXWXH)	mm	1043X403X333
	Net Weight	kg	14
Gross Weight	kg	17	

Outdoor Unit	Model		GWH18UC-K3DNA4F/O
	Product Code		CB264W00500
	Compressor Manufacturer/Trademark		ZHUHAI LANDA COMPRESSOR CO.,LTD.
	Compressor Model		QXAT-B121zF070
	Compressor Oil		68EP
	Compressor Type		Rotary
	L.R.A.	A	40
	Compressor RLA	A	6.6
	Compressor Power Input	W	1430
	Overload Protector		1NT11L-6233
	Throttling Method		Electron expansion valve
	Operation temp	°C	16~30
	Ambient temp (cooling)	°C	-18~54
	Ambient temp (heating)	°C	-30~24
	Condenser Form		Aluminum Fin-copper Tube
	Pipe Diameter	mm	Φ7
	Rows-fin Gap	mm	2-1.4
	Coil Length (LXDXW)	mm	852X38.1X660
	Fan Motor Speed	rpm	800
	Output of Fan Motor	W	60
	Fan Motor RLA	A	0.5
	Fan Motor Capacitor	μF	/
	Air Flow Volume of Outdoor Unit	m ³ /h	3200
	Fan Type		Axial-flow
	Fan Diameter	mm	Φ520
	Defrosting Method		Automatic Defrosting
	Climate Type		T1
	Isolation		I
	Moisture Protection		IP24
	Permissible Excessive Operating Pressure for the Discharge Side	MPa	4.3
	Permissible Excessive Operating Pressure for the Suction Side	MPa	2.5
	Sound Pressure Level (H/M/L)	dB (A)	56/-/-
	Sound Power Level (H/M/L)	dB (A)	62/-/-
Dimension (WXHXD)	mm	965X700X396	
Dimension of Carton Box (LXWXH)	mm	1026X455X735	
Dimension of Package (LXWXH)	mm	1029X458X750	
Net Weight	kg	51	
Gross Weight	kg	55.5	
Refrigerant		R410A	
Refrigerant Charge	kg	1.65	
Connection Pipe	Length	m	5
	Gas Additional Charge	g/m	20
	Outer Diameter Liquid Pipe	mm	Φ6
	Outer Diameter Gas Pipe	mm	Φ12
	Max Distance Height	m	10
	Max Distance Length	m	25
	Note: The connection pipe applies metric diameter.		

The above data is subject to change without notice; please refer to the nameplate of the unit.

2.2 Operation Characteristic Curve

09K/12K

Cooling

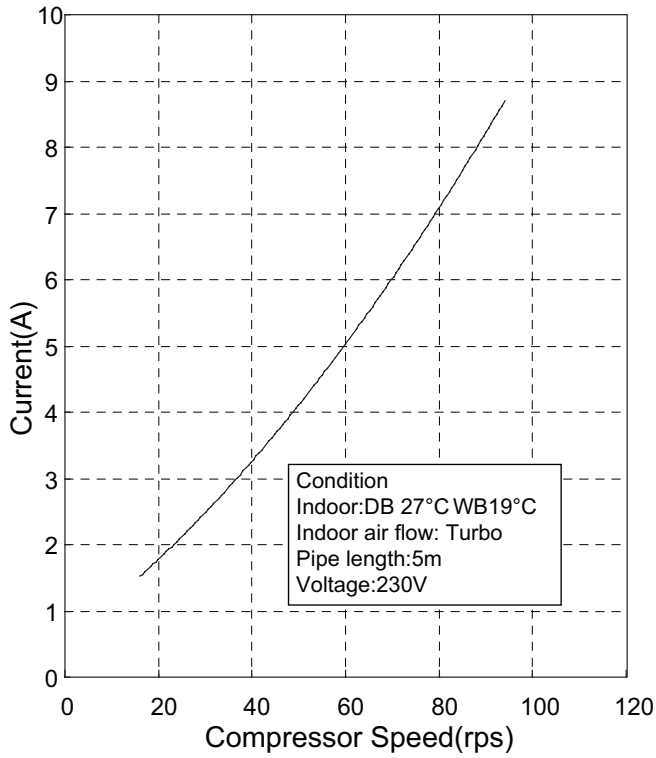

Heating

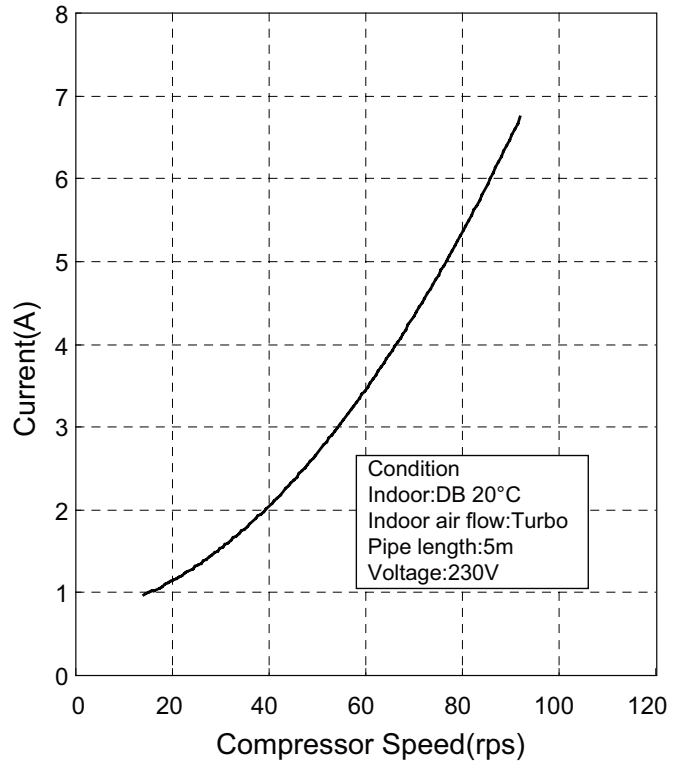

18K

Cooling

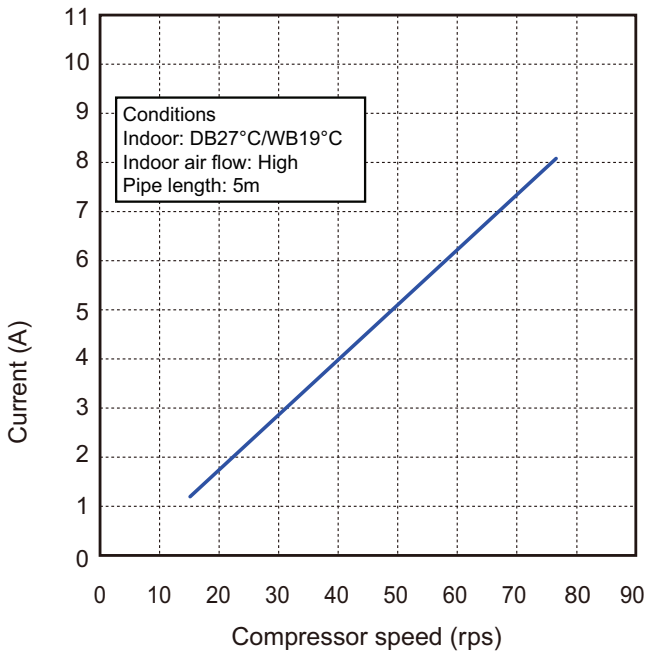

Heating

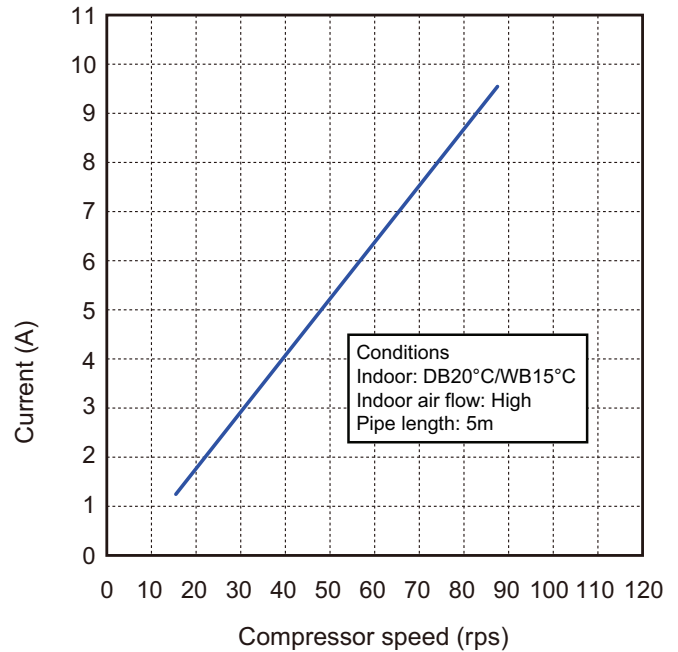

2.3 Capacity Variation Ratio According to Temperature

09K/12K

Cooling

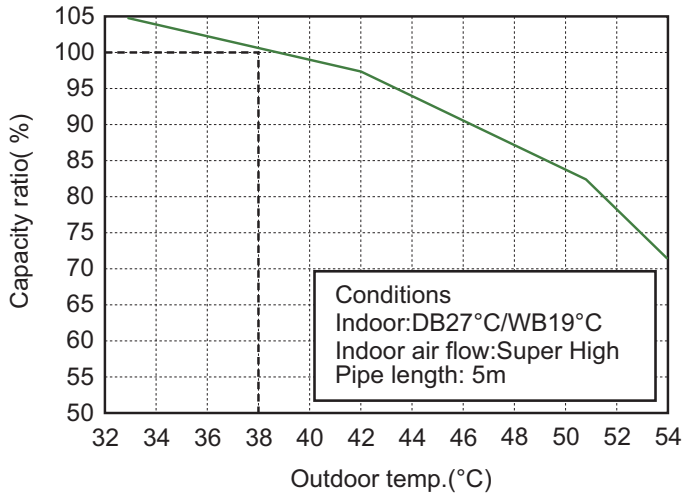

Heating

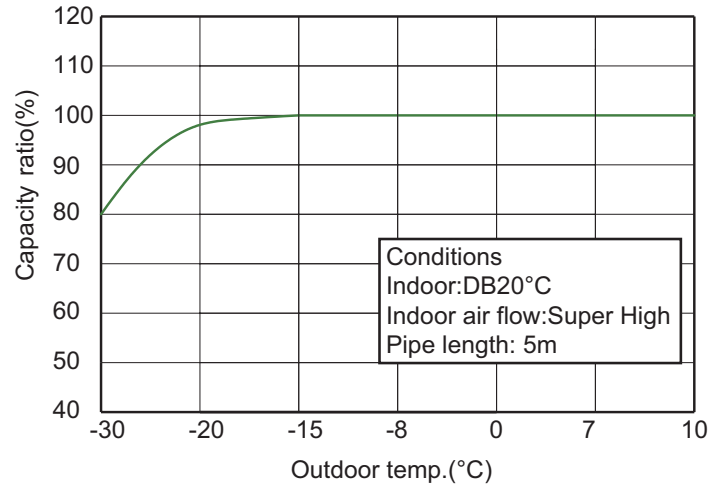

18K

Cooling

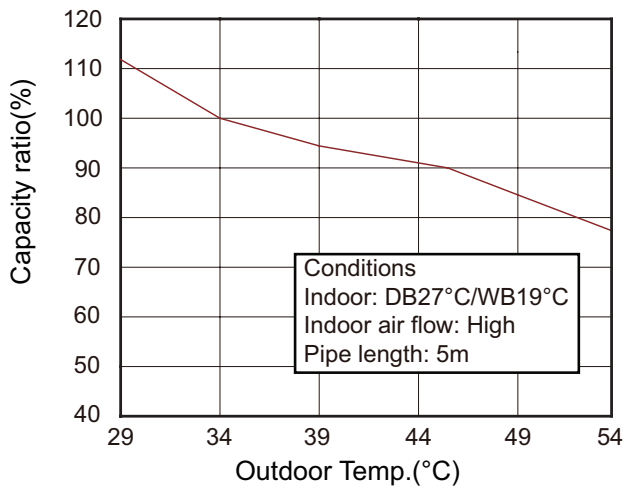

Heating

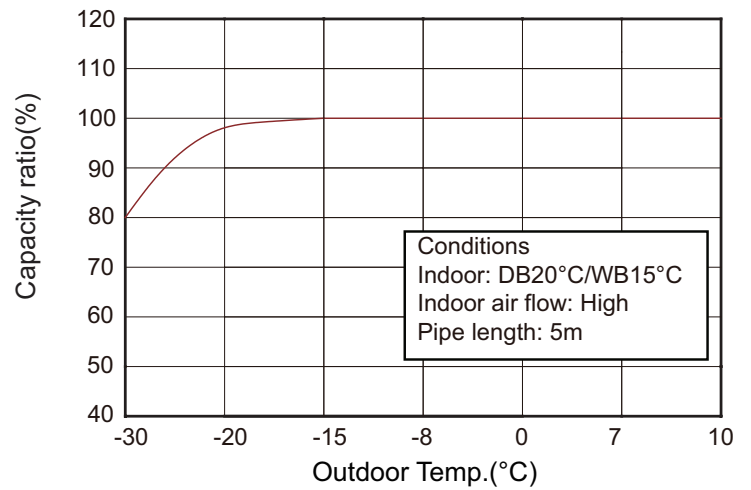

3.2 Outdoor Unit

09K/12K

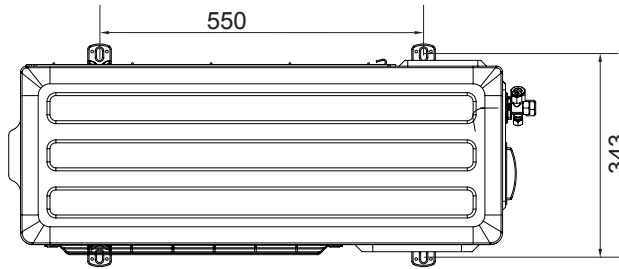
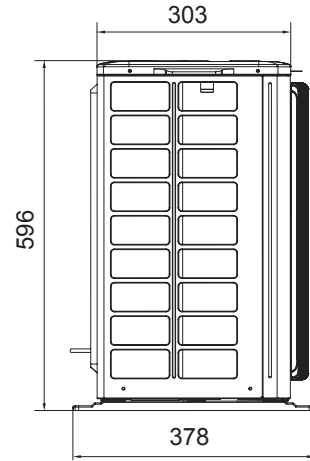
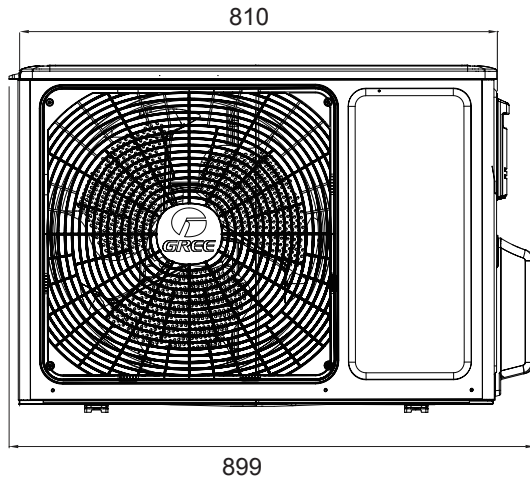

Unit:mm

18K

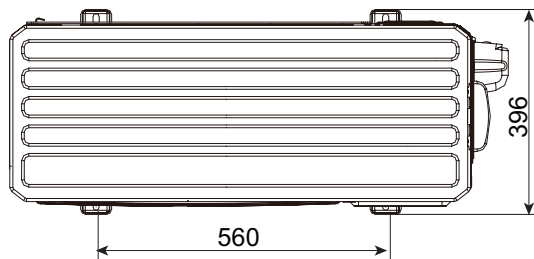
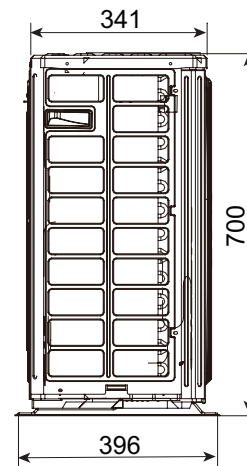
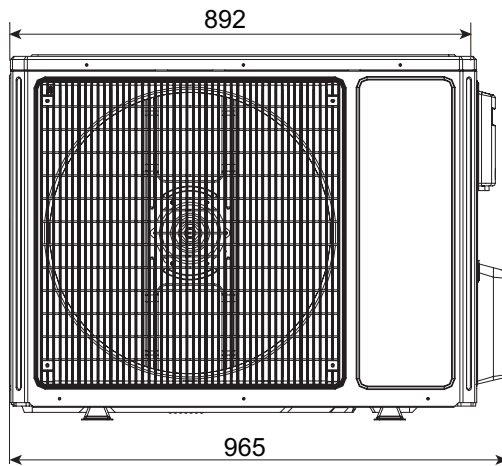

Unit:mm

4. Refrigerant System Diagram

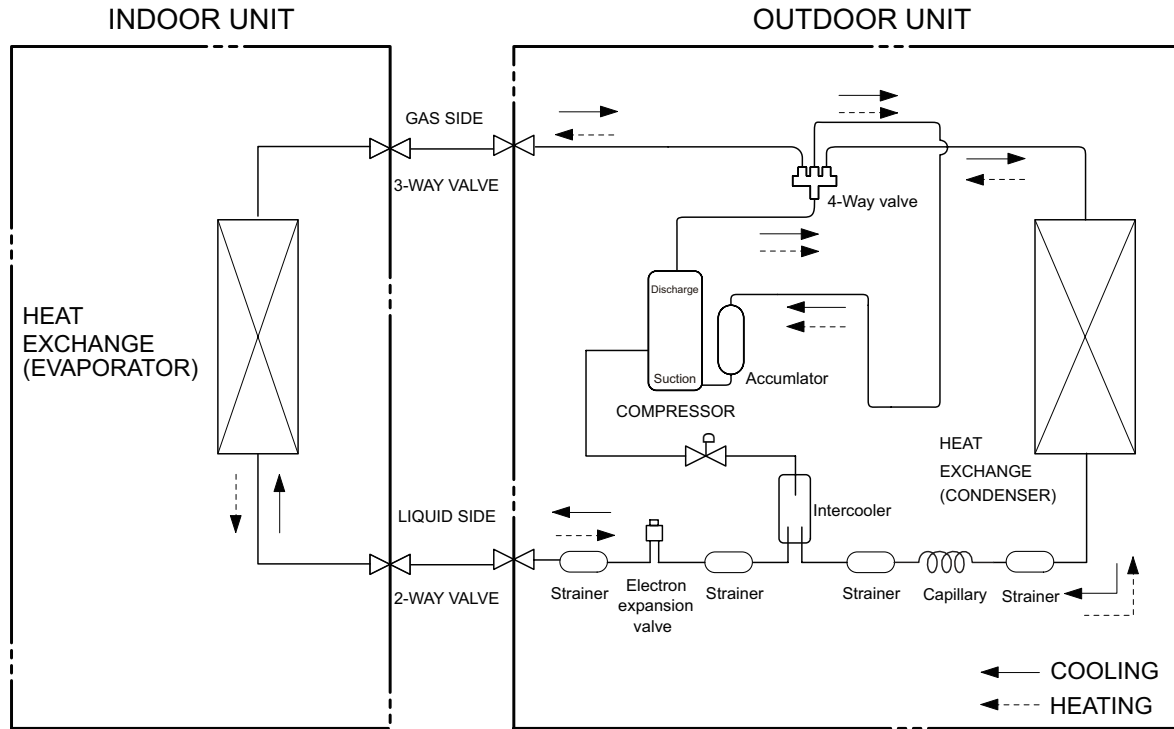

Connection pipe specification:
 Liquid : 1/4" (6mm)
 Gas : 1/2" (16mm)

5. Electrical Part

5.1 Wiring Diagram

● **Instruction**

Symbol	Symbol Color	Symbol	Symbol Color	Symbol	Name
WH	White	GN	Green	CAP	Jumper cap
YE	Yellow	BN	Brown	COMP	Compressor
RD	Red	BU	Blue	⊕	Grounding wire
YEGN	Yellow/Green	BK	Black	/	/
VT	Violet	OG	Orange	/	/

Note: Jumper cap is used to determine fan speed and the swing angle of horizontal lever for this model.

● **Indoor Unit**

GWH09UB-K3DNA4F/I(Cold Plasma), GWH12UB-K3DNA4F/I(Cold Plasma)

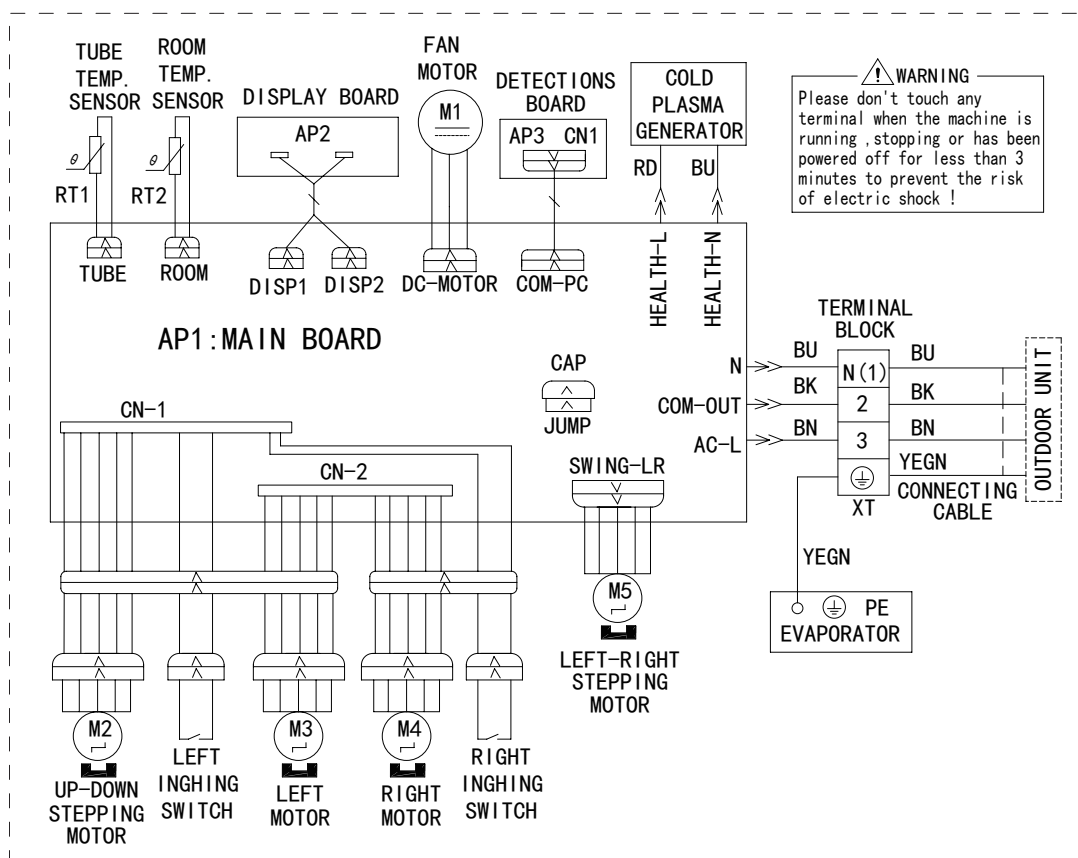

GWH18UC-K3DNA4F/I(Cold Plasma)

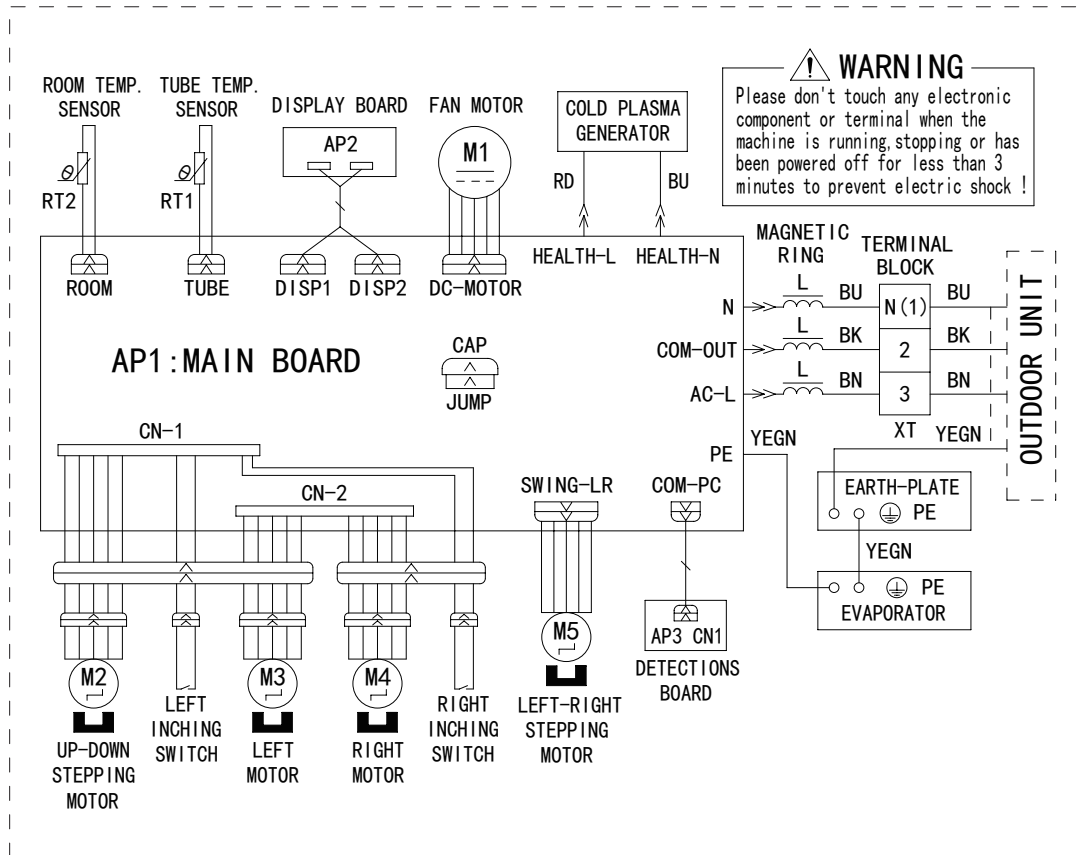

• Outdoor Unit

GWH09UB-K3DNA4F/O, GWH12UB-K3DNA4F/O

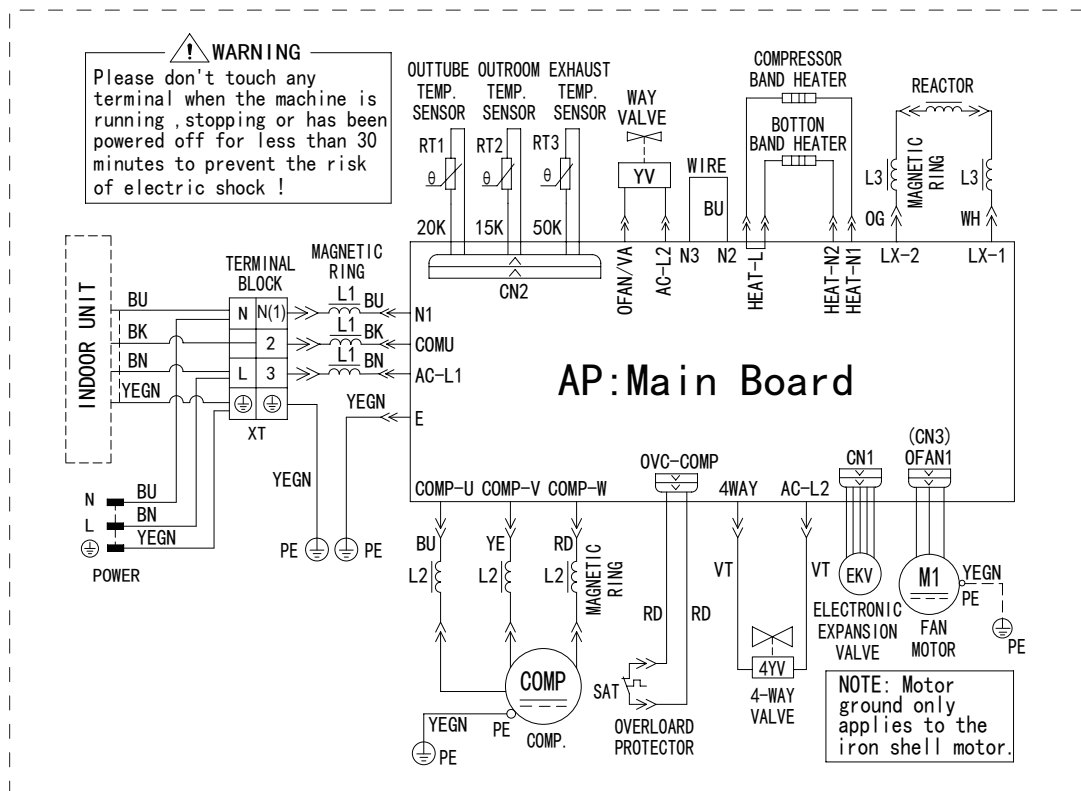

GWH18UC-K3DNA4F/O

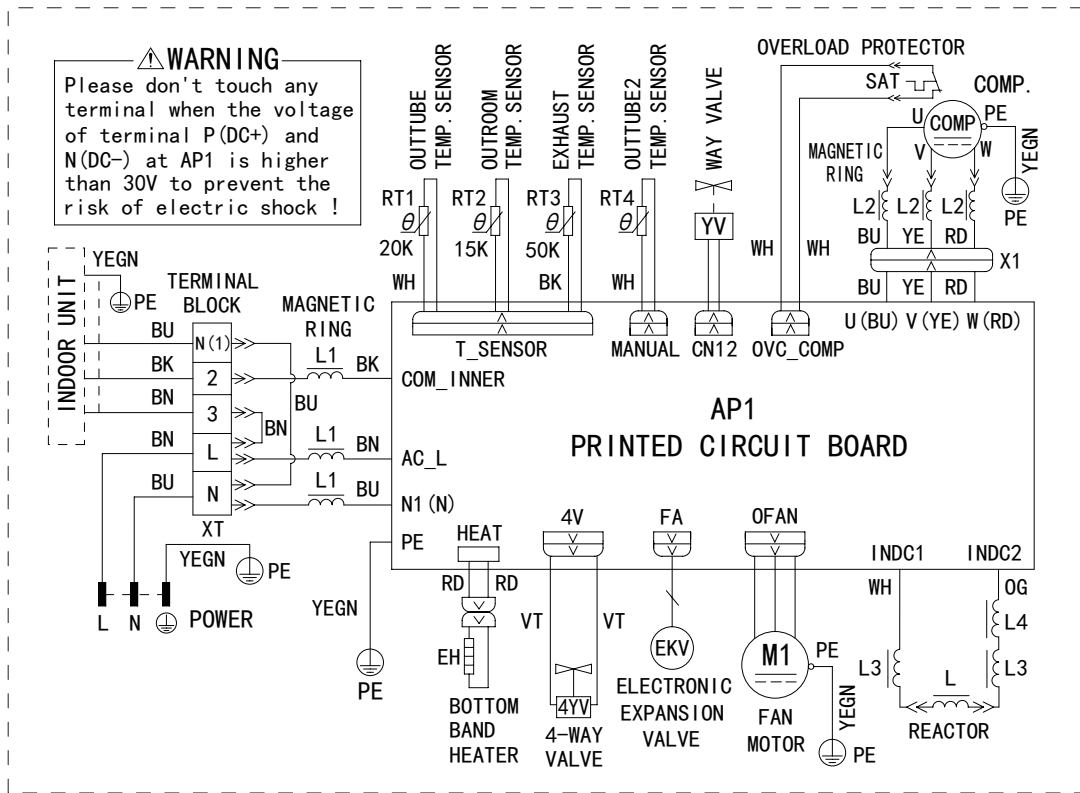

These wiring diagrams are subject to change without notice; please refer to the one supplied with the unit.

5.2 PCB Printed Diagram

Indoor Unit

09K/12K

• Top view

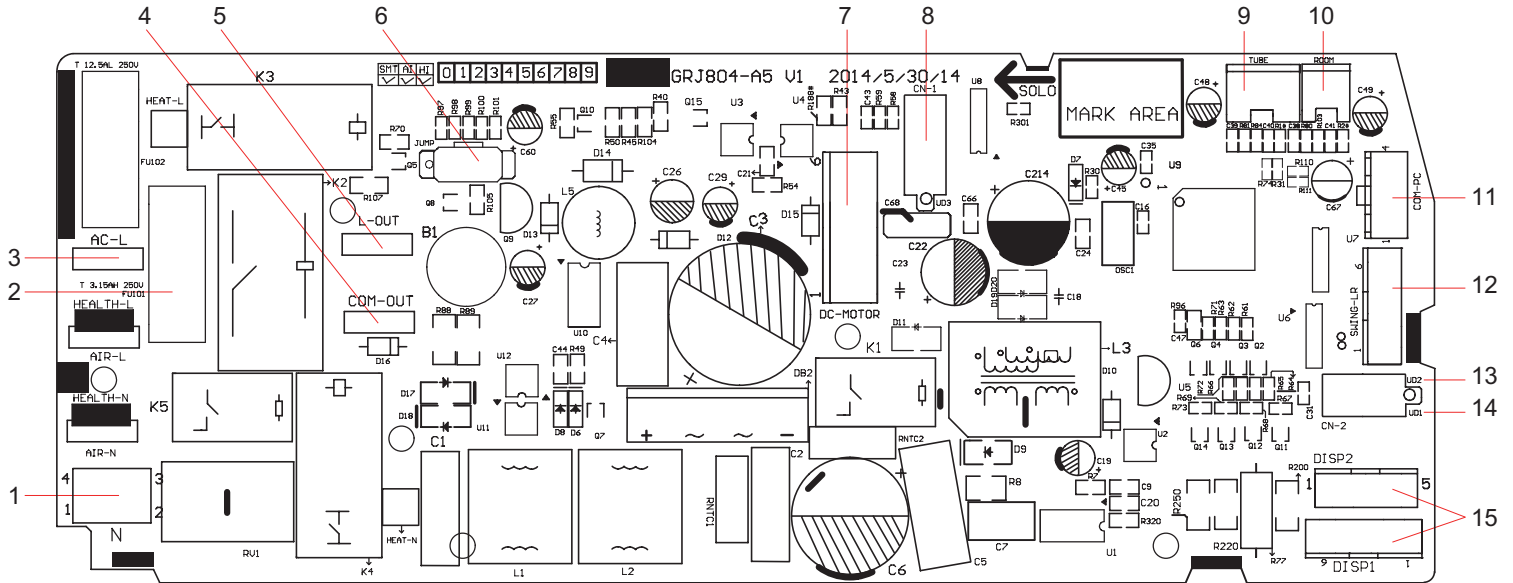

1	Interface of neutral wire	5	Interface of live wire for outdoor unit	9	Tube temperature sensor	13	Up&down swing 2
2	Interface of fuse	6	Interface of jumper cap	10	Ambient temperature sensor	14	Up&down swing 1
3	Interface of live wire	7	Indoor fan motor	11	Communication interface for radio-frequency, WIFI	15	Display interface
4	Interface of communication wire for neutral wire and live wire	8	Up&down swing 3	12	Interface of left&right swing	/	/

• Bottom view

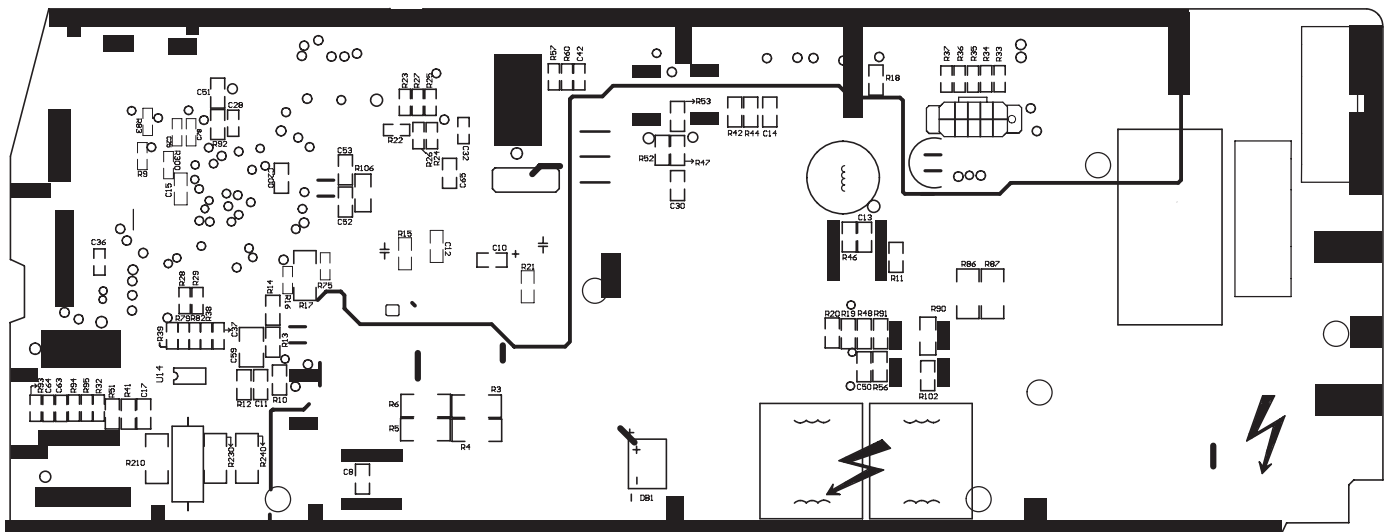

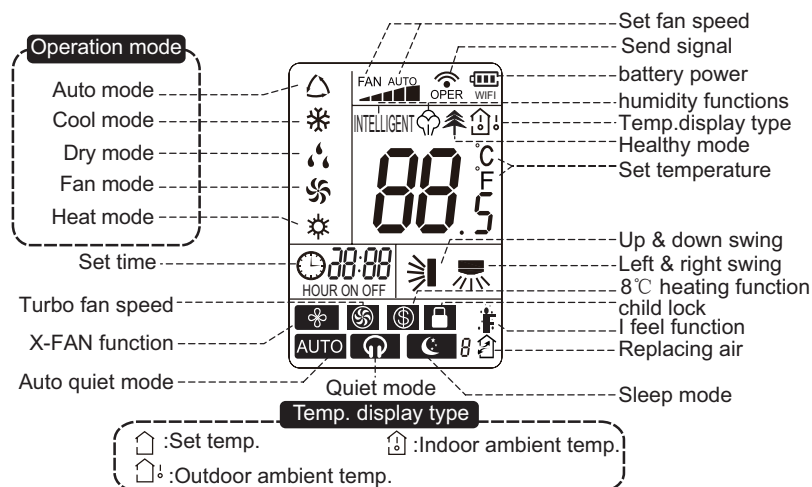

Introduction for Icons on Display Screen



Introduction for Buttons on Remote Controller

Note:

- After putting through the power, the air conditioner will give out a sound. Operation indicator "  " is ON (red indicator). After that, you can operate the air conditioner by using remote controller.
- Under on status, pressing the button on the remote controller, the signal icon "  " on the display of remote controller will blink once and the air conditioner will give out a "de" sound, which means the signal has been sent to the air conditioner.

1. ON/OFF Button

Press this button can turn on or turn off the air conditioner. After turning on the air conditioner, operation indicator "  " on indoor unit's display is ON (green indicator. The colour is different for different models), and indoor unit will give out a sound.

2. +/- button

Press "+" or "-" button once increase or decrease set temperature 0.5 °C. Holding "+" or "-" button, 2s later, set temperature on remote controller will change quickly. On releasing button after setting is finished, temperature indicator on indoor unit will change accordingly. (Temperature can't be adjusted under auto mode)

When setting TIMER , press "+" or "-" button to adjust time.







3. Cool button

Press this button, unit will operate in cool mode.

4. Heat button

Press this button, unit will operate in heat mode.

5. FAN button



Pressing this button can set fan speed circularly as: low(), low medium(), medium(), medium high(), high(), super(), auto(AUTO), quiet().



Note:

- Turbo function is not available under dry and auto mode.
- Automatically operate silent speed when starting sleep function.
- The unit operates at low speed under dry and auto dry mode. The speed can't be adjusted.
- Under AUTO speed, air conditioner will select proper fan speed automatically according to ambient temperature.



6. I FEEL button

Press this button to start I FEEL function and "  " will be displayed on the remote controller. After this function is set, the remote controller will send the detected ambient temperature to the controller and the unit will automatically adjust the indoor temperature according to the detected temperature. Press this button again to close I FEEL function and "  " will disappear.

- Please put the remote controller near user when this function is set. Do not put the remote controller near the object of high temperature or low temperature in order to avoid detecting inaccurate ambient temperature.

7.  button

Under simple swing mode, press this button can turn on (display "" icon) or turn off (not display "" icon) left&right swing function.

Under OFF status, press "+" button and "" button simultaneously can switch between simple swing mode and fixed swing mode. During switching time, "" icon on remote controller will flash twice.

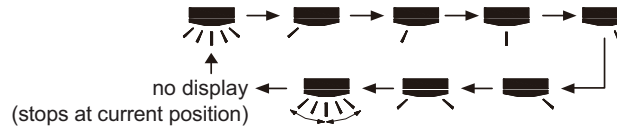

Under fixed-angle swing mode, press this button and the left and right swing status will change in the sequence as below:







8. MODE button

Press this button to select your required operation mode.





When selecting auto mode, air conditioner will operate automatically according to ambient temperature. Set temperature can't be adjusted and will not be displayed as well. Press "FAN" button can adjust fan speed. Press "" / "" button can adjust fan blowing angle.

After selecting cool mode, air conditioner will operate under cool mode. Press "+" or "-" button to adjust set temperature. Press "FAN" button to adjust fan speed. Press "" / "" button to adjust fan blowing angle.

When selecting dry mode, the air conditioner operates at low speed under dry mode. Under dry mode, fan speed can't be adjusted. Press "" / "" button to adjust fan blowing angle.

When selecting fan mode, the air conditioner will only blow fan, Press "FAN" button to adjust fan speed. Press "" / "" button to adjust fan blowing angle.

When selecting heating mode, the air conditioner operates under heat mode. Press "+" or "-" button to adjust set temperature. Press "FAN" button to adjust fan speed. Press "" / "" button to adjust fan blowing angle. (Cooling only unit won't receive heating mode signal. If setting heat mode with remote controller, press ON/OFF button can't start up the unit).

Note:

- For preventing cold air, after starting up heating mode, indoor unit will delay 1~5 minutes to blow air (actual delay time is depend on indoor ambient temperature).
- Set temperature range from remote controller: 16~30°C (61-86°F);

9.  button

Under simple swing mode, press this button can turn on (display "" icon) or turn off (not display "" icon) up&down swing function.

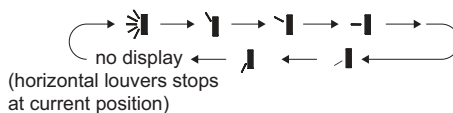

Under OFF status, press "+" button and "" button simultaneously can switch between simple swing mode and fixed swing mode. During switching time, "" icon on remote controller will flash twice.

Under fixed swing mode, press this button and up and down swing status will change in the sequence as below:





10. T-ON/T-OFF button

T-ON button

"T-ON" button can set the time for timer on. After pressing this button, "" icon disappears and the word "ON" on remote controller blinks. Press "+" or "-" button to adjust T-ON setting. After each pressing "+" or "-" button, T-ON setting will increase or decrease 1min. Hold "+" or "-" button, 2s later, the time will change quickly until reaching your required time. Press "T-ON" to confirm it. The word "ON" will stop blinking. "" icon resumes displaying. Cancel TIMER ON: Under the condition that T-ON is started up, press "T-ON" button to cancel it.

T-OFF button

"T-OFF" button can set the time for timer off. After pressing this button, "" icon disappears and the word "OFF" on remote controller blinks. Press "+" or "-" button to adjust T-OFF setting. After each pressing "+" or "-" button, T-OFF setting will increase or decrease 1min. Hold "+" or "-" button, 2s later, the time will change until reaching your required time. Press "T-OFF" to confirm it. The word "ON" will "OFF" will stop blinking. "" icon resumes displaying. Cancel T-OFF. Under the condition that T-OFF is started up, press "T-OFF" button to cancel it.

Note:

- Under on and off status, you can set T-OFF or T-ON simultaneously.
- Before setting T-ON or T-OFF, please adjust the clock time.
- After starting up T-ON or T-OFF, set the constant circulating valid. After that, air conditioner will be turned on or turned off according to setting time. ON/OFF button has no effect on setting. If you don't need this function, please use remote controller to cancel it.

11. CLOCK button

Press this button to set clock time. "🕒" icon on remote controller will blink. Press "+" or "-" button within 5s to set clock time. Each pressing of "+" or "-" button, clock time will increase or decrease 1 minute. Hold "+" or "-" button, 2s later, time will change quickly. Release this button when reaching your required time. Press "CLOCK" button to confirm the time. "🕒" icon stops blinking.

Note:

- Clock time adopts 24-hour mode.
- The interval between two operations can't exceeds 5s. Otherwise, remote controller will quit setting status. Operation for TIMER ON/TIMER OFF is the same.

12. Humidity/health button

Press this button to select your required operation mode.



Note:there is no this function for this unit. If press this button,the main unit will click, but it also runs under original status.

13. X-FAN button

Pressing this button in COOL or DRY mode, the icon "🌀" is displayed and the indoor fan will continue operation for 2 minutes in order to dry the indoor unit even though you have turned off the unit. After energization, X-FAN OFF is defaulted. X-FAN is not available in AUTO, FAN or HEAT mode.

This function indicates that moisture on evaporator of indoor unit will be blown after the unit is stopped to avoid mould.

- Having set X-FAN function on: After turning off the unit by pressing ON/OFF button indoor fan will continue running for about 2 min. at low speed. In this period, press X-FAN button to stop indoor fan directly.
- Having set X-FAN function off: After turning off the unit by pressing ON/OFF button, the complete unit will be off directly.

14. Air button

Press this button to select your required operation mode.

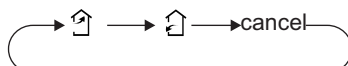

Note:there is no this function for this unit. If press this button,the main unit will click, but it also runs under original status.

15. LIGHT button

Pressing this button to turn off display light on indoor unit. Press this button again to turn on display light.

16. SLEEP button

Pressing this button can select Sleep 1, Sleep 2, Sleep 3, Sleep 4 or cancel Sleep circularly as below:

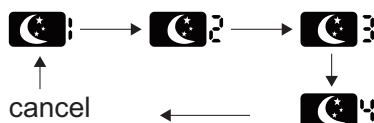

In Sleep 1 and Sleep 2, the air conditioner will run according to a group of presetting temperature curves.

- Sleep 3 - the sleep curve setting under DIY Sleep mode:

- (1) Under Sleep 3 mode, long press "AIR" button, the remote controller will enter the setting of personalized sleep. In this case, the timer zone of remote controller will display "1 hr" and the set temperature zone "88" will display the corresponding temperature of the last set sleep curve and blink (The first entering will display according to the initial curve setting value of manufacturer);
- (2) Press "+" and "-" button to adjust the corresponding temperature. After adjusting, press "AIR" button to confirm it;
- (3) At this time, the timer time on the remote controller will increase automatically by 1hr (that is "2 hr" or "3 hr" ... or "8 hr"). The set temperature zone "88" will display the corresponding temperature of the last set sleep curve and blink;
- (4) Repeat step(2) and step (3) until 8-hour temperature setting is finished, then the sleep curve is set successfully. After that, remote controller will resume displaying the original timer time and temperature zone will resume displaying the original set temperature.

- Sleep 3 - the sleep curve inquiry under DIY Sleep mode:

User can inquire the set sleep curve according to the setting method of sleep curve. Enter the setting of personalized sleep but do not change the temperature. Then press "AIR" button to confirm the setting.

Note: In the above setting or inquiry procedure, if there is no button pressing within 10s, remote controller will automatically exit the sleep curve setting and resume the original display. If ON/OFF, MODE, TIMER, HUMIDIFY, SLEEP, COOLING or HEATING button is pressed during the setting or inquiry procedure, remote controller will also exit the sleep curve setting.

- Sleep 4 is Siesta mode. The set temperature will change automatically according to the features of siesta.
- Sleep function will be disabled if the air condition is restarted after power failure; when sleep function is turned on, quite fan speed will be also turned on.
- Sleep function can not be set in AUTO mode.

17. Wifi button

Press this button 3s can set wifi function on or OFF.

At OFF status, press mode button and wifi button, can reset wifi mode parameter and open wifi function.

About X-FAN function

This function indicates that moisture on evaporator of indoor unit will be blown after the unit is stopped to avoid mould.

1. Having set X-FAN function on: After turning off the unit by pressing ON/OFF button indoor fan will continue running for about 2 min. at low speed. In this period, press X-FAN button to stop indoor fan directly.
2. Having set X-FAN function off: After turning off the unit by pressing ON/OFF button, the complete unit will be off directly.

About AUTO RUN

When AUTO RUN mode is selected, the setting temperature will not be displayed on the LCD, the unit will be in accordance with the room temp. automatically to select the suitable running method and to make ambient comfortable.

About lock

Press + and - buttons simultaneously to lock or unlock the keyboard. If the remote controller is locked, the icon  will be displayed on it, in which case, press any button, the mark will flicker for three times. If the keyboard is unlocked, the mark will disappear.

About switch between Fahrenheit and Centigrade

Under status of unit off, press MODE and - buttons simultaneously to switch °C and °F.

Operation guide

1. After putting through the power, press "ON/OFF" button on remote controller to turn on the air conditioner.
2. Press "MODE" button to select your required mode: AUTO, COOL, DRY, FAN, HEAT.
3. Press "+" or "-" button to set your required temperature. (Temperature can't be adjusted under auto mode).
4. Press "FAN" button to set your required fan speed: auto, low, medium and high speed.
5. Press "SWING" button to select fan blowing angle.

Replacement of batteries in remote controller

1. Press the back side of remote controller marked with "" as shown in the fig, and then push out the cover of battery box along the arrow direction.
2. Replace two 7# (AAA 1.5V) dry batteries, and make sure the position of "+" polar and "-" polar are correct.
3. Reinstall the cover of battery box.

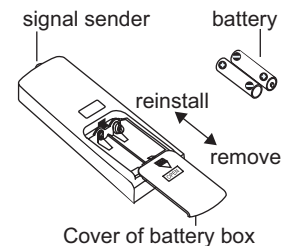

Battery level will be displayed on the remote controller. When "" is flickering, please replace the batteries, otherwise, remote controller can't operate normally.

Note:

- During operation, point the remote control signal sender at the receiving window on indoor unit.
- The distance between signal sender and receiving window should be no more than 26.25ft, and there should be no obstacles between them.
- Signal may be interfered easily in the room where there is fluorescent lamp or wireless telephone; remote controller should be close to indoor unit during operation.
- Replace new batteries of the same model when replacement is required.
- When you don't use remote controller for a long time, please take out the batteries.
- If the display on remote controller is fuzzy or there's no display, please replace batteries.

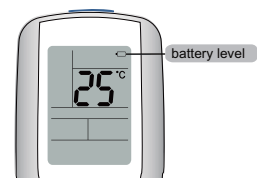

6.2 Operation of Smart Control (Smart Phone, Tablet PC)

Special Function

How to operate AC or auxiliary device with smart phone or tablet PC after matching:

First of all: before using smart connection function, please make sure your smart phone or tablet computer uses the standard Android or iOS operating system.

Please refer to the application program for the specific version. This air conditioner can connect 4 smart phones or tablet computers in maximum.

1. Install Gree-Smart on your smart phone/ tablet PC

Method 1: Enter Gree official website <http://www.gree.com/english/>. Search Gree-Smart Application in "Download Center".

Method 2: Scan the QR code and download the application directly (If your device is not compatible, please download the application in other ways.)



Method 3: Users of iOS system can search the application "Gree-Smart" through Apple's App Store. After it is successfully installed, you will see the picture below.

Following is the example using iPhone4s. (The interface of the application may vary as it is upgraded or used in different operating systems. Please refer to actual application.)

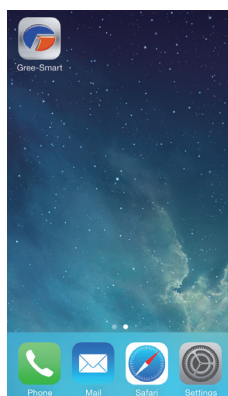

2. Turn on the AC WiFi:

Turn the AC on. First, make sure the remote controller is matched. Then, long-press "WiFi" button on the remote controller for at least 3 seconds. If WiFi icon is shown, it means the WiFi function is turned on.

3. Enter the WiFi setting of your phone and search for the wireless network named gree-xxxxxxx. Take gree-E9D1 as an example. Connect the network.

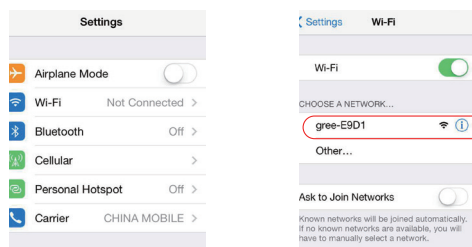

4. Input the original password 12345 to connect the network.

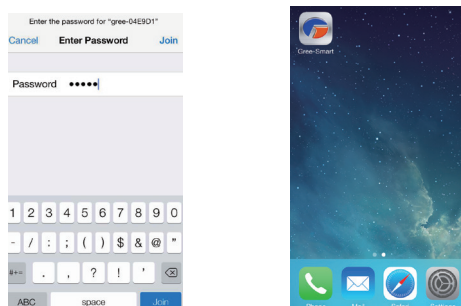

5. Open the application software and click “Refresh”, and then system will link with the air conditioner automatically. Click “⏻” to turn on the control function, and then click any position on the interface and then software will switch to the remote control interface.

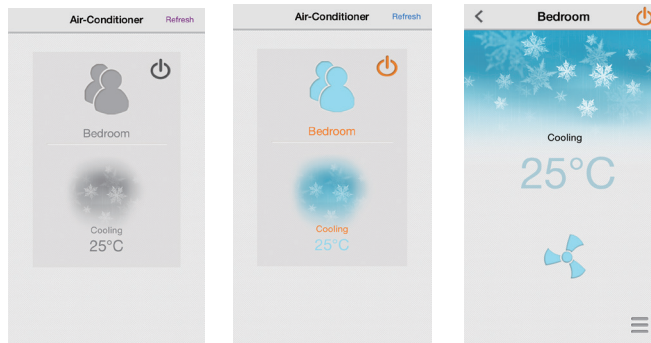

Attention: please change the name and key of the network during the first setting!

6. Left-slide the bottom function bar to “Settings” and click it to enter into internet setting interface. Click “Network Setting”, and input user name and password (the defaulted user name and password is admin) in the “Login” dialog box to enter into “Network Setting” to modify network name (e.g. gree-my home) and password (refer to the attachment: safe mode and password instruction).

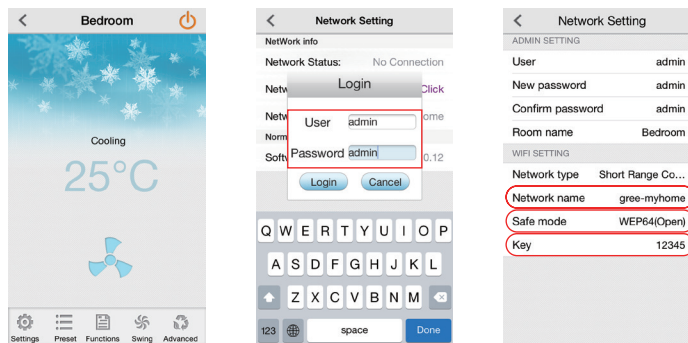

7. After modifying name and password, click it to return and there will be a prompt box, and then click “OK” to finish the modification. Meanwhile, the software will turn back to interface of “Air-Conditioner” and the AC list will be gone.

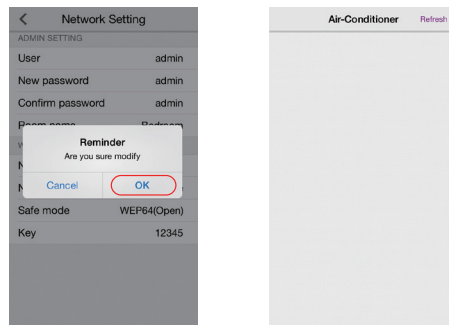

8. Exit the application and enter your phone’s WiFi Setting. Then you will see the network you just named “gree-my home”. Click it and input the password set in step 6 to join the network.

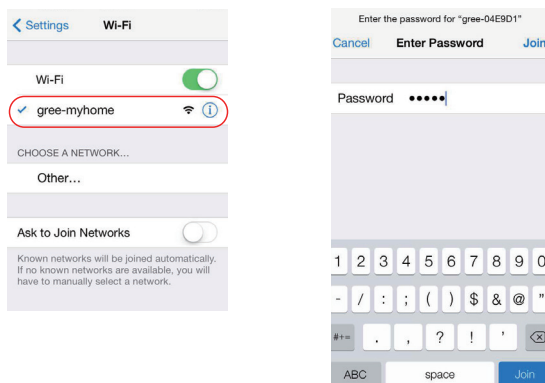

9. Enter into the software interface again. Meanwhile, the short-distance remote control setting for your air conditioner is finished.



How to reset the AC WiFi module:

Turn unit off with the remote controller and disconnect the power of AC. Then re-connect the power. 1 minute later, press “WiFi” and “Mode” buttons simultaneously. If the AC gives out a beep sound, it means the WiFi module is successfully reset. Attention: Operation of the buttons is only effective in 2 minutes.

Analysis on Common Network Setting Failure:

1. If short-distance control fails, please check the following items one by one!

- Make sure AC is power connected;
- Make sure AC's WiFi function is turned on as normal;
- Make sure your phone's WiFi selects the corresponding AC;
- Reset with the remote controller and then start setting again from step 3.

Kindly remind:

1. The air conditioner WiFi function needs about 1 minute to start up.
2. The air conditioner has memory function.
3. Those models have no long-distance control.

Function Introduction on Main Interface

1. Mode: It used for setting operation mode for air conditioner. You can select “Auto”, “Cooling”, “Drying”, “Fan” or “Heating” according to your requirement. Please refer to the part of remote controller for the detailed operation.



2. Temperature: It used for setting temperature. Set the indoor temperature according to your requirement.



3. Fan Speed: It used for setting fan speed. Under cooling or heating mode, if the noise-customized function is turned on, adjust the fan speed and then the noise-customized function will be turned off automatically. Please refer to the part of remote controller for detailed operation.



Key Functions Instruction of Application Software

1. Preset: It's with Timer On and Timer Off function. User can set Timer On and Timer Off according to actual individual requirement.

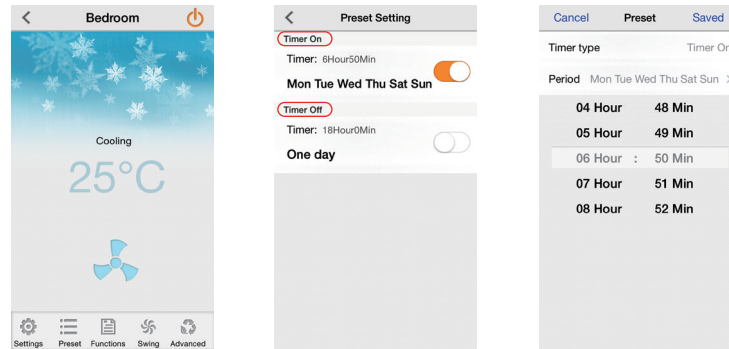

2. Functions: After entering setting interface, you can turn on or turn off Light, Purify, X-fan and Turbo functions and set Silent, Humidify, Air exchange and other modes. Please refer to the part of remote controller for the function instruction. Among that, Purify, Humidify, Air exchange functions can be set through equipping with special air purifier, humidifier. E-heater is not available for this unit.

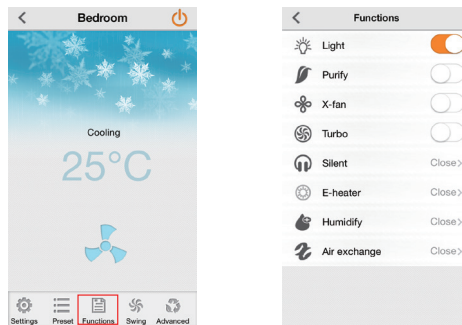

3. Swing: During up&down swing and left&right swing, it's the fixed angle swing when those two sliding blocks are combined together and full swing when they are separated. When setting up&down swing, the program will turn off regional swing function. However, no influence for regional swing when setting left&right swing.



4. Advanced: After entering advanced interface, you can set Sleep curve, Regional Swing, Noise and Power saving.

● Sleep curve: Sleep curve includes DIY mode, Traditional mode, Expert mode and Siesta mode. Under DIY mode, you can set temperature and time. Under auto mode and fan mode, sleep curve function can't be turned on. Only Traditional mode can be selected under dry mode.

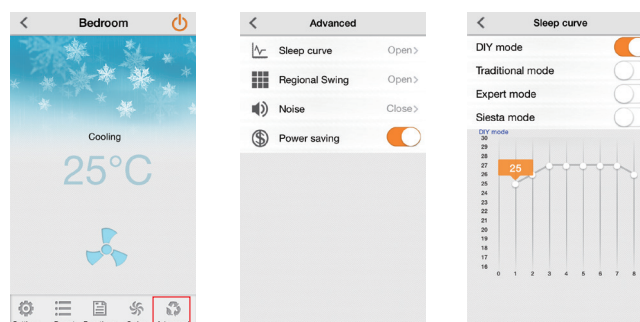

●Regional Swing: After entering Regional Swing, user can set it according to the room size. Press “Air flow position” button and the user can adjust the fan-blowing area through moving the icon of air conditioner left and right according to the actual installation position of the unit.

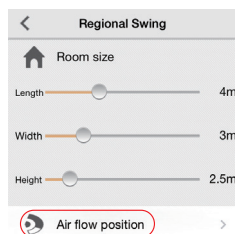

User can move the person icon among nine pane areas according to requirement to adjust the fan-blow area. The Regional Swing function can be turned off through up&down swing. The up&down swing in the Regional Swing is only valid under cooling and heating modes. The left&right swing area has relationship with the position of air conditioner set by mobile phone. The left&right swing position may be asymmetry, which is the normal phenomenon. “Avoid people” function can be turned on or turned off according to user’s personal experience. There may be deviation because of the installation position of air conditioner and the setting of parameters, which is the normal phenomenon.

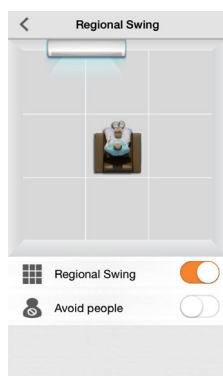

●Noise: The noise-customized function for indoor unit can be adjusted according to the actual individual requirement. The detailed adjustment range is different for different models, which is decided by indoor unit.

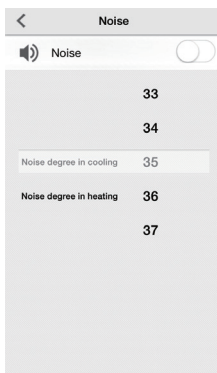

●Power saving: After energy saving navigation mode is turned on, the air conditioner will detect indoor temperature and outdoor temperature automatically. Meanwhile, the air conditioner will adjust frequency, fan speed and set temperature automatically according to the load status for saving energy.

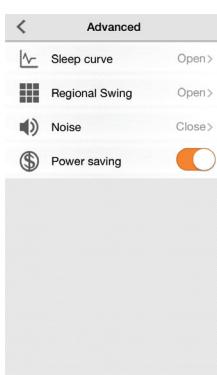

6.3 Brief Description of Modes and Functions

Conversion formula for Fahrenheit degree and Celsius degree: $T_f = T_c \times 1.8 + 32$

Indoor unit

1. This controller includes functions as below

(1) Auto; (2) Cooling; (3) Dry; (4) Fan; (5) Heating

2. Control object of controller

(1) Indoor unit :

Cooling mode: seven kinds of fan speed in total (including quiet, fan 1, fan 2, fan 3, fan 4, fan 5, turbo).

Heating mode: five kinds of fan speed in total (including quiet, fan 1, fan 2, fan 3, fan 4, fan 5, turbo).

Fan mode: Fan speed is same as that under cooling mode.

Dry mode: Low fan and quiet can be set under this mode. The fan speed is same as that for low fan under cooling mode.

Auto mode: Turbo is not available for this mode and the fan speed is same as that under each operation mode (cooling mode, fan mode, heating mode).

(2) Stepping motor for up&down swing.

(3) Stepping motor for swing mechanism.

(4) Stepping motor for left&right swing.

(5) E-heater.

(6) Health function (cold plasma reserved).

(7) Normal buzzer.

3. Basic functions of system

(1) Cooling mode

① Operation condition and process for cooling mode (refer to outdoor unit instruction for inverter unit).

② Protection function (refer to outdoor unit instruction for inverter unit).

(2) Dry mode

① Operation condition and process for dry mode.

② Protection function (refer to outdoor unit instruction for inverter unit).

(3) Heating mode (not for cooling only unit)

① Operation condition and process for heating mode.

② Defrosting condition and process (refer to outdoor unit instruction for inverter unit): As for normal intelligent defrosting; the unit will defrost automatically according to frosting condition and operation indicator will be on 10s and off 0.5s circularly. As for non-stop defrosting, the indoor fan will be started up according to the frosting condition and the operation indicator will be on 10s and off 0.5s circularly.

③ Protection function (refer to outdoor unit instruction for inverter unit).

(4) Fan mode

Under this mode, indoor fan operates at set fan speed. Compressor, outdoor fan, 4-way valve and electric heating tube all stop operation. Under this mode, the temperature setting range is 16~30°C . Operation icon and set temperature is displayed.

(5) Auto mode

Under auto mode, the system will select the operation mode (cooling, heating, fan) according to the change of ambient temperature. Operation icon, actual operation mode icon and set temperature will be displayed. There's 30s time delay for protection for mode switchover. Protection function is same as that under each mode.

4. Display status of indoor indicator

(1) Display status of indoor unit

① After energization, all display icons will be displayed and then only the power indicator is on. When turning on the unit with remote controller, the operation indicator is on and the current set operation mode will be displayed.

② During defrosting, the operation indicator will be on 10s and off 0.5s circularly. Under auto mode, the dual-8 nixie tube displays 25 under cooling mode or fan mode, and 20 under heating mode. Mode indicator is displayed according to the mode.

③ Dual-8 nixie tube displays set temperature.

(2) Error indicator display on indoor unit

Display table for error status		
Error name	Error definition	Dual-8 code display
Freon recovery mode	Operation status is displayed immediately	Fo
Malfunction of indoor fan	Malfunction of hardware	H6
Malfunction of middle temperature sensor of indoor evaporator	Malfunction of hardware	F2
Malfunction of indoor ambient temperature sensor	Malfunction of hardware	F1
Communication malfunction between indoor unit and outdoor unit	Malfunction of hardware	E6
Malfunction of jumper cap	Malfunction of hardware	C5
Limit/decrease frequency due to module current protection	Display through adjustment with remote controller	En
Limit/decrease frequency due to module temperature protection	Display through adjustment with remote controller	EU
Limit/decrease frequency due to overload protection	Display through adjustment with remote controller	F6
Limit/decrease frequency due to freeze prevention protection	Display through adjustment with remote controller	FH
Limit/decrease frequency due to discharge protection	Display through adjustment with remote controller	F9
Limit/decrease frequency due to AC current protection of outdoor unit	Display through adjustment with remote controller	F8
Malfunction overload temperature sensor	Malfunction of hardware	FE
Malfunction of outdoor discharge temperature	Malfunction of hardware	F5
Malfunction of outdoor ambient temperature sensor	Malfunction of hardware	F3
Malfunction of outdoor condenser temperature sensor	Malfunction of hardware	F4
Circuit malfunction of module temperature sensor	Malfunction of hardware	P7
Overload protection of compressor	Other malfunction	H3
Discharge protection	Other malfunction	E4
Overload protection	Other malfunction	E8
AC current protection of outdoor unit	Other malfunction	E5
Module current protection	Other malfunction	H5
Module temperature protection	Other malfunction	P8
Freeze prevention protection	Other malfunction	E2
High power protection	Other malfunction	L9
Lacking/inverse phase protection of compressor	Other malfunction	U2
PFC current malfunction	Other malfunction	HC
High DC bus bar voltage protection	Other malfunction	PH
Low DC bus bar voltage protection	Other malfunction	PL
Freon-lacking protection	Other malfunction	F0
Mode shock	Malfunction of hardware	E7
Non-matching between indoor unit and outdoor unit	Malfunction of hardware	LP
Read-write malfunction of memory chip	Malfunction of hardware	EE
Abnormal changeover for 4-way valve	Malfunction of hardware	U7
Malfunction of outdoor fan 2	Malfunction of hardware	LA
Malfunction of outdoor fan 1	Malfunction of hardware	L3
Low pressure protection	Other malfunction	E3
High pressure protection	Other malfunction	E1
Drop malfunction of DC bus bar voltage	Other malfunction	U3
Current detection malfunction for the complete unit	Malfunction of hardware	U5
Charging malfunction for capacity	Malfunction of hardware	PU
Phase current detection malfunction of compressor	Malfunction of hardware	U1
Desynchronizing of compressor	Other malfunction	H7
Demagnetizing protection of compressor	Other malfunction	HE
Failure startup of compressor	Other malfunction	Lc
High peak current of compressor	Other malfunction	P5
Conglutination malfunction of relay of refrigerant electric heater of outdoor unit	Malfunction of hardware	A2
Refrigerator heater of outdoor unit is invalid	Display through adjustment with remote controller	A3
Malfunction of temperature sensor of refrigerant heater	Malfunction of hardware	A4
Malfunction exit tube temperature sensor for condenser	Malfunction of hardware	A5
Oil return	Display through adjustment with remote controller	F7
Normal cooling and heating (capacity test code)	Operation status is displayed immediately	P1
Maximum cooling and heating (capacity test code)	Operation status is displayed immediately	P2
Medium cooling and heating (capacity test code)	Operation status is displayed immediately	P3
Minimum cooling and heating (capacity test code)	Operation status is displayed immediately	P0

of swing blade, there are upper swing and lower swing.

When selecting fixed-angle swing, you can select 5 kinds of swing position for blowing fan;

After selecting free swing, lower swing for heating mode and upper swing for cooling mode.

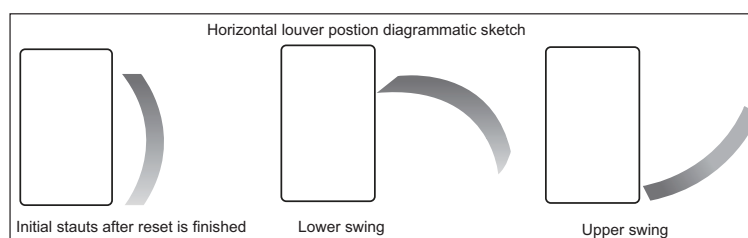

(12) Display

① Display of operation icon and mode icon

After energization, all icon will be displayed for once. Under standby status, operation icon will be in white. After turning on the unit with remote controller, the icon for the current operation mode will be displayed (mode: cooling, heating, 0.5, defrosting, frequency visual). After pressing light button to turn off light, all displays will be turned off. When turning on the unit, the backlight indicator will be turned on; when turning off the unit or light button, backlight indicator won't be turned on.

② Dual-8 nixie tube display

When turning on the unit after energization for the first time, the nixie tube is defaulted to display current set temperature (the temperature setting range is 16~30°C). When it received the signal of display set temperature, the nixie tube displays set temperature; when it received the signal of display ambient temperature, the nixie tube will display current indoor ambient temperature; if remote control to set other status, the display won't change. F1 will be displayed for the malfunction of ambient temperature sensor; F2 will be displayed for the malfunction of indoor tube temperature sensor; C5 will be displayed for the malfunction of jumper cap.

(13) Locked protection to motor

After turning on the fan, when the motor operates at low speed for a period of time, it will stop operation for preventing auto protection of motor and lockage will be displayed. If it's at on status, dual-8 nixie tube displays lockage error code H6; if it's at off status, lockage information won't be displayed.

6. Special Functions

(1) Rf control function

There are three optional mode—air, humidify and air purifier. After matching is succeeded, you can control the related mode through remote controller.

(2) I Feel function

When I FEEL command is received, the controller will operate according to the ambient temperature sent by the remote controller (For defrosting and cold blow prevention, the unit operates according to the ambient temperature sensed by the air conditioner). The remote controller will regularly send ambient temperature data to the controller. When the data has not been received for a long time, the unit will operate according to the temperature sensed by the air conditioner. If I FEEL function is not selected, the ambient temperature will be that sensed by the air conditioner. I FEEL function is not to be memorized.

(3) Malfunction detecting of temperature sensor

When it detected that there's malfunction of indoor ambient temperature sensor, it will display F1; when it detected that there's malfunction of indoor tube temperature sensor, it will display F2.

(4) Low power consumption standby function

When the air conditioner is in power off and at standby status, it will enter into low power consumption standby status 6 minutes later, and the operation indicator will be turned off.

7. Error Analysis

(1) Error 1: No response after energization, and buzzer does not give out a beep.

Solution: Please check the power supply or replace the controller.

(2) Error 2: Dual-8 nixie tube of display board displays "C5".

Solution: The jumper cap has not been firmly connected to the controller, please reinsert or replace the jumper cap with the same specification.

(3) Error 3: Dual-8 nixie tube of display board displays "F1".

Solution: The ambient temperature sensor of air conditioner has not been firmly connected to the controller, please reinsert or replace an ambient temperature sensor.

(4) Error 4: Dual-8 nixie tube of display board displays "F2".

Solution: The tube temperature sensor of air conditioner has not been firmly connected to the controller, please reinsert or replace a tube temperature sensor.

(5)Error 5: Dual-8 nixie tube of display board displays “H6”.

Solution: The feedback wire of indoor fan has not been firmly connected to the controller or the indoor fan motor fails to work, please reinsert the feedback line of indoor fan or replace the main board of controller, or replace the motor.

(6)Error 6: Dul-8 nixie tube of display board displays “FC”.

Solution: It is malfunction of swing mechanism, which is caused by the looseness of connecting wire or damage of swing mechanism or main board. Please reconnect the connecting wire, or replace the swing mechanism or controller.

(7)Error 7: Dul-8 nixie tube of display board displays “JF” or “rF”.

Solution: It is abnormal of detecting board, which is caused by the looseness of communication line between the main board and detecting board, or the malfunction of detecting board or main board. Please reinsert the connecting wire, or replace the detecting board or controller.

8.Blockage protection to Motor

(1) When turning on the fan, the motor speed is not more than 300rpm/min for 1 min consecutively, it's blockage protection to motor.

(2)During lockage protection to motor, all load stop operation (indoor fan, outdoor fan, compressor, and electric heating tube stop operation; 4-way valve should delay 2mins to stop operation and then horizontal louver will stop at the current position.

(3)Once there's blockage protection to motor, cut off the power to resume operation.

(4)During blockage protection to motor, remote controller and buttons are valid and they can turn on or turn off the unit, while they won't perform detailed target (indoor fan, outdoor fan, compressor, and electric heating tube stop operation, and 4-way valve should delay 3mins to stop operation; horizontal louver will stop at current position).

(5)During motor blockage protection, if the unit is at on status, the dual-8 nixie tube displayed blockage error code H6; if the unit is at off status, it won't display blockage malfunction information.

9.Communication malfunction

If the unit hasn't received correct signal for 3mins consecutively, it's the communication malfunction. Outdoor fan stop operation and stop operation after blowing residual heat under auto heating mode or heating mode. Indoor fan operated at set fan speed under other modes.

10.Auto inspection function

Maflunction of jumer cap

After energization, when it's detected the jumper cap outlet is blank, it's the malfunction of jumper cap, which can't resumed. During malfunction protection of jumper cap, if the unit is at on status, the nixie tube displays error code: “C5” and operation indicator is blinking. If the unit is at off status, it won't display error code.

Note: The controller without this function won't detection this malfunction.

Outdoor unit

09K/12K

1. System function

1.1 Cooling mode

1.1.1 Working condition and process for cooling

When the compressor is at off status, turn on the unit under cooling mode. When indoor unit reaches the condition of turning on the unit, the unit operates under cooling mode. Meanwhile, indoor fan, outdoor fan and compressor stops operation.

1.1.2 Stop operation under cooling mode

Compressor stopped operation, compressor stops operation immediately and outdoor fan delay 30s to stop operation.

1.1.3 Switch to heating mode from cooling mode

When switching to heating mode, 4-way will delay 3min to be energized after compressor is stopped. Others are same with that stopped operation under cooling mode.

1.1.4 4-way valve: 4-way valve will be closed under this mode

1.1.5 Outdoor fan control under cooling mode

After compressor stops operation, outdoor fan will operate at current fan speed for another 30s and then stops operation.

1.2 Drying mode

1.2.1 Working condition and process for drying mode: same with that for cooling mode

1.2.2 Status of 4-way valve: OFF.

1.2.3 Temperature setting range: 16~30°C.

1.2.4 Protection function: Same with that under cooling mode.

1.2.5 The startup condition for electronic expansion valve, outdoor fan and compressor is same as that for cooling mode.

1.3 Heating mode

1.3.1 Working condition and process for heating mode

When indoor unit reaches the startup condition of heating, indoor unit will operate under heating mode.

1.3.2 Stop operation under heating mode:

a. When indoor unit reached OFF or stop operation conditioner, compressor stop operation, and outdoor fan will delay 1min to stop operation.

b. Switch to cooling(drying) or fan mode

(a) compressor stops operation; (b) 4-way valve will delay 2min to be de-energized;

(c) outdoor fan will delayed 30s to stop operation; (d) status of 4-wayvalve: energized.

1.3.3 Outdoor fan control under heating mode

When compressor stops operation, outdoor fan will delay 30s to stop operation.

1.3.4 Defrosting function

When it satisfied defrosting condition, compressor stops operation. After compressor stopped for 30s, outdoor fan stops operation and 4-way valve will change direction; After 4-way valve chaging direction, compressor will be startup, defrosting will start counting time and compressor frquency will be increased to defrosting frequency.

1.4 Fan mode

1.4.1 Compressor, outdoor fan and 4-way valve will all be stopped or closed.

1.4.2 Temperature setting range is 16~30°C.

2. Protection function

2.1 Overload protection function

During cooling mode, measure the temperature of outdoor heat exchanger; during heating mode, measure the temperature of indoor heat exchanger.

(1)When $T_{tube} \leq T1$, resume original operation status;

(2)When $T_{tube} \geq T2$, prohibit increasing frequency;

(3)When $T_{tube} \geq T3$, compressor will decrease frequency to operate.

(4)When $T_{tube} \geq T4$, compressor stops operation;

During cooling or drying mode: $T1=52$; $T2=55$; $T3=58$; $T4=62$;

During heating mode: $T1=50$; $T2=53$; $T3=56$; $T4=60$;

Under auto heating or heating mode, indoor unit will stop operation after blow residual heat. Under other modes, indoor fan operates at set fan speed.

2.2 Delay protection of compressor

When compressor is stopped, it needs 3min to restart up the compressor. Once compressor is started up, compressor won't stop operate within 6in according to the change of temperature.

2.3 Discharge temperature protection of compressor

- (1)When TBdischarge $B \geq 98^{\circ}\text{C}$, prohibit increasing frequency;
- (2)When TBdischarge $B \geq 103^{\circ}\text{C}$, prohibit decreasing frequency;
- (3)When TBdischarge $B \geq 110^{\circ}\text{C}$, compressor stops operation;
- (4)When TBdischarge $B \leq 90^{\circ}\text{C}$, protection is released.

2.4 Communication malfunction

When the unit hasn't received correct signal for 3mins consecutively, it's the communication malfunction. The complete unit will stop operation.

2.5 Module protection

During module protection, compressor stops operation. When compressor has stopped operation for 3min, compressor will resume operation. When module protection occurs all the time when starting up compressor for 6 times consecutively, compressor can't be started any more (turn off the unit with remote controller can clear up module, and the accumulative times of module protection).

When the operation time of compressor is more than 6mins, the accumulative times will be cleared up.

2.6 When DC bus voltage is lower than 150V or more than 420V, compressor will delay 30s to stop operation. When DC bus voltage is more than 200C and less than 400V, protection will be resumed. Compressor will resume operation after it has stopped for 3mins. During low pressure protection, main relay will break off. When low voltage protection is resumed, main relay will be closed.

2.7 When overload malfunction is occurred, compressor stopped operation and outdoor fan will delay 30s to stop operation; when malfunction is cleared up and compressor has stopped for 3min, the unit will resume operation.

2.8 Power protection of compressor

- (1)When PCB $\geq 1500\text{w}$, prohibit increasing frequency;
- (2)When PCB $\geq 1600\text{w}$, decrease frequency to operate;
- (3)When PCB $\geq 1700\text{w}$, compressor stops operation;
- (4)When PCB $\leq 1400\text{w}$, protection is released.

2.9 Malfunction of temperature sensor

Name of temperature sensor	Malfunction condition
Outdoor ambient	It's detected that the temperature sensor is open/short-circuited for 5s consecutively
Outdoor tube temperature	It's detected that the temperature sensor is open/short-circuited for 5s consecutively; it won't be detected within 10mins after defrosting
Air discharge	After compressor operates for 3min,it's detected that the temperature sensor is open/short-circuited for 5s consecutively

2.10 When outdoor fan is open-circuited or current is more than 0.8aA, outdoor fan will stop operation and then be restarted up 4s later. If the fan stops operation for 6 times successively, it's the malfunction of fan. And then compressor will stops operation. 3mins later, the malfunction of fan will be cleared and restart up outdoor fan and compressor. If malfunction of fan occurs for 6 times successively, outdoor fan won't be restarted up. Turn off the unit with remote controller can clear up malfunction and the accumulated timer of malfunction. After compressor operates for 6mins successively, the accumulated malfunction times of fan will be cleared.

18K

1. Compensation function of input parameters

According to the structure of wall-mounting unit, considering the comfortability for operation, indoor ambient temperature when the compressor is at OFF status is higher than set temperature under heating mode.

2. Control of detecting the availability of parameters

For ensuring the safety and reliability of operation, please insert the outdoor discharge temperature sensor into the corresponding temperature sensor bushing to make sure that the control system can detect system discharge temperature accurately. Otherwise, the unit will stop operation and it displays malfunction of discharge temperature sensor (discharge temperature sensor hasn't been inserted well), which can only be resumed by pressing ON/OFF button on remote controller. Basic functions:

3. Cooling mode

3.1 Working condition and process for cooling

3.1.1 If compressor is at OFF status, and $(T_{\text{preset}} - (T_{\text{indoor amb.}} - \Delta T_{\text{indoor amb. compensation of cooling}})) \leq 0^{\circ}\text{C}$, the unit operates in cooling mode;

3.1.2 During cooling operation, if $0^{\circ}\text{C} \leq (T_{\text{preset}} - (T_{\text{indoor amb.}} - \Delta T_{\text{indoor amb. compensation of cooling}})) < 3^{\circ}\text{C}$, the unit still operates in cooling mode;

3.1.3 During cooling operation, if $3^{\circ}\text{C} \leq (T_{\text{preset}} - (T_{\text{indoor amb.}} - \Delta T_{\text{indoor amb. compensation of cooling}}))$, the unit stops operation when reaching the temperature point in cooling.

3.2 Temperature setting range:

3.2.1 If $T_{\text{outdoor amb.}} \geq T_{\text{cooling temperature (low temperature)}}$, the temperature setting range is 16-30°C (cooling in room temperature);

3.2.2 If $T_{\text{outdoor amb.}} < T_{\text{cooling temperature (low temperature)}}$, the temperature setting range is 25-30°C. That is: the lower limit of set temperature for outdoor unit is 25°C.

4. Dry mode

4.1 Working conditioner and process for drying is same as that for cooling mode;

4.2 Temperature setting range is 16-30°C;

5. Fan mode

5.1 Compressor, outdoor fan and 4-way valve are all turned off;

5.2 Temperature setting range is 16-30°C.

6. Heating mode

6.1 Working conditioner and process of heating: ($T_{\text{indoor amb.}}$ is the actual temperature detected by indoor ambient temperature sensor; $\Delta T_{\text{indoor amb. compensation of heating}}$ is indoor ambient temperature compensation during heating operation).

6.1.1 If compressor is at OFF status, and $(T_{\text{indoor amb.}} - \Delta T_{\text{indoor amb. compensation of heating}}) - T_{\text{preset}} \leq -1^{\circ}\text{C}$, the unit operates in heating mode.

6.1.2 During heating operation, if $0^{\circ}\text{C} \leq ((T_{\text{indoor amb.}} - \Delta T_{\text{indoor amb. compensation of heating}}) - T_{\text{preset}}) < 2^{\circ}\text{C}$, the unit still operates in heating mode.

6.1.3 During heating mode, if $2^{\circ}\text{C} \leq ((T_{\text{indoor amb.}} - \Delta T_{\text{indoor amb. compensation of heating}}) - T_{\text{preset}})$, the unit stops operation when reaching the temperature point in heating.

6.2 Under this mode, the temperature setting range is 16-30°C.

7. Defrosting control (heating mode)

7.1 If it turns to defrosting time and it detected that the defrosting temperature is satisfied for 3mins successively, the unit turns into defrosting process.

7.2 Defrosting-starting: compressor stops operation and restart it up after 55s delayed,

7.3 Defrosting-ending: Compressor stops operation and it starts up after 55s delayed.

7.4 When any one of below defrosting-ending conditions is satisfied, the unit will quit from defrosting operation:

7.4.1 $T_{\text{outdoor tube}} \geq T_{\text{quit temperature 1}}$ for defrosting;

7.4.2 Defrosting operation time is reached $T_{\text{max. defrosting time}}$.

8. Control of compressor

8.1 Frequency of compressor intangibly controls the frequency according to the relation between ambient temperature and set temperature, and the change speed of ambient temperature;

8.2 Under cooling, heating or drying mode, compressor will be started up after outdoor fan is started for 5s.

8.3 At the OFF status, stop operation because of protection and switchover to fan mode, the compressor stops operation immediately.

8.4 Under each mode: Once the compressor is started up, it can be stopped only after operation.

8.5 Under each mode, once the compressor is stopped, it can be restarted up only after 3min delayed

9. Control of outdoor fan

9.1 When turn off the unit by remote controller, stop operation because of protection or stop operation after reaching the temperature point, outdoor fan can stop operation only after the compressor is stopped for 1min;

9.2 Under fan mode: outdoor fan stops operation.

9.3 defrosting-starting: enter into defrosting. Outdoor fan stops operation after compressor stops for 50s.

9.4 Defrosting-ending: quit defrosting. When the compressor stops operation, the outdoor fan operates.

10. Control of 4-way valve

10.1 4-way valve status under cooling, drying and fan modes: OFF;

10.2 When the unit turned on and operated in heating mode, the 4-way valve is energized immediately.

10.3 If turn off unit or switch to other mode in heating mode, the 4-way valve is de-energized after the compressor stops for 2min;

10.4 When the unit is turned off because of each protection, the 4-way valve is de-energized after 4 mins delayed.

10.5 Defrosting-starting: enter into defrosting. After the compressor stops for 50s, the 4-way valve will be de-energized.

10.6 Defrosting-ending: quit defrosting. After the compressor stops for 50s, the 4-way valve is energized.

11. Freeze protection

11.1 Under cooling or drying mode, if it's detected that $T_{\text{inner tube}} < 0$ for 3min successively, the unit will stop operation due to freeze protection. If $T_{\text{limit temperature of freeze protection}} < T_{\text{inner tube}}$, and compressor stops for 3min, the complete can resume operation;

11.2 Under cooling or drying mode, if $T_{\text{inner tube}} < 6$, the operation frequency of compressor may increase or decrease;

11.2.1 If the unit is stopped because of freeze protection for 6 times successively, it can't resume operation automatically and the malfunction will be displayed continuously, which can only be resumed by pressing ON/OFF button. During operation, if operation time of compressor is over, the times of stop operation because of freeze protection will be cleared. If turn off the unit or switch to fan/heating mode, malfunction and times of malfunction is eliminated immediately.

12. Overload protection

12.1 Overload protection under cooling or drying mode: If $T_{\text{overload stop operation temp. in cooling}} \leq T_{\text{outdoor tube}}$, the unit stops operation because of overload in cooling; if $T_{\text{outdoor tube}} < T_{\text{overload limit-frequency temp in cooling}}$ and the compressor has stopped for 3min, the complete unit can resume operation.

12.2 Under cooling or drying mode, if $T_{\text{overload limit-frequency temp. in cooling}} \leq T_{\text{outdoor tube}}$, the frequency of compressor may increase or decrease;

12.3 Overload protection under heating mode: If $T_{\text{overload stop operation temp. in heating}} \leq T_{\text{indoor tube}}$, the unit stops operation because of overload in heating; if $T_{\text{indoor tube}} < T_{\text{overload limit-frequency temp. in heating}}$ and the compressor has stopped for 3min, the complete unit can resume operation.

12.4 Under heating mode. If $T_{\text{overload limit-frequency temp. in heating}} \leq T_{\text{indoor tube}}$, operation frequency of compressor may increase or decrease;

12.5 If the unit is stopped because of overload protection for 6 times successively, it can't resume operation automatically and the malfunction will be displayed continuously, which can only be resumed by pressing ON/OFF button. During operation, if operation time of compressor is over, the times of stop operation because of overload protection will be cleared. If turn off the unit, fan or switch to fan/heating mode, malfunction and times of malfunction is eliminated immediately.

13. Discharge temperature protection of compressor

13.1 If $T_{\text{stop operation temperature for discharge}} \leq T_{\text{discharge}}$, the unit stops operation because of discharge protection; If $T_{\text{discharge}} < T_{\text{limit-frequency temperature for discharge}}$ and compressor has stopped for 3min, the complete unit can resume operation;

13.2 If $T_{\text{normal speed decrease-frequency for discharge}} \leq T_{\text{discharge}}$, operation frequency of compressor may decrease or increase;

13.3 If the unit is stopped because of discharge protection of compressor for 6 times successively, it can't resume operation automatically, which can only be resumed by pressing ON/OFF button. During operation, if operation time of compressor is over, the times of stop operation because of discharge protection will be cleared. If turn off the unit, or switch to fan/heating mode, malfunction and times of malfunction is eliminated immediately.

14. Current protection function

14.1 If $13A \leq I_{\text{AC current}}$, operation frequency of compressor may decrease or increase;

14.2 If $17A \leq I_{\text{AC current}}$, the system will stop operation because of overcurrent; the complete unit can resume operation only after the compressor stops for 3min;

14.3 If the unit is stopped because of overcurrent for 6 times successively, it can't resume operation automatically, which can only be resumed by pressing ON/OFF button. During operation, if operation time of compressor is over, the times of stop operation because of overcurrent protection will be cleared.

15. Voltage drop protection

During operation of compressor, if the voltage is decreasing quickly, the system may stop operation and voltage drop malfunction is caused. 3min later, the system will be restarted up automatically.

16. Communication malfunction

When it hasn't received the correct signal from indoor unit for 3min, the unit will stop operation because if communication malfunction; if communication malfunction is eliminated and compressor has stopped for 3in, the complete unit can resume operation.

17. OPM module protection

After compressor is turned on, if the overcurrent happens for IPM module, or control voltage is too low because of abnormal causes, IPM will detect module protection signal immediately. Once it detected the module protection signal, the unit will stop operation because of module protection. If module protection is resumed and compressor has stopped for 3min, the complete unit will resume operation.

If the unit is stopped because of module protection for 3 times successively, the unit can resume operation automatically unless press ON/OFF button. If the operation time for compressor is over, the times of stop operation because of module protection will be cleared.

18. Overheat protection of module

18.1 If $T_{\text{normal speed frequency-decreasing temp. of module}} \leq T_{\text{module}}$, the operation frequency of compressor may decrease or increase;

18.2 If $T_{\text{stop operation temperature of module}} \leq T_{\text{module}}$, the syste will stop operation for protection. If $T_{\text{module}} < T_{\text{frequency-limiting temperature of module}}$ and compressor has stopped for 3min, the complete unit will resume operation;

18.3 If the unit is stopped because of overheating of compressor module for 6 times successively, it can't resume operation automatically, which can only be resumed by pressing ON/OFF button. During operation, if operation time of compressor is over, the times of stop operation because of compressor overheating protection will be cleared. If turn off the unit, or switch to fan mode, times of malfunction is eliminated immediately.

19. Overload protection of compressor

19.1 If it detected that the overload switch for compressor is open for 3min successively, the complete unit will stop operation for protection;

19.2 If overload protection is resumed and compressor has stopped for 3min, the complete unit can resume operation;

19.3 If the unit stops operation because of overload protection for compressor for 3times successively, it can't resume operation automatically, which can only be resumed by pressing ON/OFF button. After compressor has operated for 30min, overload protection times for compressor will be eliminated.

Part II : Installation and Maintenance

7. Notes for Installation and Maintenance

Safety Precautions: Important!

Please read the safety precautions carefully before installation and maintenance.

The following contents are very important for installation and maintenance.

Please follow the instructions below.

- The installation or maintenance must accord with the instructions.
- Comply with all national electrical codes and local electrical codes.
- Pay attention to the warnings and cautions in this manual.
- All installation and maintenance shall be performed by distributor or qualified person.
- All electric work must be performed by a licensed technician according to local regulations and the instructions given in this manual.
- Be caution during installation and maintenance. Prohibit incorrect operation to prevent electric shock, casualty and other accidents.



Warnings

Electrical Safety Precautions:

1. Cut off the power supply of air conditioner before checking and maintenance.
2. The air condition must apply specialized circuit and prohibit share the same circuit with other appliances.
3. The air conditioner should be installed in suitable location and ensure the power plug is touchable.
4. Make sure each wiring terminal is connected firmly during installation and maintenance.
5. Have the unit adequately grounded. The grounding wire can't be used for other purposes.
6. Must apply protective accessories such as protective boards, cable-cross loop and wire clip.
7. The live wire, neutral wire and grounding wire of power supply must be corresponding to the live wire, neutral wire and grounding wire of the air conditioner.
8. The power cord and power connection wires can't be pressed by hard objects.
9. If power cord or connection wire is broken, it must be replaced by a qualified person.

10. If the power cord or connection wire is not long enough, please get the specialized power cord or connection wire from the manufacture or distributor. Prohibit prolong the wire by yourself.

11. For the air conditioner without plug, an air switch must be installed in the circuit. The air switch should be all-pole parting and the contact parting distance should be more than 3mm.

12. Make sure all wires and pipes are connected properly and the valves are opened before energizing.

13. Check if there is electric leakage on the unit body. If yes, please eliminate the electric leakage.

14. Replace the fuse with a new one of the same specification if it is burnt down; don't replace it with a cooper wire or conducting wire.

15. If the unit is to be installed in a humid place, the circuit breaker must be installed.

Installation Safety Precautions:

1. Select the installation location according to the requirement of this manual.(See the requirements in installation part)
2. Handle unit transportation with care; the unit should not be carried by only one person if it is more than 20kg.
3. When installing the indoor unit and outdoor unit, a sufficient fixing bolt must be installed; make sure the installation support is firm.
4. Ware safety belt if the height of working is above 2m.
5. Use equipped components or appointed components during installation.
6. Make sure no foreign objects are left in the unit after finishing installation.

Refrigerant Safety Precautions:

1. Avoid contact between refrigerant and fire as it generates poisonous gas; Prohibit prolong the connection pipe by welding.
2. Apply specified refrigerant only. Never have it mixed with any other refrigerant. Never have air remain in the refrigerant line as it may lead to rupture or other hazards.
3. Make sure no refrigerant gas is leaking out when installation is completed.
4. If there is refrigerant leakage, please take sufficient measure to minimize the density of refrigerant.
5. Never touch the refrigerant piping or compressor without wearing glove to avoid scald or frostbite.

Improper installation may lead to fire hazard, explosion, electric shock or injury.

Main Tools for Installation and Maintenance

<p>1. Level meter, measuring tape</p> 	<p>2. Screw driver</p> 	<p>3. Impact drill, drill head, electric drill</p> 
<p>4. Electroprobe</p> 	<p>5. Universal meter</p> 	<p>6. Torque wrench, open-end wrench, inner hexagon spanner</p> 
<p>7. Electronic leakage detector</p> 	<p>8. Vacuum pump</p> 	<p>9. Pressure meter</p> 
<p>10. Pipe pliers, pipe cutter</p> 	<p>11. Pipe expander, pipe bender</p> 	<p>12. Soldering appliance, refrigerant container</p> 

8. Installation

8.1 Installation Dimension Diagram

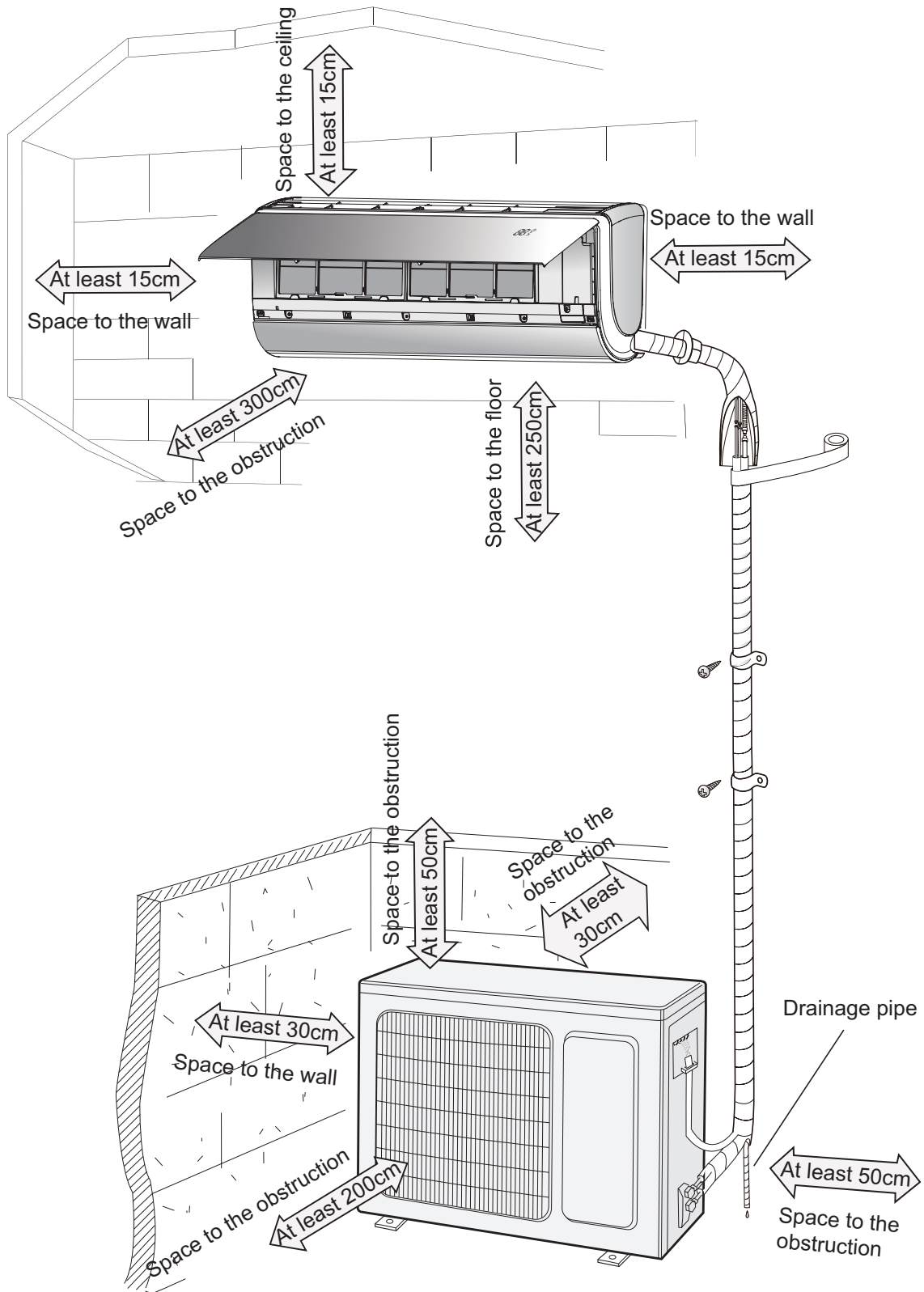

8.2 Installation Parts-checking

NO.	Name	NO.	Name
1	Indoor unit	8	Sealing gum
2	Outdoor unit	9	Wrapping tape
3	Connection pipe	10	Support of outdoor unit
4	Drainage pipe	11	Fixing screw
5	Wall-mounting frame	12	Drainage plug(cooling and heating unit)
6	Connecting cable(power cord)	13	Owner's manual, remote controller
7	Wall pipe		

⚠ Note:

- 1.Please contact the local agent for installation.
- 2.Don't use unqualified power cord.

8.3 Selection of Installation Location

1. Basic Requirement:

Installing the unit in the following places may cause malfunction. If it is unavoidable, please consult the local dealer:

- (1) The place with strong heat sources, vapors, flammable or explosive gas, or volatile objects spread in the air.
- (2) The place with high-frequency devices (such as welding machine, medical equipment).
- (3) The place near coast area.
- (4) The place with oil or fumes in the air.
- (5) The place with sulfureted gas.
- (6) Other places with special circumstances.

2. Indoor Unit:

- (1) There should be no obstruction near air inlet and air outlet.
- (2) Select a location where the condensation water can be dispersed easily and won't affect other people.
- (3) Select a location which is convenient to connect the outdoor unit and near the power socket.
- (4) Select a location which is out of reach for children.
- (5) The location should be able to withstand the weight of indoor unit and won't increase noise and vibration.
- (6) The appliance must be installed 250 cm above floor.
- (7) Don't install the indoor unit right above the electric appliance.
- (8) The appliance shall not be installed in the laundry.

3. Outdoor Unit:

- (1) Select a location where the noise and outflow air emitted by the outdoor unit will not affect neighborhood.
- (2) The location should be well ventilated and dry, in which the outdoor unit won't be exposed directly to sunlight or strong wind.
- (3) The location should be able to withstand the weight of outdoor unit.
- (4) Make sure that the installation follows the requirement of installation dimension diagram.
- (5) Select a location which is out of reach for children and far away from animals or plants.If it is unavoidable, please add fence for safety purpose.

8.4 Electric Connection Requirement

1. Safety Precaution

- (1) Must follow the electric safety regulations when installing the unit.
- (2) According to the local safety regulations, use qualified power supply circuit and air switch.
- (3) Make sure the power supply matches with the requirement of air conditioner. Unstable power supply or incorrect wiring may result in electric shock, fire hazard or malfunction. Please install proper power supply cables before using the air conditioner.

Air-conditioner	Air switch capacity
09K/12K/18K	16A

- (4) Properly connect the live wire, neutral wire and grounding wire of power socket.
- (5) Be sure to cut off the power supply before proceeding any work related to electricity and safety.
- (6) Do not put through the power before finishing installation.
- (7) For appliances with type Y attachment,the instructions shall contain the substance of the following.If the supply cord is damaged,it must be replaced by the manufacturer,its service agent or similarly qualified persons in order to avoid a hazard.
- (8) The temperature of refrigerant circuit will be high, please keep the interconnection cable away from the copper tube.

2. Grounding Requirement:

- (1) The air conditioner is first class electric appliance. It must be properly grounding with specialized grounding device by a professional. Please make sure it is always grounded effectively, otherwise it may cause electric shock.
- (2) The yellow-green wire in air conditioner is grounding wire, which can't be used for other purposes.
- (3) The grounding resistance should comply with national electric safety regulations.
- (4) The appliance must be positioned so that the plug is accessible.
- (5) An all-pole disconnection switch having a contact separation of at least 3mm in all poles should be connected in fixed wiring.
- (6) Including an air switch with suitable capacity, please note the following table. Air switch should be included magnet buckle and heating buckle function, it can protect the circuit-short and overload. (Caution: please do not use the fuse only for protect the circuit)

8.5 Installation of Indoor Unit

1. Choosing Installation location

Recommend the installation location to the client and then confirm it with the client.

2. Install Wall-mounting Frame

- (1) Hang the wall-mounting frame on the wall; adjust it in horizontal position with the level meter and then point out the screw fixing holes on the wall.
- (2) Drill the screw fixing holes on the wall with impact drill (the specification of drill head should be the same as the plastic expansion particle) and then fill the plastic expansion particles in the holes.

(3) Fix the wall-mounting frame on the wall with tapping screws (ST4.2X25TA) and then check if the frame is firmly installed by pulling the frame. If the plastic expansion particle is loose, please drill another fixing hole nearby.

3. Install Wall-mounting Frame

(1) Choose the position of piping hole according to the direction of outlet pipe. The position of piping hole should be a little lower than the wall-mounted frame. (As show in Fig.1)

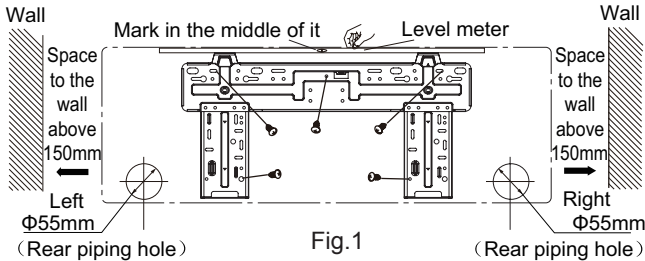

(2) Open a piping hole with the diameter of Φ55mm on the selected outlet pipe position. In order to drain smoothly, slant the piping hole on the wall slightly downward to the outdoor side with the gradient of 5-10°. (As show in Fig.2)

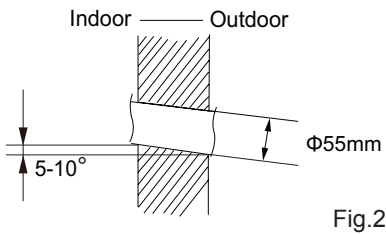

⚠ Note:

- (1) Pay attention to dust prevention and take relevant safety measures when opening the hole.
- (2) The plastic expansion particles are not provided and should be bought locally.

4. Outlet Pipe

(1) The pipe can be led out in the direction of right, rear right, left or rear left. (As show in Fig.3)

(2) When selecting leading out the pipe from left or right, please cut off the corresponding hole on the bottom case. (As show in Fig.4)

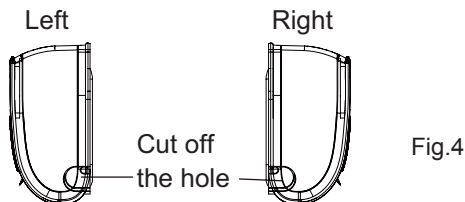
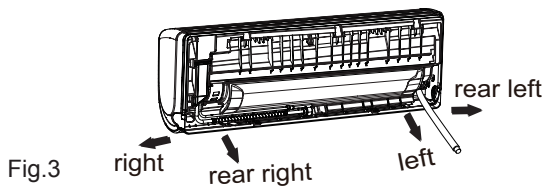

5. Connect the Pipe of Indoor Unit

- (1) Aim the pipe joint at the corresponding bellmouth. (As show in Fig.5)
- (2) Pretightening the union nut with hand.
- (3) Adjust the torque force by referring to the following sheet. Place the open-end wrench on the pipe joint and place the torque wrench on the union nut. Tighten the union nut with torque wrench. (As show in Fig.6)
- (4) Wrap the indoor pipe and joint of connection pipe with insulating pipe, and then wrap it with tape. (As show in Fig.7)

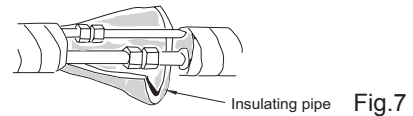
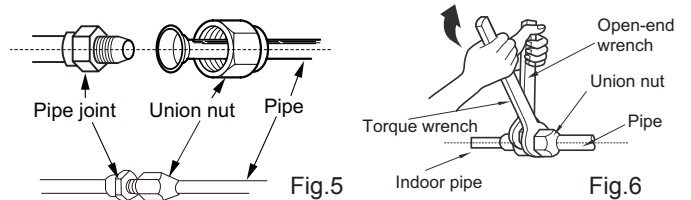

Refer to the following table for wrench moment of force:

Hex nut diameter(mm)	Tightening torque(N·m)
Φ6	15~20
Φ9.52	30~40
Φ12	45~55
Φ16	60~65
Φ19	70~75

6. Install Drain Hose

- (1) Connect the drain hose to the outlet pipe of indoor unit. (As show in Fig.8)
- (2) Bind the joint with tape. (As show in Fig.9)

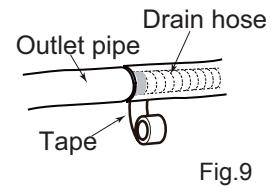
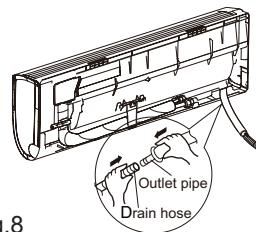

Fig.8

Fig.9

⚠ Note:

- (1) Add insulating pipe in the indoor drain hose in order to prevent condensation.
- (2) The plastic expansion particles are not provided. (As show in Fig.10)

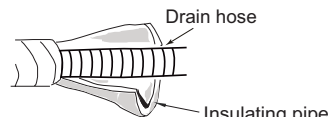
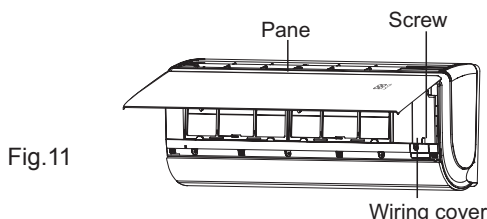

Fig.10

7. Connect Wire of Indoor Unit

(1) Open the panel, remove the screw on the wiring cover and then take down the cover.(As show in Fig.11)



(2) Make the power connection wire go through the cable-cross hole at the back of indoor unit and then pull it out from the front side.(As show in Fig.12)

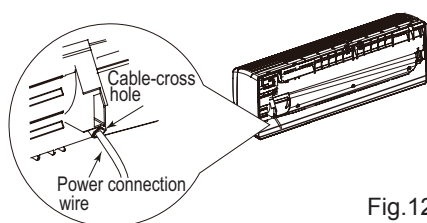

(3) Remove the wire clip; connect the power connection wire to the wiring terminal according to the color; tighten the screw and then fix the power connection wire with wire clip.After finishing wiring of 18K unit, clamp the grounding wire (yellow-green wire) into the wire-crossing groove(As show in Fig.13), in order to avoid pressing the wire when closing the electric box cover.(As show in Fig.13)

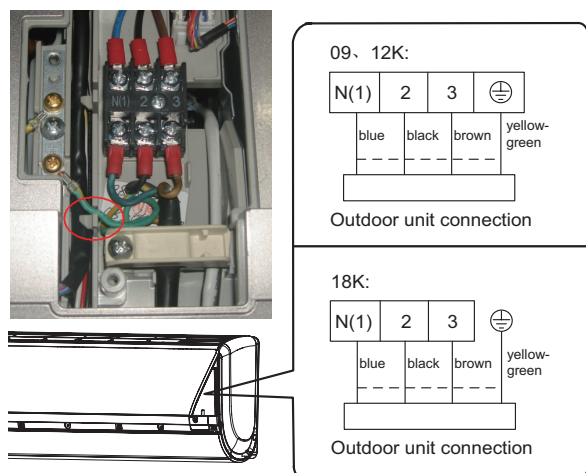

Fig.13

4.Put wiring cover back and then tighten the screw.
5.Close the panel.

⚠ Note:

- (1) All wires of indoor unit and outdoor unit should be connected by a professional.
- (2) If the length of power connection wire is insufficient, please contact the supplier for a new one. Avoid extending the wire by yourself.
- (3) For the air conditioner with plug, the plug should be reachable after finishing installation.
- (4) For the air conditioner without plug, an air switch must be installed in the line. The air switch should be all-pole parting and the contact parting distance should be more than 3mm.

8. Bind up Pipe

- (1) Bind up the connection pipe, power cord and drain hose with the band.(As show in Fig.14)
- (2) Reserve a certain length of drain hose and power cord for installation when binding them. When binding to a certain degree, separate the indoor power and then separate the drain hose.(As show in Fig.15)
- (3) Bind them evenly.
- (4) The liquid pipe and gas pipe should be bound separately at the end.

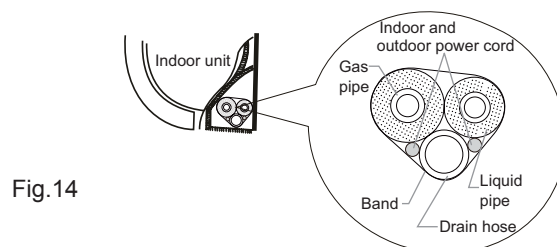

Fig.14

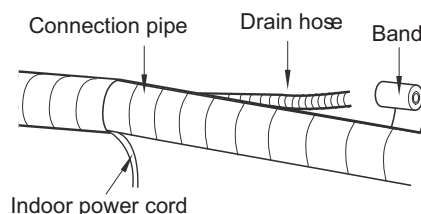

Fig.15

⚠ Note:

- (1) The power cord and control wire can't be crossed or winding.
- (2) The drain hose should be bound at the bottom.

9. Hang the Indoor Unit

- (1) Put the bound pipes in the wall pipe and then make them pass through the wall hole.
- (2) Hang the indoor unit on the wall-mounting frame.
- (3) Stuff the gap between pipes and wall hole with sealing gum.
- (4) Fix the wall pipe.(As show in Fig.16)
- (5) Check if the indoor unit is installed firmly and closed to the wall.(As show in Fig.17)

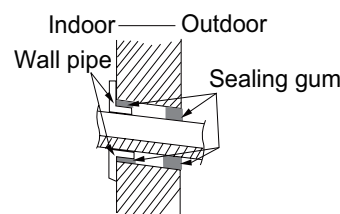

Fig.16

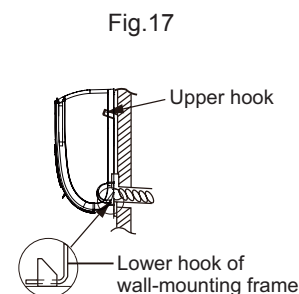

Fig.17

⚠ Note:

Do not bend the drain hose too excessively in order to prevent blocking.

8.6 Installation of Outdoor Unit

1. Fix the Support of Outdoor Unit(Select it according to the actual installation situation)

- (1) Select installation location according to the house structure.
- (2) Fix the support of outdoor unit on the selected location with expansion screws.

⚠ Note:

- (1) Take sufficient protective measures when installing the outdoor unit.
- (2) Make sure the support can withstand at least four times the unit weight.
- (3) The outdoor unit should be installed at least 3cm above the floor in order to install drain joint.(As show in Fig.18)
- (4) For the unit with cooling capacity of 2300W~5000W, 6 expansion screws are needed; for the unit with cooling capacity of 6000W~8000W, 8 expansion screws are needed; for the unit with cooling capacity of 10000W~16000W, 10 expansion screws are needed.

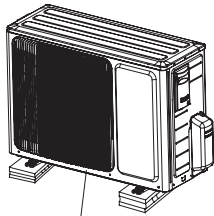

At least 3cm above the floor

Fig.18

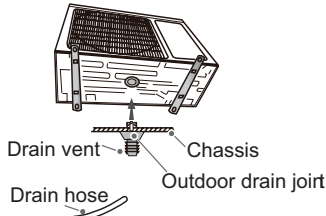

Fig.19

2. Install Drain Joint(Only for cooling and heating unit)

- (1) Connect the outdoor drain joint into the hole on the chassis.
 - (2) Connect the drain hose into the drain vent.
- (As show in Fig.19)

3. Fix Outdoor Unit

- (1) Place the outdoor unit on the support.
 - (2) Fix the foot holes of outdoor unit with bolts.
- (As show in Fig.20)

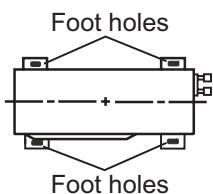

Fig.20

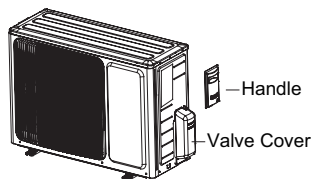

Fig.21

4. Connect Indoor and Outdoor Pipes

- (1) Remove the screw on the right handle and valve cover of outdoor unit and then remove the handle and valve cover.(As show in Fig.21)
- (2) Remove the screw cap of valve and aim the pipe joint at the bellmouth of pipe.(As show in Fig.22)

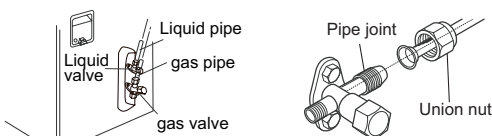

Fig.22

- (3) Pretightening the union nut with hand.
- (4) Tighten the union nut with torque wrench .

Refer to the following table for wrench moment of force:

Hex nut diameter(mm)	Tightening torque(N·m)
Φ6	15~20
Φ9.52	30~40
Φ12	45~55
Φ16	60~65
Φ19	70~75

5. Connect Outdoor Electric Wire

- (1) Remove the wire clip; connect the power connection wire and power cord to the wiring terminal according to the color ; fix the them with screws.(As show in Fig.23)

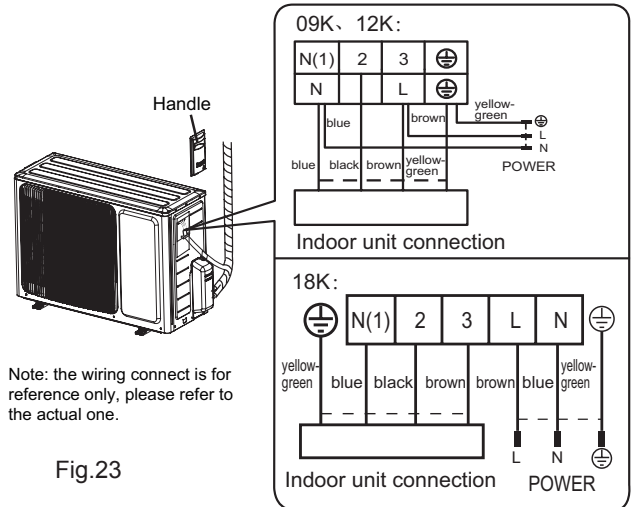

Fig.23

- (2) Fix the power connection wire and power cord with wire clip.

⚠ Note:

- (1) After tightening the screw, pull the power cord slightly to check if it is firm.
- (2) Never cut the power connection wire to prolong or shorten the distance.

6. Neaten the Pipes

- (1) The pipes should be placed along the wall, bent reasonably and hidden possibly. Min. semidiameter of bending the pipe is 10cm.
- (2) If the outdoor unit is higher than the wall hole, you must set a U-shaped curve in the pipe before pipe goes into the room, in order to prevent rain from getting into the room.(As show in Fig.24)

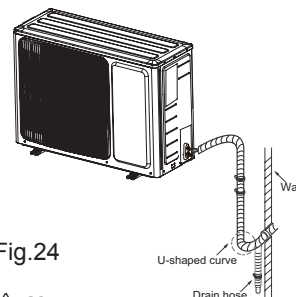

Fig.24

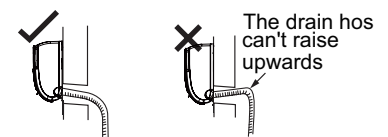
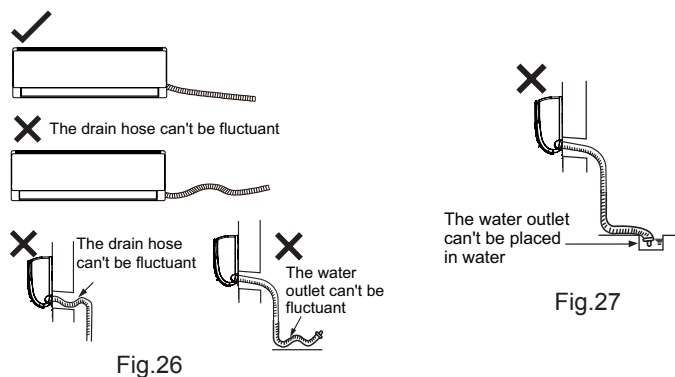

Fig.25

⚠ Note:

- (1) The through-wall height of drain hose shouldn't be higher than the outlet pipe hole of indoor unit.(As show in Fig.25)
- (2) Slant the drain hose slightly downwards. The drain hose can't be curved, raised and fluctuant, etc.(As show in Fig.26)

(3) The water outlet can't be placed in water in order to drain smoothly.(As show in Fig.27)



8.7 Vacuum Pumping and Leak Detection

1. Use Vacuum Pump

- (1) Remove the valve caps on the liquid valve and gas valve and the nut of refrigerant charging vent.
- (2) Connect the charging hose of piezometer to the refrigerant charging vent of gas valve and then connect the other charging hose to the vacuum pump.
- (3) Open the piezometer completely and operate for 10-15min to check if the pressure of piezometer remains in -0.1MPa.
- (4) Close the vacuum pump and maintain this status for 1-2min to check if the pressure of piezometer remains in -0.1MPa. If the pressure decreases, there may be leakage.
- (5) Remove the piezometer, open the valve core of liquid valve and gas valve completely with inner hexagon spanner.
- (6) Tighten the screw caps of valves and refrigerant charging vent.(As show in Fig.28)

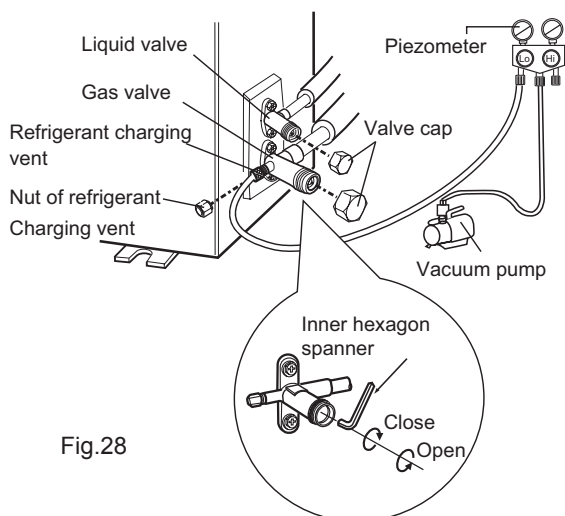

8.8 Check after Installation and Test Operation

1. Check after Installation

Check according to the following requirement after finishing installation.

NO.	Items to be checked	Possible malfunction
1	Has the unit been installed firmly?	The unit may drop, shake or emit noise.
2	Have you done the refrigerant leakage test?	It may cause insufficient cooling (heating) capacity.
3	Is heat insulation of pipeline sufficient?	It may cause condensation and water dripping.
4	Is water drained well?	It may cause condensation and water dripping.
5	Is the voltage of power supply according to the voltage marked on the nameplate?	It may cause malfunction or damage the parts.
6	Is electric wiring and pipeline installed correctly?	It may cause malfunction or damage the parts.
7	Is the unit grounded securely?	It may cause electric leakage.
8	Does the power cord follow the specification?	It may cause malfunction or damage the parts.
9	Is there any obstruction in air inlet and air outlet?	It may cause insufficient cooling (heating).
10	The dust and sundries caused during installation are removed?	It may cause malfunction or damaging the parts.
11	The gas valve and liquid valve of connection pipe are open completely?	It may cause insufficient cooling (heating) capacity.

2. Test Operation

- (1) Preparation of test operation
 - The client approves the air conditioner installation.
 - Specify the important notes for air conditioner to the client.
- (2) Method of test operation
 - Put through the power, press ON/OFF button on the remote controller to start operation.
 - Press MODE button to select AUTO, COOL, DRY, FAN and HEAT to check whether the operation is normal or not.
 - If the ambient temperature is lower than 16°C , the air conditioner can't start cooling.

2. Leakage Detection

- (1) With leakage detector:
Check if there is leakage with leakage detector.
- (2) With soap water:
If leakage detector is not available, please use soap water for leakage detection. Apply soap water at the suspected position and keep the soap water for more than 3min. If there are air bubbles coming out of this position, there's a leakage.

9. Maintenance

9.1 Error Code List

No.	Malfunction Name	Display Method of Indoor Unit			Display Method of Outdoor Unit			A/C status	Possible Causes	
		Dual-8 Code Display	Indicator Display (during blinking, ON 0.5s and OFF 0.5s)			Indicator has 3 kinds of display status and during blinking, ON 0.5s and OFF 0.5s				
			Operation Indicator	Cool Indicator	Heating Indicator	Yellow Indicator	Red Indicator	Green Indicator		
1	High pressure protection of system	E1							During cooling and drying operation, except indoor fan operates, all loads stop operation. During heating operation, the complete unit stops.	Possible reasons: 1. Refrigerant was superabundant; 2. Poor heat exchange (including filth blockage of heat exchanger and bad radiating environment); Ambient temperature is too high.
2	Antifreezing protection	E2				OFF 3S and blink 3 times			During cooling and drying operation, compressor and outdoor fan stop while indoor fan operates.	1. Poor air-return in indoor unit; 2. Fan speed is abnormal; 3. Evaporator is dirty.
3	Low pressure protection of system	E3					OFF 3S and blink 9 times		The Dual-8 Code Display will show E3 until the low pressure switch stop operation.	1.Low-pressure protection 2.Low-pressure protection of system 3.Low-pressure protection of compressor
4	High discharge temperature protection of compressor	E4				OFF 3S and blink 7 times			During cooling and drying operation, compressor and outdoor fan stop while indoor fan operates. During heating operation, all loads stop.	Please refer to the malfunction analysis (discharge protection, overload).
5	Overcurrent protection	E5				OFF 3S and blink 5 times			During cooling and drying operation, compressor and outdoor fan stop while indoor fan operates. During heating operation, all loads stop.	1. Supply voltage is unstable; 2. Supply voltage is too low and load is too high; 3. Evaporator is dirty.
6	Communication Malfunction	E6						OFF	During cooling operation, compressor stops while indoor fan motor operates. During heating operation, the complete unit stops.	Refer to the corresponding malfunction analysis.
7	High temperature resistant protection	E8				OFF 3S and blink 6 times			During cooling operation: compressor will stop while indoor fan will operate. During heating operation, the complete unit stops.	Refer to the malfunction analysis (overload, high temperature resistant).
8	EEPROM malfunction	EE				OFF 3S and blink 11 times			During cooling and drying operation, compressor will stop while indoor fan will operate; During heating operation, the complete unit will stop	Replace outdoor control panel AP1
9	Limit/decrease frequency due to high temperature of module	EU							All loads operate normally, while operation frequency for compressor is decreased	Discharging after the complete unit is de-energized for 20mins, check whether the thermal grease on IPM Module of outdoor control panel AP1 is sufficient and whether the radiator is inserted tightly. If its no use, please replace control panel AP1.
10	Malfunction protection of jumper cap	C5							Wireless remote receiver and button are effective, but can not dispose the related command	1. No jumper cap insert on mainboard. 2. Incorrect insert of jumper cap. 3. Jumper cap damaged. 4. Abnormal detecting circuit of mainboard.

No.	Malfunction Name	Display Method of Indoor Unit			Display Method of Outdoor Unit			A/C status	Possible Causes	
		Dual-8 Code Display	Indicator Display (during blinking, ON 0.5s and OFF 0.5s)			Indicator has 3 kinds of display status and during blinking, ON 0.5s and OFF 0.5s				
			Operation Indicator	Cool Indicator	Heating Indicator	Yellow Indicator	Red Indicator			Green Indicator
11	Gathering refrigerant	F0							When the outdoor unit receive signal of Gathering refrigerant ,the system will be forced to run under cooling mode for gathering refrigerant	Nominal cooling mode
12	Indoor ambient temperature sensor is open/short circuited	F1							During cooling and drying operation, indoor unit operates while other loads will stop; during heating operation, the complete unit will stop operation.	<ol style="list-style-type: none"> 1. Loosening or bad contact of indoor ambient temp. sensor and mainboard terminal. 2. Components in mainboard fell down leads short circuit. 3. Indoor ambient temp. sensor damaged.(check with sensor resistance value chart) 4. Mainboard damaged.
13	Indoor evaporator temperature sensor is open/short circuited	F2							AC stops operation once reaches the setting temperature. Cooling, drying: internal fan motor stops operation while other loads stop operation; heating: AC stop operation	<ol style="list-style-type: none"> 1. Loosening or bad contact of Indoor evaporator temp. sensor and mainboard terminal. 2. Components on the mainboard fall down leads short circuit. 3. Indoor evaporator temp. sensor damaged.(check temp. sensor value chart for testing) 4. Mainboard damaged.
14	Outdoor ambient temperature sensor is open/short circuited	F3					OFF 3S and blink 6 times		During cooling and drying operating, compressor stops while indoor fan operates; During heating operation, the complete unit will stop operation	Outdoor temperature sensor hasnt been connected well or is damaged. Please check it by referring to the resistance table for temperature sensor)
15	Outdoor condenser temperature sensor is open/short circuited	F4					OFF 3S and blink 5 times		During cooling and drying operation, compressor stops while indoor fan will operate; During heating operation, the complete unit will stop operation.	Outdoor temperature sensor hasnt been connected well or is damaged. Please check it by referring to the resistance table for temperature sensor)
16	Outdoor discharge temperature sensor is open/short circuited	F5					OFF 3S and blink 7 times		During cooling and drying operation, compressor will sop after operating for about 3 mins, while indoor fan will operate; During heating operation, the complete unit will stop after operating for about 3 mins.	<ol style="list-style-type: none"> 1.Outdoor temperature sensor hasnt been connected well or is damaged. Please check it by referring to the resistance table for temperature sensor) 2.The head of temperature sensor hasnt been inserted into the copper tube
17	Limit/ decrease frequency due to overload	F6					OFF 3S and blink 3 times		All loads operate normally, while operation frequency for compressor is decreased	Refer to the malfunction analysis (overload, high temperature resistant)
18	Decrease frequency due to overcurrent	F8					OFF 3S and blink once		All loads operate normally, while operation frequency for compressor is decreased	The input supply voltage is too low; System pressure is too high and overload

No.	Malfunction Name	Display Method of Indoor Unit			Display Method of Outdoor Unit			A/C status	Possible Causes	
		Dual-8 Code Display	Indicator Display (during blinking, ON 0.5s and OFF 0.5s)			Indicator has 3 kinds of display status and during blinking, ON 0.5s and OFF 0.5s				
			Operation Indicator	Cool Indicator	Heating Indicator	Yellow Indicator	Red Indicator			Green Indicator
19	Decrease frequency due to high air discharge	F9					OFF 3S and blink twice	All loads operate normally, while operation frequency for compressor is decreased	Overload or temperature is too high; Refrigerant is insufficient; Malfunction of electric expansion valve (EKV)	
20	Limit/ decrease frequency due to antifreezing	FH					OFF 3S and blink 4 times	All loads operate normally, while operation frequency for compressor is decreased	Poor air-return in indoor unit or fan speed is too low	
21	Voltage for DC bus-bar is too high	PH					OFF 3S and blink 13 times	During cooling and drying operation, compressor will stop while indoor fan will operate; During heating operation, the complete unit will stop operation.	1. Measure the voltage of position L and N on wiring board (XT), if the voltage is higher than 265VAC, turn on the unit after the supply voltage is increased to the normal range. 2.If the AC input is normal, measure the voltage of electrolytic capacitor C on control panel (AP1), if its normal, theres malfunction for the circuit, please replace the control panel (AP1)	
22	Voltage of DC bus-bar is too low	PL					OFF 3S and blink 12 times	During cooling and drying operation, compressor will stop while indoor fan will operate; During heating operation, the complete unit will stop	1. Measure the voltage of position L and N on wiring board (XT), if the voltage is higher than 150VAC, turn on the unit after the supply voltage is increased to the normal range. 2.If the AC input is normal, measure the voltage of electrolytic capacitor C on control panel (AP1), if its normal, theres malfunction for the circuit, please replace the control panel (AP1)	
23	Compressor Min frequency in test state	P0							Showing during min. cooling or min. heating test	
24	Compressor rated frequency in test state	P1							Showing during nominal cooling or nominal heating test	
25	Compressor maximum frequency in test state	P2							Showing during max. cooling or max. heating test	

No.	Malfunction Name	Display Method of Indoor Unit			Display Method of Outdoor Unit			A/C status	Possible Causes	
		Dual-8 Code Display	Indicator Display (during blinking, ON 0.5s and OFF 0.5s)			Indicator has 3 kinds of display status and during blinking, ON 0.5s and OFF 0.5s				
			Operation Indicator	Cool Indicator	Heating Indicator	Yellow Indicator	Red Indicator			Green Indicator
26	Compressor intermediate frequency in test state	P3							Showing during middle cooling or middle heating test	
27	Overcurrent protection of phase current for compressor	P5						During cooling and drying operation, compressor will stop while indoor fan will operate; During heating operation, the complete unit will stop operation.	Refer to the malfunction analysis (IPM protection, loss of synchronism protection and overcurrent protection of phase current for compressor.	
28	Charging malfunction of capacitor	PU						During cooling and drying operation, compressor will stop while indoor fan will operate; During heating operation, the complete unit will stop	Refer to the part three—charging malfunction analysis of capacitor	
29	Malfunction of module temperature sensor circuit	P7						During cooling and drying operation, compressor will stop while indoor fan will operate; During heating operation, the complete unit will stop	Replace outdoor control panel AP1	
30	Module high temperature protection	P8						During cooling operation, compressor will stop while indoor fan will operate; During heating operation, the complete unit will stop	After the complete unit is de-energized for 20mins, check whether the thermal grease on IPM Module of outdoor control panel AP1 is sufficient and whether the radiator is inserted tightly. If its no use, please replace control panel AP1.	
31	Decrease frequency due to high temperature resistant during heating operation	H0						All loads operate normally, while operation frequency for compressor is decreased	Refer to the malfunction analysis (overload, high temperature resistant)	
32	Overload protection for compressor	H3				OFF 3S and blink 8 times		During cooling and drying operation, compressor will stop while indoor fan will operate; During heating operation, the complete unit will stop operation.	1. Wiring terminal OVC-COMP is loosened. In normal state, the resistance for this terminal should be less than 1ohm. 2.Refer to the malfunction analysis (discharge protection, overload)	
33	IPM protection	H5				OFF 3S and blink 4 times		During cooling and drying operation, compressor will stop while indoor fan will operate; During heating operation, the complete unit will stop operation.	Refer to the malfunction analysis (IPM protection, loss of synchronism protection and overcurrent protection of phase current for compressor.	
34	Module temperature is too high	H5				OFF 3S and blink 10 times				

No.	Malfunction Name	Display Method of Indoor Unit			Display Method of Outdoor Unit			A/C status	Possible Causes	
		Dual-8 Code Display	Indicator Display (during blinking, ON 0.5s and OFF 0.5s)			Indicator has 3 kinds of display status and during blinking, ON 0.5s and OFF 0.5s				
			Operation Indicator	Cool Indicator	Heating Indicator	Yellow Indicator	Red Indicator			Green Indicator
35	Internal motor (fan motor) do not operate	H6							Internal fan motor, external fan motor, compressor and electric heater stop operation,guide louver stops at present location.	1. Bad contact of DC motor feedback terminal. 2. Bad contact of DC motor control end. 3. Fan motor is stalling. 4. Motor malfunction. 5. Malfunction of mainboard rev detecting circuit.
36	System is abnormal	H4				OFF 1S and blink 6 times			During cooling and drying operation, compressor will stop while indoor fan will operate; During heating operation, the complete unit will stop operation.	Refer to the malfunction analysis (overload, high temperature resistant)
37	Static dedusting protection	H2								
38	Desynchronizing of compressor	H7							During cooling and drying operation, compressor will stop while indoor fan will operate; During heating operation, the complete unit will stop operation.	Refer to the malfunction analysis (IPM protection, loss of synchronism protection and overcurrent protection of phase current for compressor.
39	PFC protection	HC				OFF 3S and blink 14 times			During cooling and drying operation, compressor will stop while indoor fan will operate; During heating operation, the complete unit will stop operation.	Refer to the malfunction analysis
40	Outdoor DC fan motor malfunction	L3					OFF 3S and blink 14 times		Outdoor DC fan motor malfunction lead to compressor stop operation,	DC fan motor malfunction or system blocked or the connector loosed
41	power protection	L9				OFF 3S and blink 9 times			compressor stop operation and Outdoor fan motor will stop 30s latter , 3 minutes latter fan motor and compressor will restart	To protect the electrical components when detect high power
42	Indoor unit and outdoor unit doesnt match	LP				OFF 3S and blink 16 times			compressor and Outdoor fan motor cant work	Indoor unit and outdoor unit doesnt match
43	Failure start-up	LC							During cooling and drying operation, compressor will stop while indoor fan will operate; During heating operation, the complete unit will stop operation.	Refer to the malfunction analysis
44	Normal communication							continuously		
45	Defrosting				OFF 3S and blink once (during blinking, ON 10s and OFF 0.5s)	OFF 3S and blink twice			Defrosting will occur in heating mode. Compressor will operate while indoor fan will stop operation.	Its the normal state



No.	Malfunction Name	Display Method of Indoor Unit			Display Method of Outdoor Unit			A/C status	Possible Causes	
		Dual-8 Code Display	Indicator Display (during blinking, ON 0.5s and OFF 0.5s)			Indicator has 3 kinds of display status and during blinking, ON 0.5s and OFF 0.5s				
			Operation Indicator	Cool Indicator	Heating Indicator	Yellow Indicator	Red Indicator			Green Indicator
46	Malfunction of phase current detection circuit for compressor	U1							During cooling and drying operation, compressor will stop while indoor fan will operate; During heating operation, the complete unit will stop	Replace outdoor control panel AP1
47	Malfunction of voltage dropping for DC bus-bar	U3							During cooling and drying operation, compressor will stop while indoor fan will operate; During heating operation, the complete unit will stop	Supply voltage is unstable
48	Malfunction of complete units current detection	U5							During cooling and drying operation, the compressor will stop while indoor fan will operate; During heating operating, the complete unit will stop operation.	Theres circuit malfunction on outdoor units control panel AP1, please replace the outdoor units control panel AP1.
49	The four-way valve is abnormal	U7							If this malfunction occurs during heating operation, the complete unit will stop operation.	1. Supply voltage is lower than AC175V; 2. Wiring terminal 4V is loosened or broken; 3. 4V is damaged, please replace 4V.
50	Frequency limiting (power)						OFF 3S and blink 13 times			
51	Compressor is open-circuited						OFF 3S and blink once			
52	The temperature for turning on the unit is reached						OFF 3S and blink 8 times			
53	Frequency limiting (module temperature)						OFF 3S and blink 11 times			
54	Malfunction of zero-cross detection circuit	U8							The complete unit stops	1. Power supply is abnormal; 2. Detection circuit of indoor control mainboard is abnormal.
54	Zerocrossing malfunction of outdoor unit	U9							During cooling operation, compressor will stop while indoor fan will operate; during heating, the complete unit will stop operation.	Replace outdoor control panel AP1

9.2 Procedure of Troubleshooting

Indoor Unit

1. Malfunction of Temperature Sensor F1, F2

Main detection points:

- Is the wiring terminal between the temperature sensor and the controller loosened or poorly contacted?
- Is there short circuit due to trip-over of the parts?
- Is the temperature sensor broken?
- Is mainboard broken?

Malfunction diagnosis process:

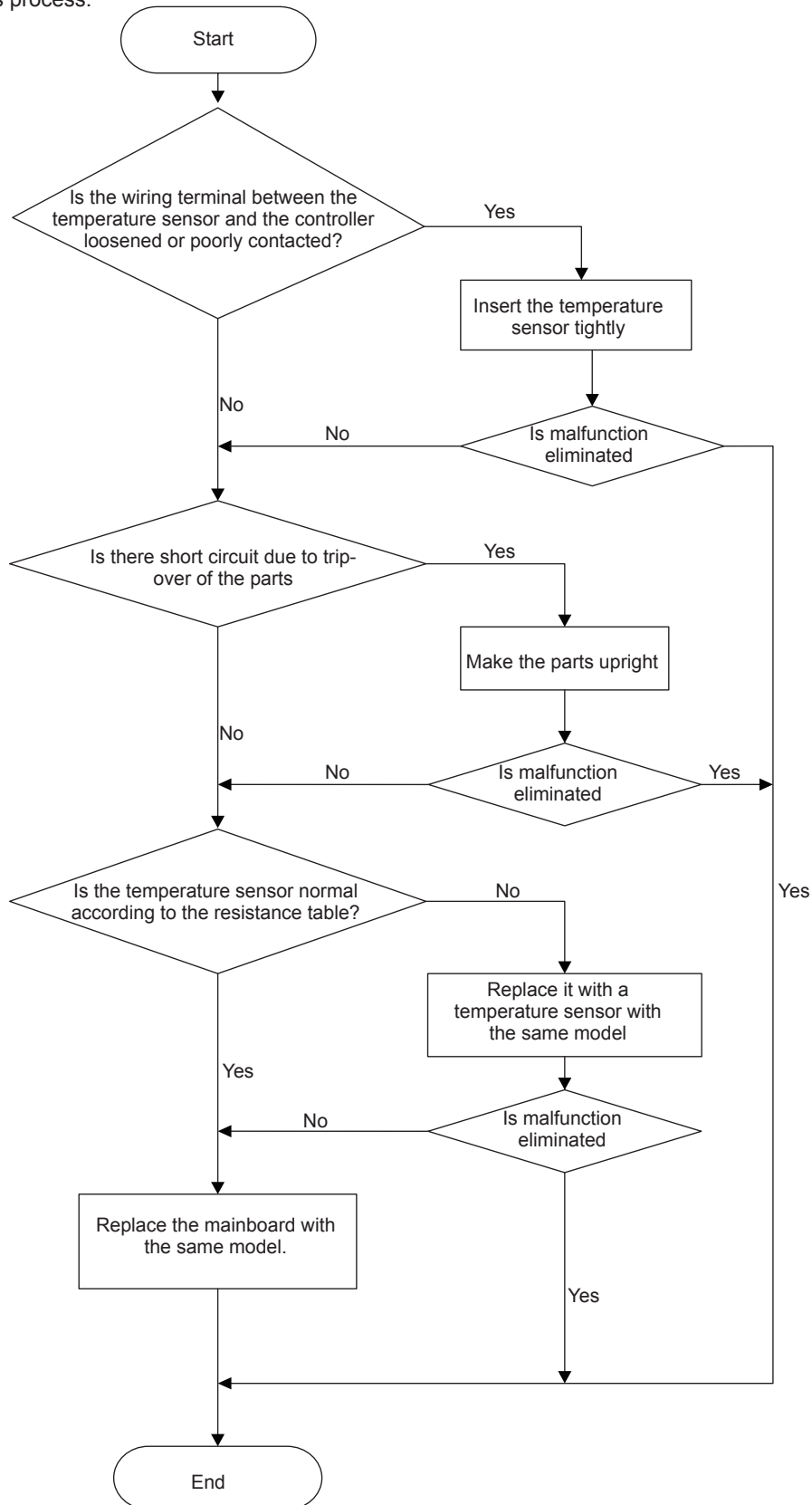

2. Malfunction of Blocked Protection of IDU Fan Motor H6

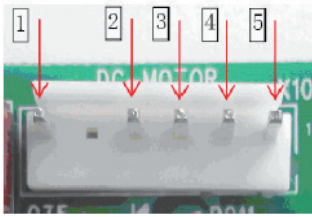
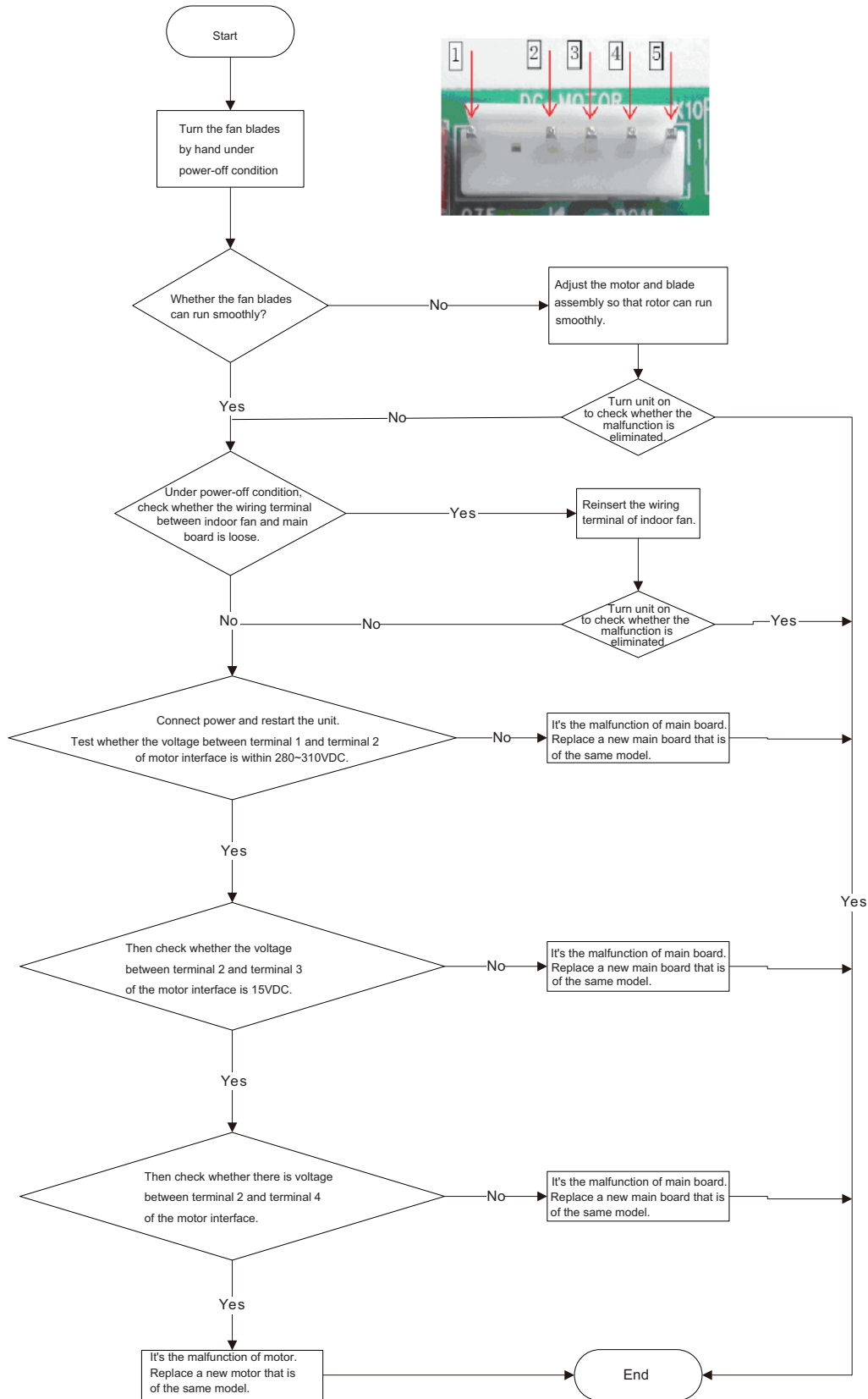

4. Communication Malfunction E6

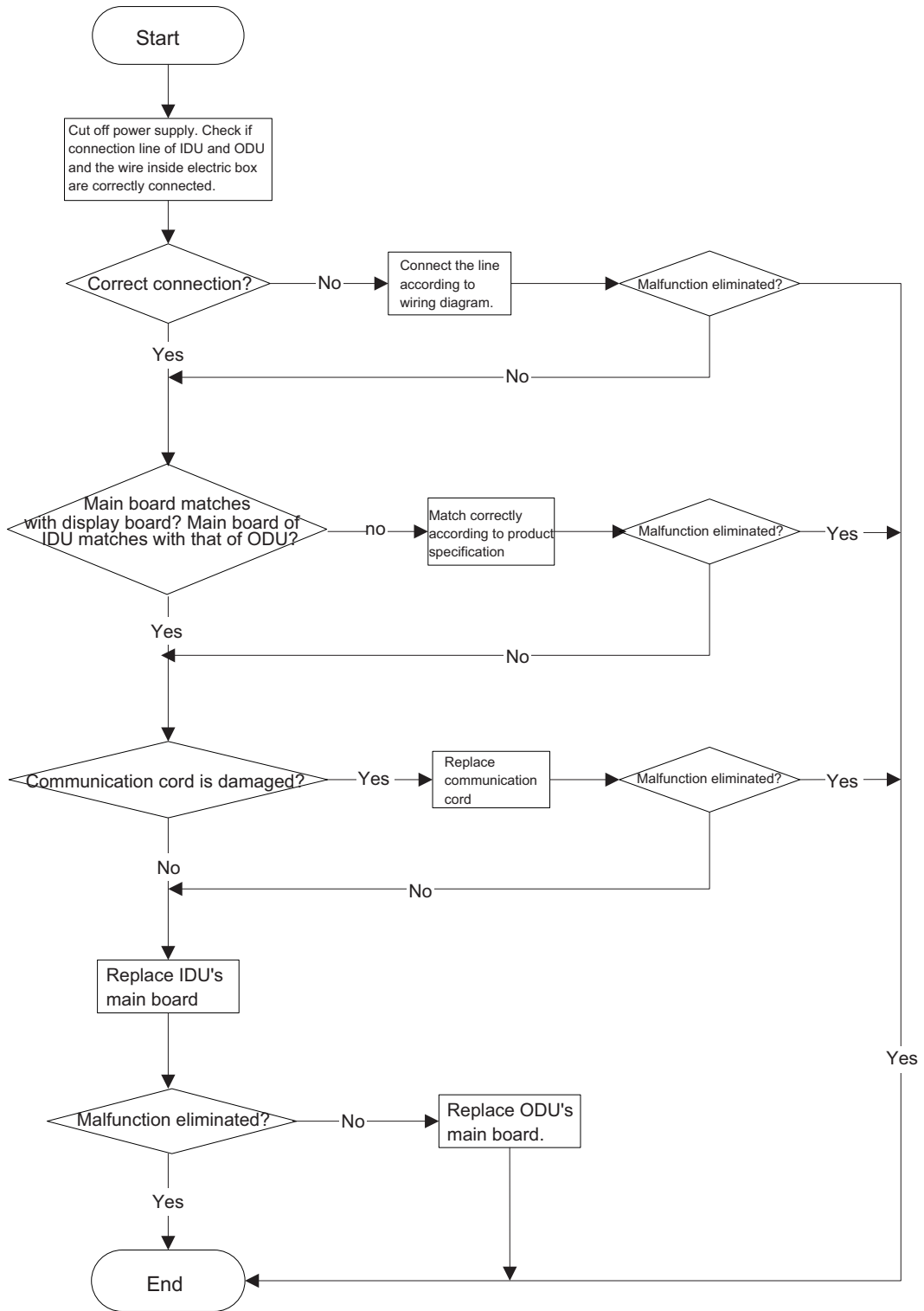

2. IPM protection(H5), desynchronizing malfunction(H7), overcurrent of compressor phase current (P5) (AP1 below means control board of outdoor unit)

Main detection points:

- Is voltage input within the normal range
- If the control board AP1 is well connected with compressor COMP? If they are loosened? If the connection sequence is correct?
- Heat exchange of unit is not good (heat exchanger is dirty and unit radiating environment is bad);
- If the system pressure is too high?
- If the refrigerant charging amount is appropriate?
- If coil resistance of compressor is normal? Is compressor coil insulating to copper pipe well?
- If the work load of unit is heavy? If radiating of unit is good?

Malfunction diagnosis process:

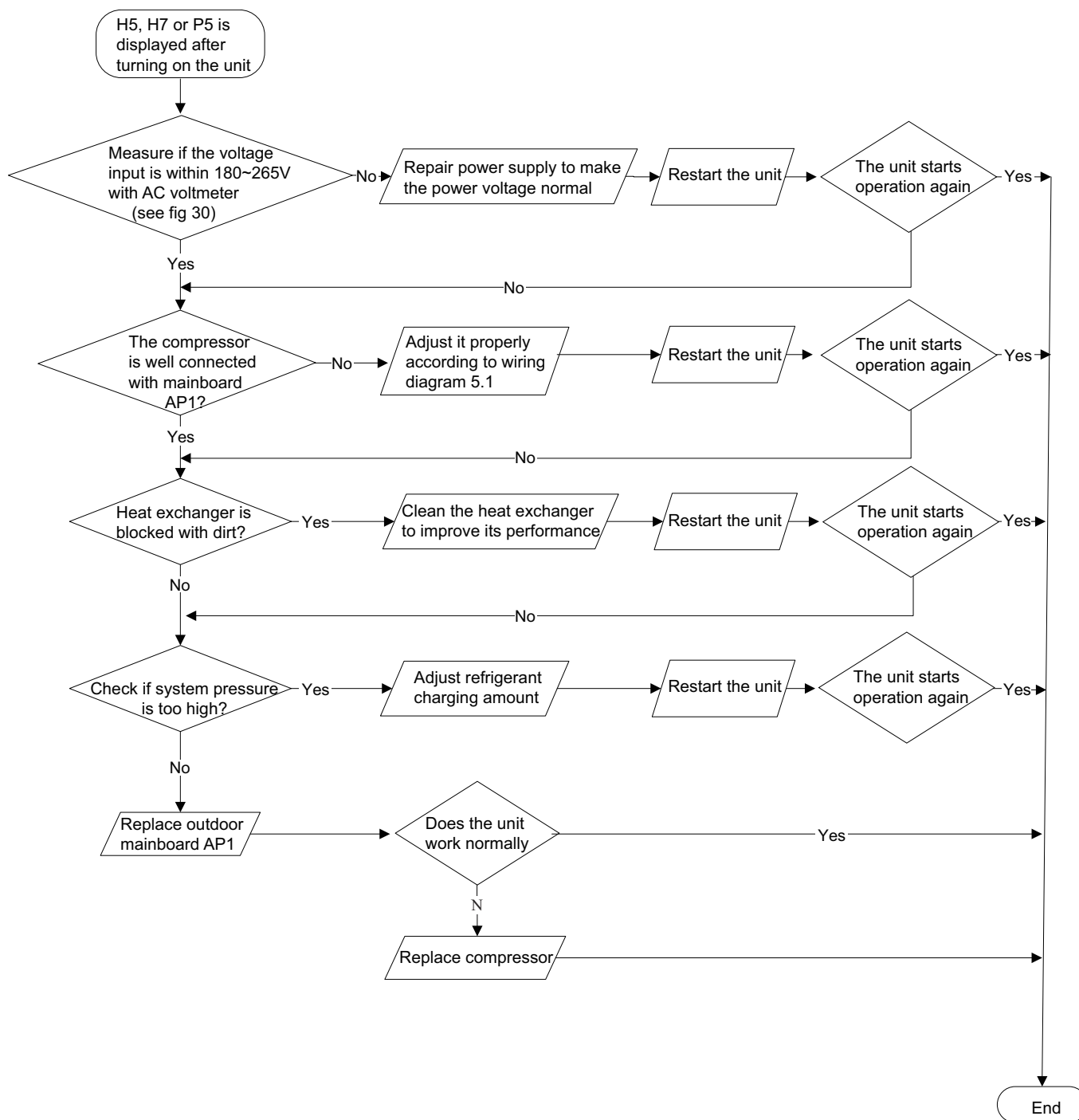

4. Start-up failure (LC) (AP1 below means control board of outdoor unit)

Main detection points:

- If the compressor wiring is correct?
- If the stop time of compressor is sufficient?
- If the compressor is damaged?
- If the refrigerant charging amount is too much?

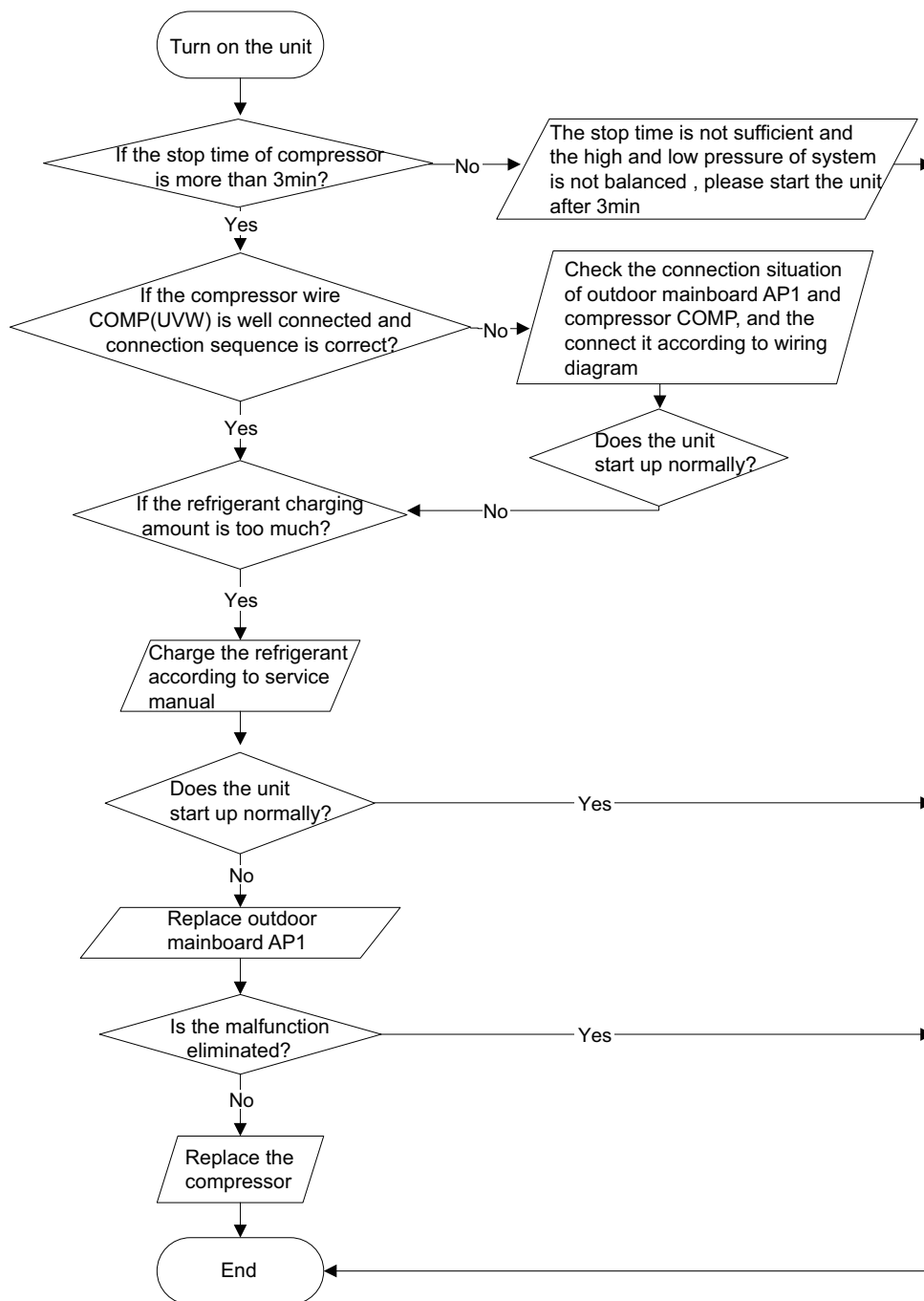

5. Overload and high discharge temperature malfunction

Main detection points:

- If the electronic expansion valve is connected well? Is the electronic expansion valve damaged?
- If the refrigerant is leaked?
- The compressor overload protection terminal is not connected well with the mainboard?
- If the overload protector is damaged?
- Heat exchange of unit is not good? (heat exchanger is dirty and unit radiating environment is bad)
- Too much load of the system causes high temperature of compressor after working for a long time?
- Malfunction of discharge temperature sensor?

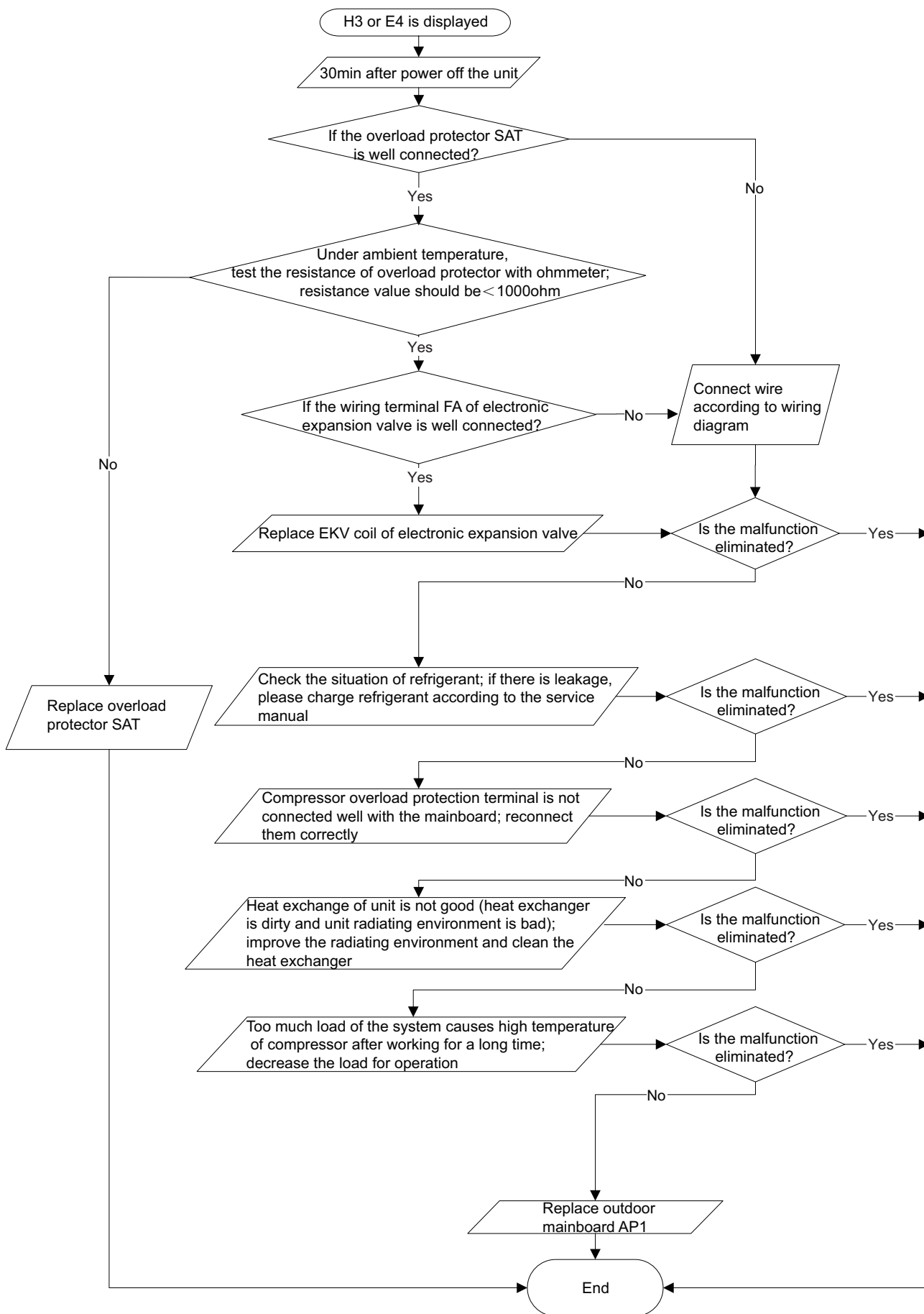

7. Communication malfunction (E6)

Main detection points:

- Check if the connection wire and the built-in wiring of indoor and outdoor unit are connected well and without damage;
- If the communication circuit of indoor mainboard is damaged? If the communication circuit of outdoor mainboard (AP1) is damaged?

Malfunction diagnosis process:

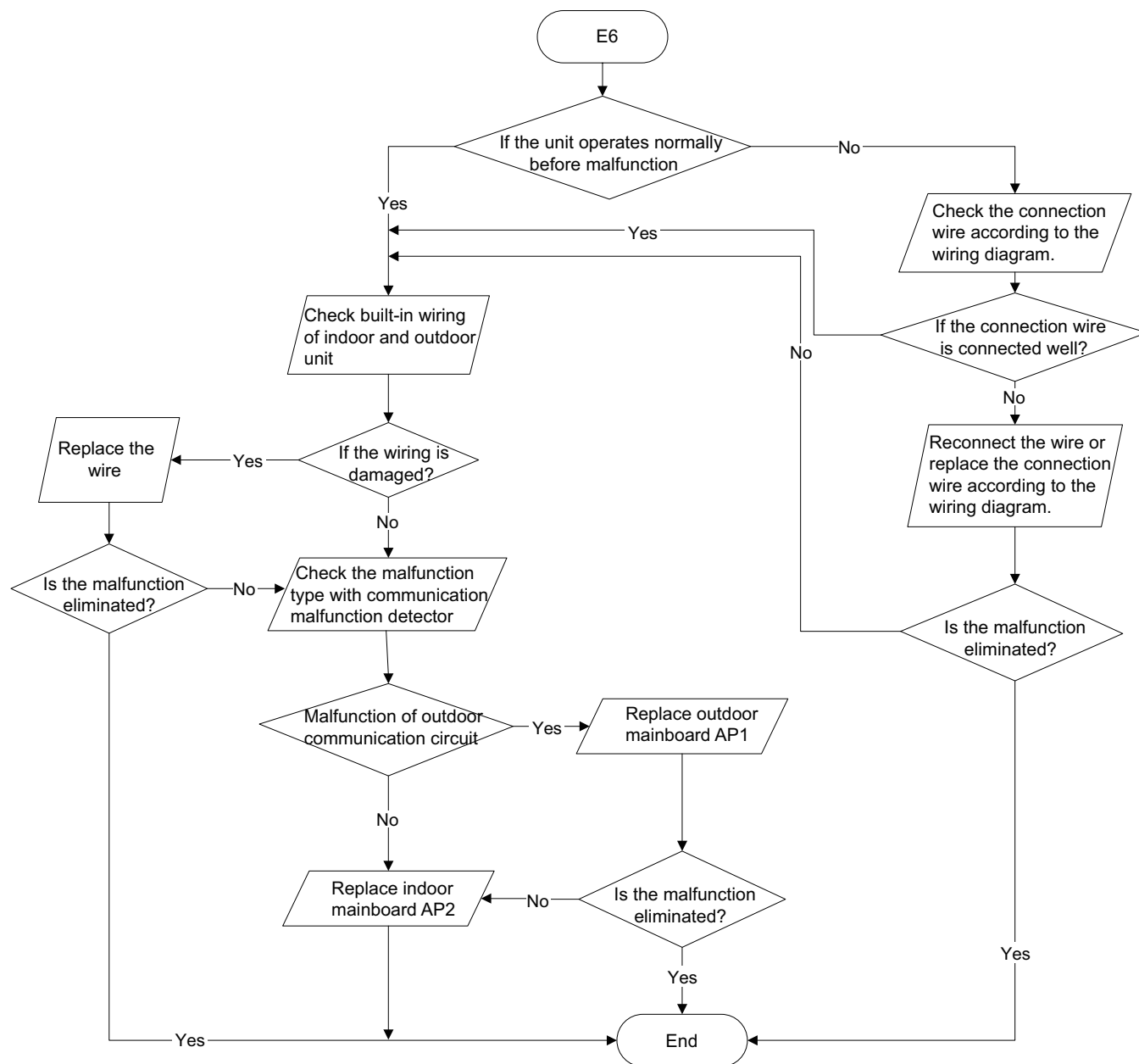

2. Capacity charging malfunction (outdoor unit malfunction) (AP1 below is control board of outdoor unit)

Main detection point:

- Detect if the voltage of L and N terminal of wiring board is between 210VAC-240VAC by alternating voltage meter;
- Is reactor (L) well connected? Is connection wire loosened or pull-out? Is reactor (L) damaged?

Malfunction diagnosis process:

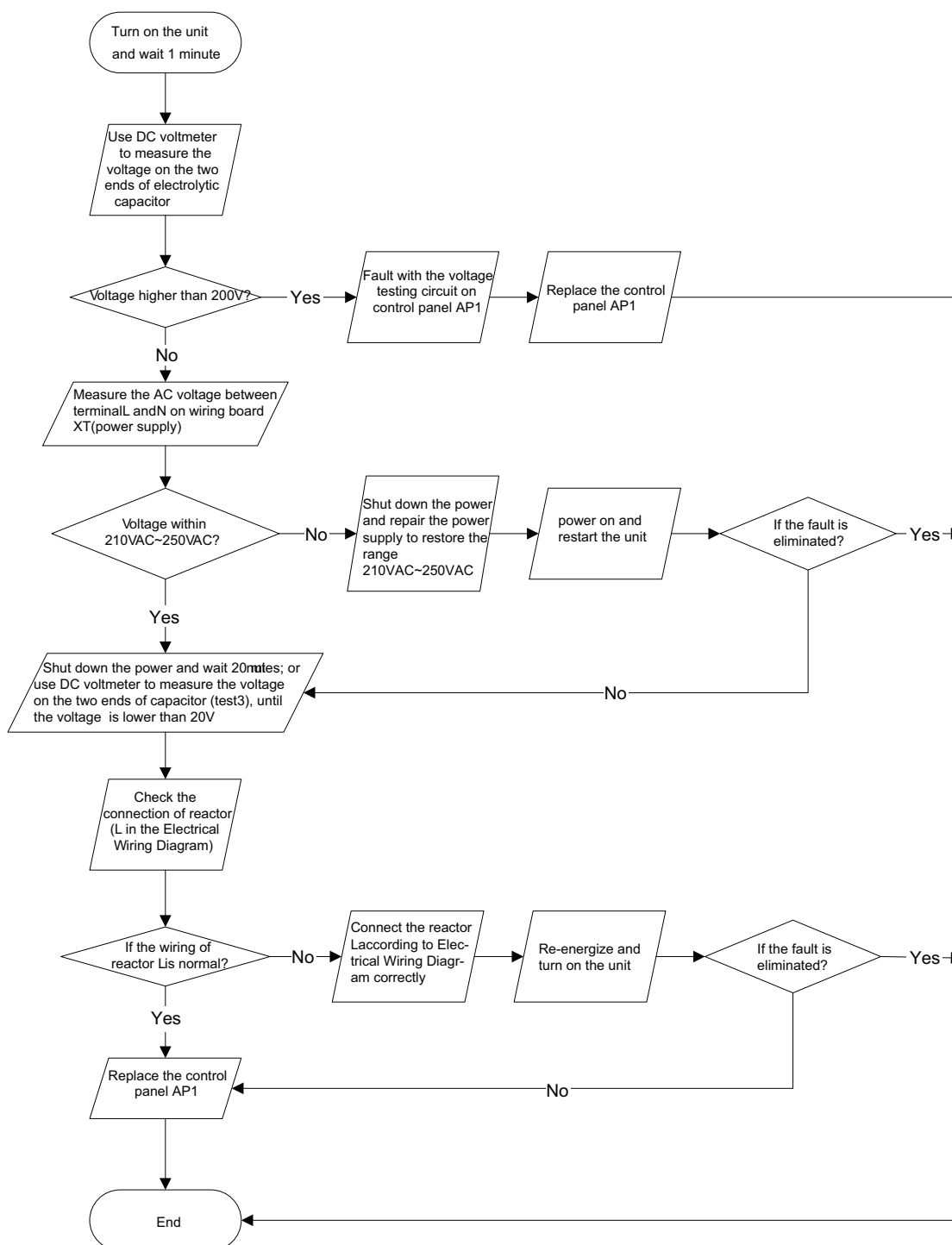

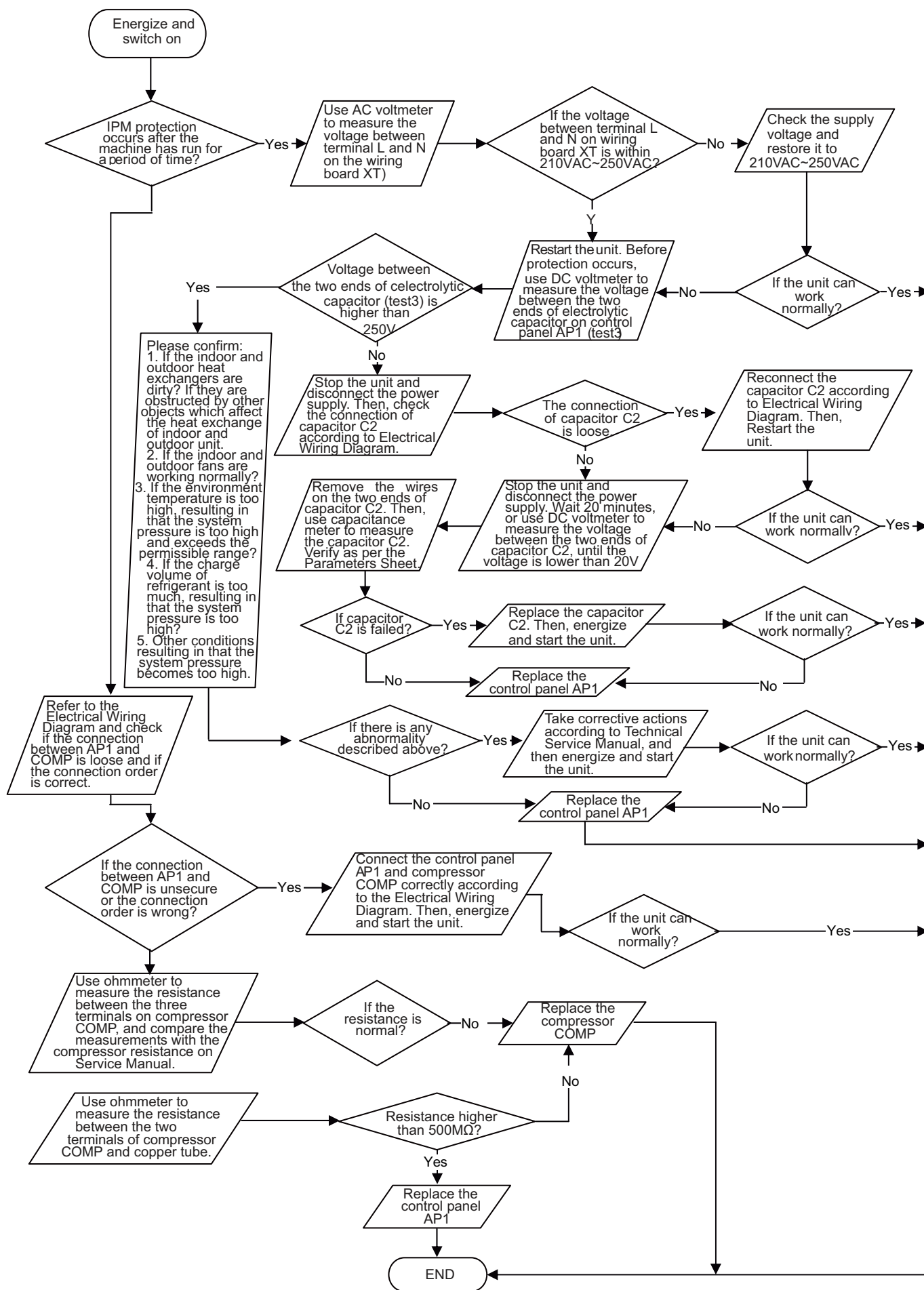

5. Diagnosis for failure start up malfunction (AP1 below is control board of outdoor unit)

Main detection point:

- If the compressor wiring is correct?
- If the stop time of compressor is enough?
- If the compressor is damaged?
- If the refrigerant charging is too much?

Malfunction diagnosis process:

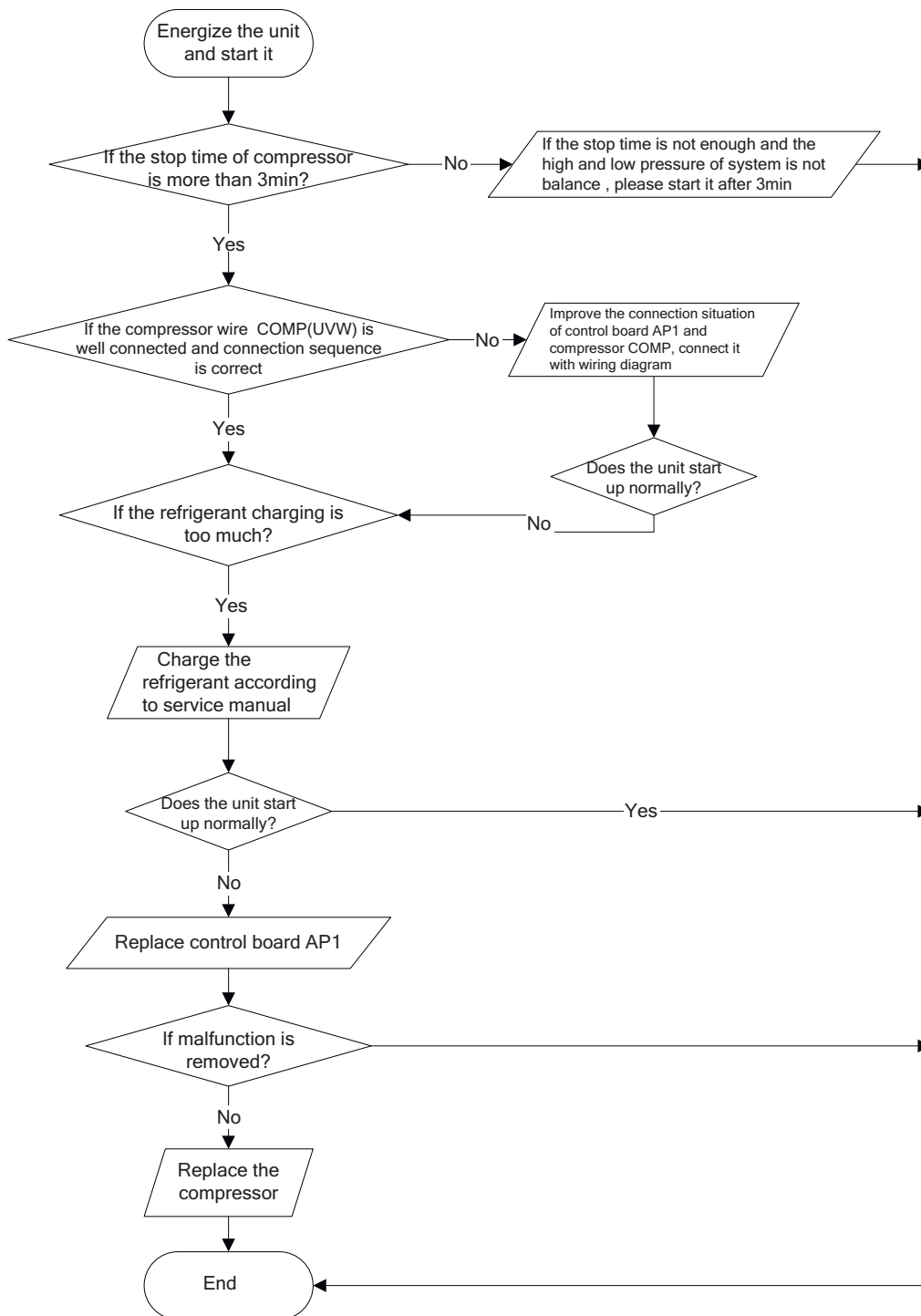

6. Diagnosis for compressor synchronism (AP1 below is control board of outdoor unit)

Main detection point:

- If the system pressure is over-high?
- If the work voltage is over-low?

Malfunction diagnosis process:



7. Diagnosis for overload and discharge malfunction (AP1 below is control board of outdoor unit)

Main detection point:

- If the electron expansion valve is connected well? Is the expansion valve damaged?
- If the refrigerant is leakage?
- If the overload protector is damaged?

Malfunction diagnosis process:

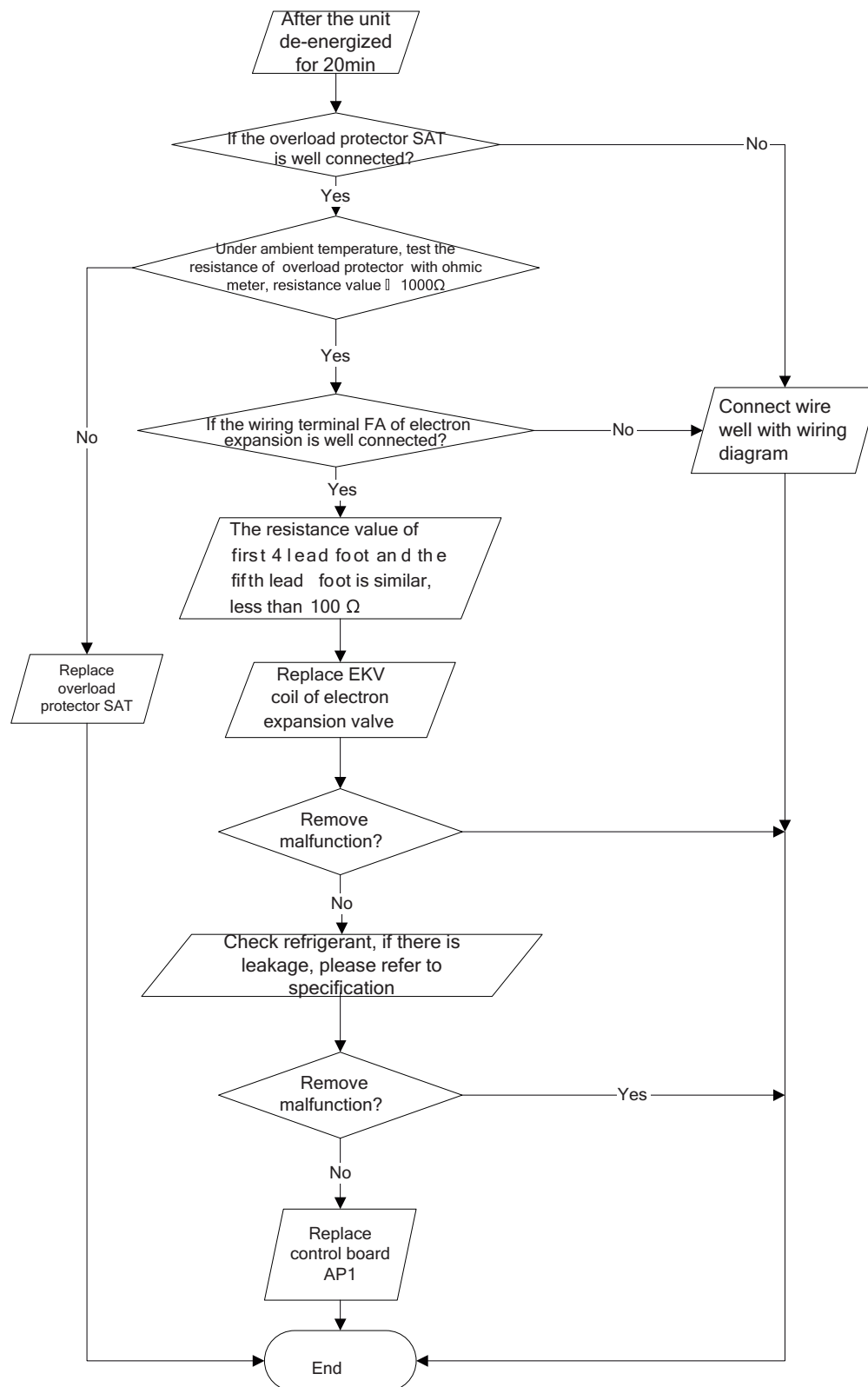

9. Communication malfunction (AP1 below is control board of outdoor unit)

Main detection point:

- Check if the connection wire and the built-in wiring of indoor and outdoor unit is connected well and no damaged;
- If the communication circuit of indoor mainboard is damaged? If the communication circuit of outdoor mainboard (AP1) is damaged

Malfunction diagnosis process:

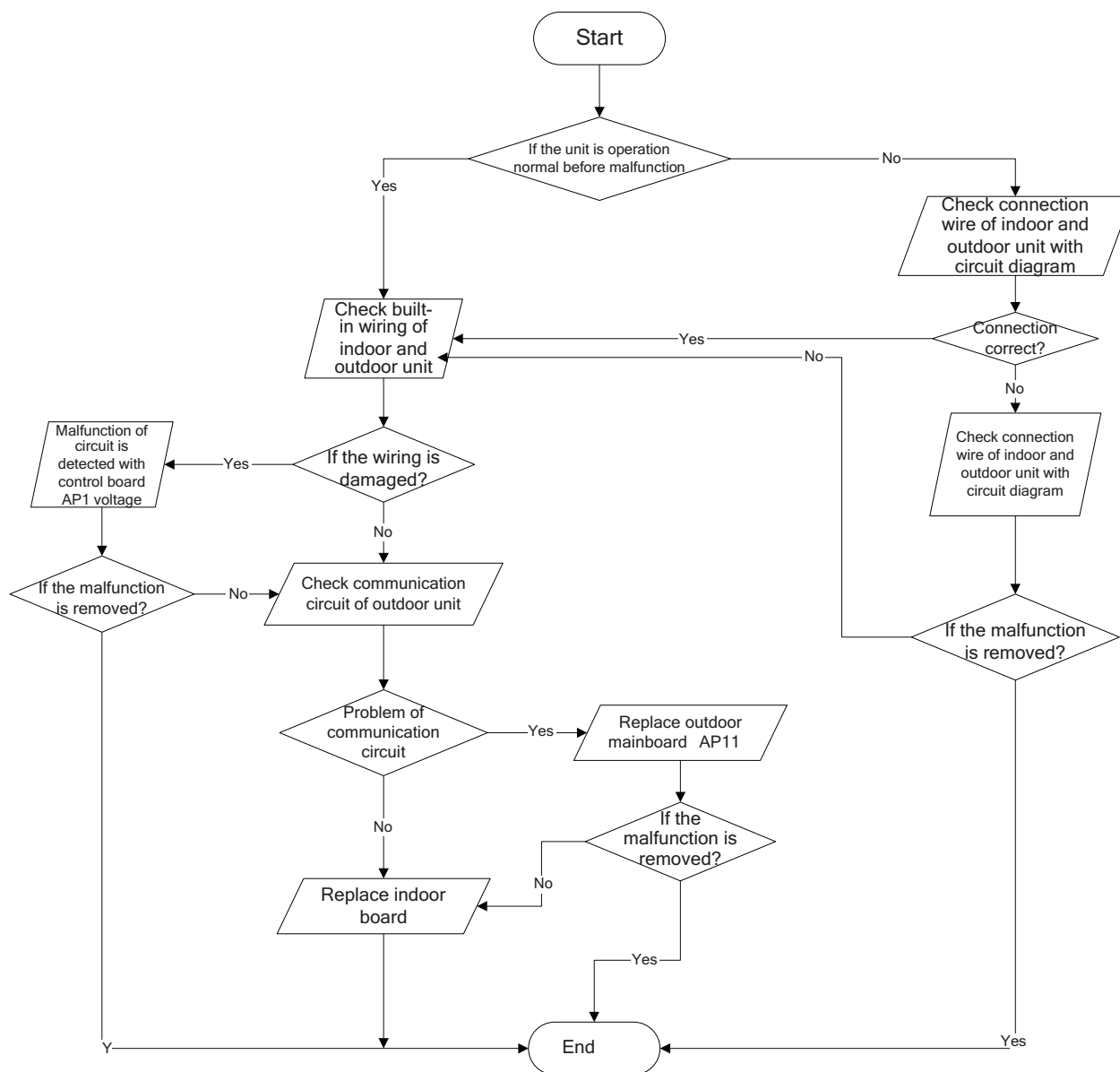

10. Diagnosis process for outdoor communication circuit

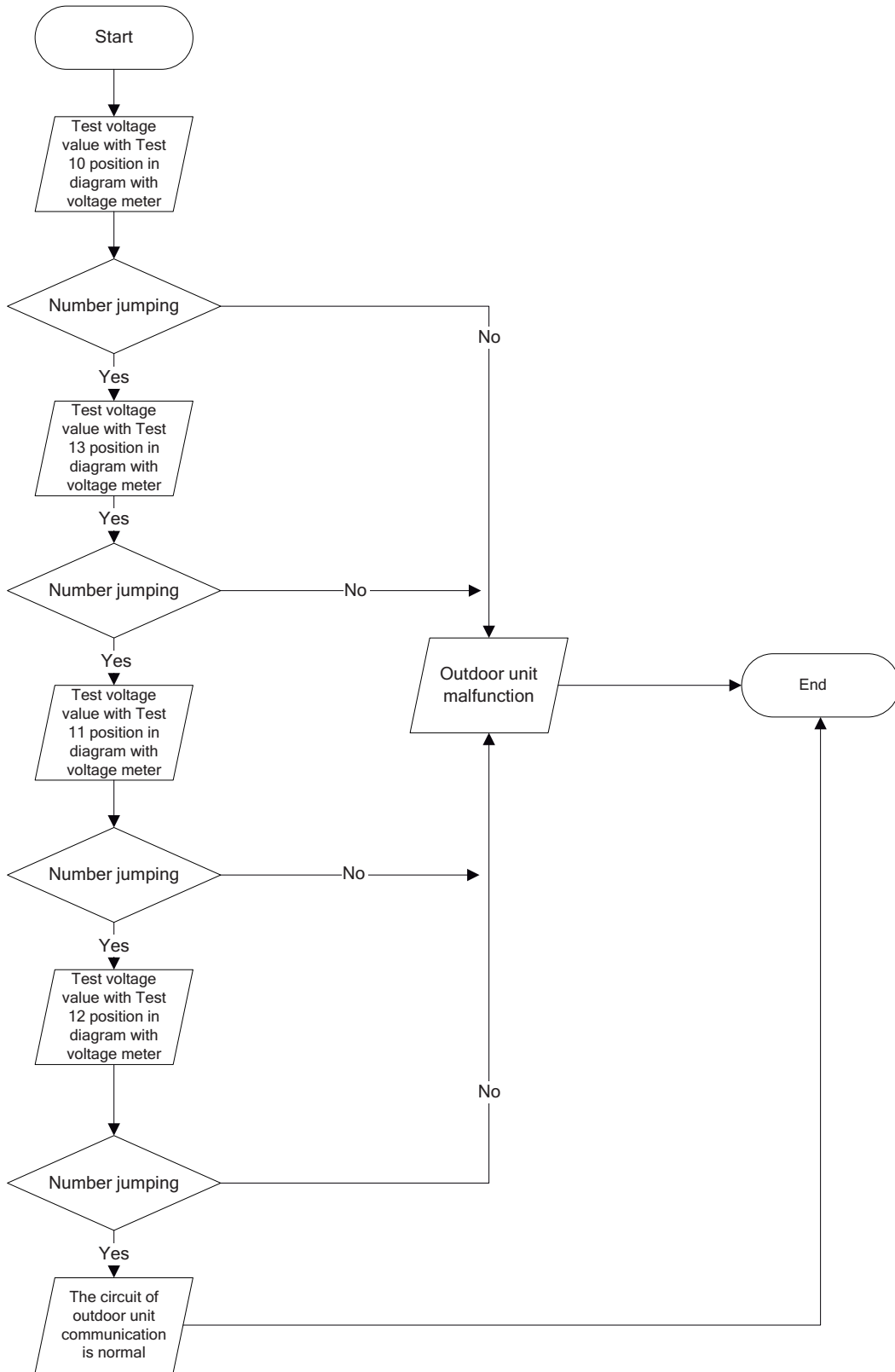

11. Malfunction of Overcurrent Protection E5

Main detection points:

- Is the supply voltage unstable with big fluctuation?
- Is the supply voltage too low with overload?
- Hardware trouble?

Malfunction diagnosis process:

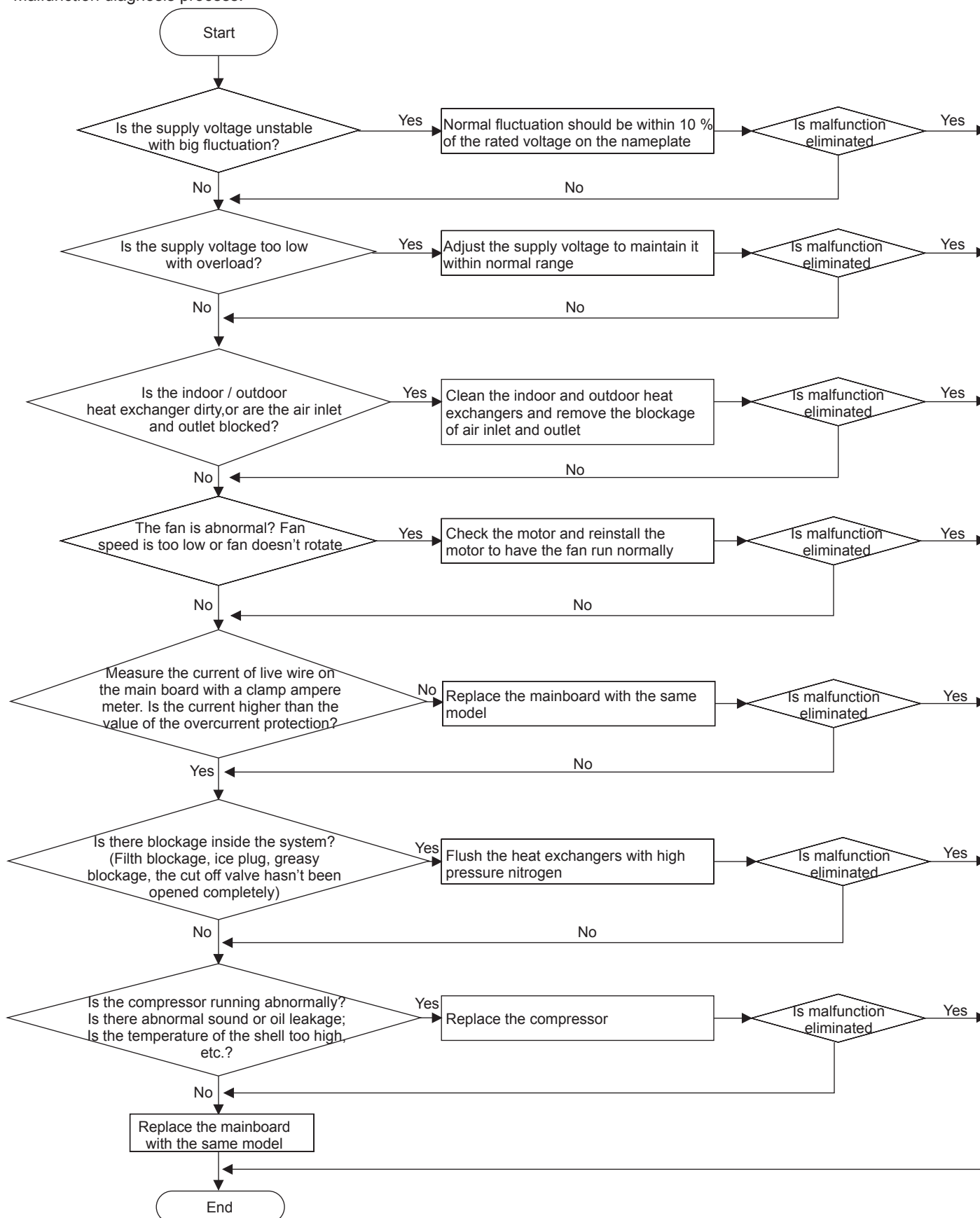

9.3 Troubleshooting for Normal Malfunction

1. Air Conditioner Can't be Started Up

Possible Causes	Discriminating Method (Air conditioner Status)	Troubleshooting
No power supply, or poor connection for power plug	After energization, operation indicator isn't bright and the buzzer can't give out sound	Confirm whether it's due to power failure. If yes, wait for power recovery. If not, check power supply circuit and make sure the power plug is connected well.
Wrong wire connection between indoor unit and outdoor unit, or poor connection for wiring terminals	Under normal power supply circumstances, operation indicator isn't bright after energization	Check the circuit according to circuit diagram and connect wires correctly. Make sure all wiring terminals are connected firmly
Electric leakage for air conditioner	After energization, room circuit breaker trips off at once	Make sure the air conditioner is grounded reliably Make sure wires of air conditioner is connected correctly Check the wiring inside air conditioner. Check whether the insulation layer of power cord is damaged; if yes, place the power cord.
Model selection for air switch is improper	After energization, air switch trips off	Select proper air switch
Malfunction of remote controller	After energization, operation indicator is bright, while no display on remote controller or buttons have no action.	Replace batteries for remote controller Repair or replace remote controller

2. Poor Cooling (Heating) for Air Conditioner

Possible Causes	Discriminating Method (Air conditioner Status)	Troubleshooting
Set temperature is improper	Observe the set temperature on remote controller	Adjust the set temperature
Rotation speed of the IDU fan motor is set too low	Small wind blow	Set the fan speed at high or medium
Filter of indoor unit is blocked	Check the filter to see it's blocked	Clean the filter
Installation position for indoor unit and outdoor unit is improper	Check whether the installation position is proper according to installation requirement for air conditioner	Adjust the installation position, and install the rainproof and sunproof for outdoor unit
Refrigerant is leaking	Discharged air temperature during cooling is higher than normal discharged wind temperature; Discharged air temperature during heating is lower than normal discharged wind temperature; Unit's pressure is much lower than regulated range	Find out the leakage causes and deal with it. Add refrigerant.
Malfunction of 4-way valve	Blow cold wind during heating	Replace the 4-way valve
Malfunction of capillary	Discharged air temperature during cooling is higher than normal discharged wind temperature; Discharged air temperature during heating is lower than normal discharged wind temperature; Unit's pressure is much lower than regulated range. If refrigerant isn't leaking, part of capillary is blocked	Replace the capillary
Flow volume of valve is insufficient	The pressure of valves is much lower than that stated in the specification	Open the valve completely
Malfunction of horizontal louver	Horizontal louver can't swing	Refer to point 3 of maintenance method for details
Malfunction of the IDU fan motor	The IDU fan motor can't operate	Refer to troubleshooting for H6 for maintenance method in details
Malfunction of the ODU fan motor	The ODU fan motor can't operate	Refer to point 4 of maintenance method for details
Malfunction of compressor	Compressor can't operate	Refer to point 5 of maintenance method for details

3. Horizontal Louver Can't Swing

Possible Causes	Discriminating Method (Air conditioner Status)	Troubleshooting
Wrong wire connection, or poor connection	Check the wiring status according to circuit diagram	Connect wires according to wiring diagram to make sure all wiring terminals are connected firmly
Stepping motor is damaged	Stepping motor can't operate	Repair or replace stepping motor
Main board is damaged	Others are all normal, while horizontal louver can't operate	Replace the main board with the same model

4. ODU Fan Motor Can't Operate

Possible causes	Discriminating method (air conditioner status)	Troubleshooting
Wrong wire connection, or poor connection	Check the wiring status according to circuit diagram	Connect wires according to wiring diagram to make sure all wiring terminals are connected firmly
Capacity of the ODU fan motor is damaged	Measure the capacity of fan capacitor with an universal meter and find that the capacity is out of the deviation range indicated on the nameplate of fan capacitor.	Replace the capacity of fan
Power voltage is a little low or high	Use universal meter to measure the power supply voltage. The voltage is a little high or low	Suggest to equip with voltage regulator
Motor of outdoor unit is damaged	When unit is on, cooling/heating performance is bad and ODU compressor generates a lot of noise and heat.	Change compressor oil and refrigerant. If no better, replace the compressor with a new one

5. Compressor Can't Operate

Possible causes	Discriminating method (air conditioner status)	Troubleshooting
Wrong wire connection, or poor connection	Check the wiring status according to circuit diagram	Connect wires according to wiring diagram to make sure all wiring terminals are connected firmly
Capacity of compressor is damaged	Measure the capacity of fan capacitor with an universal meter and find that the capacity is out of the deviation range indicated on the nameplate of fan capacitor.	Replace the compressor capacitor
Power voltage is a little low or high	Use universal meter to measure the power supply voltage. The voltage is a little high or low	Suggest to equip with voltage regulator
Coil of compressor is burnt out	Use universal meter to measure the resistance between compressor terminals and it's 0	Repair or replace compressor
Cylinder of compressor is blocked	Compressor can't operate	Repair or replace compressor

6. Air Conditioner is Leaking

Possible causes	Discriminating method (air conditioner status)	Troubleshooting
Drain pipe is blocked	Water leaking from indoor unit	Eliminate the foreign objects inside the drain pipe
Drain pipe is broken	Water leaking from drain pipe	Replace drain pipe
Wrapping is not tight	Water leaking from the pipe connection place of indoor unit	Wrap it again and bundle it tightly

7. Abnormal Sound and Vibration

Possible causes	Discriminating method (air conditioner status)	Troubleshooting
When turn on or turn off the unit, the panel and other parts will expand and there's abnormal sound	There's the sound of "PAPA"	Normal phenomenon. Abnormal sound will disappear after a few minutes.
When turn on or turn off the unit, there's abnormal sound due to flow of refrigerant inside air conditioner	Water-running sound can be heard	Normal phenomenon. Abnormal sound will disappear after a few minutes.
Foreign objects inside the indoor unit or there're parts touching together inside the indoor unit	There's abnormal sound fro indoor unit	Remove foreign objects. Adjust all parts' position of indoor unit, tighten screws and stick damping plaster between connected parts
Foreign objects inside the outdoor unit or there're parts touching together inside the outdoor unit	There's abnormal sound fro outdoor unit	Remove foreign objects. Adjust all parts' position of outdoor unit, tighten screws and stick damping plaster between connected parts
Short circuit inside the magnetic coil	During heating, the way valve has abnormal electromagnetic sound	Replace magnetic coil
Abnormal shake of compressor	Outdoor unit gives out abnormal sound	Adjust the support foot mat of compressor, tighten the bolts
Abnormal sound inside the compressor	Abnormal sound inside the compressor	If add too much refrigerant during maintenance, please reduce refrigerant properly. Replace compressor for other circumstances.

NO.	Description	Part Code		Qty
		GWH09UB-K3DNA4F/I (Cold Plasma)	GWH09UB-K3DNA4F/I (Cold Plasma)	
		Product Code	Product Code	
1	Front Panel Sub-Assy	2002264105	2002264104	1
2	Stand Bar	10582150P	10582150P01	1
3	Screw Cover	24252028P	24252028P01	1
4	Cover Plate	20122190P	20122190P01	1
5	Left Decorative Board	20192574D03	20192574D03	1
6	Left Side Plate	20052027P	20052027P01	1
7	Left Driving Box Sub-assy	2011218903	2011218904	1
8	Front Case Assy	20022470	20022412	1
9	Decorative Strip (Up)	20192572D03	20192572D03	1
10	Swing Lever	10582134	10582134	1
11	Air Louver (left)	10512309	10512309	1
12	Filter Sub-Assy	11122145	11122145	2
13	Ring of Bearing	26152022	26152022	1
14	O-Gasket sub-assy of Bearing	76512056	76512056	1
15	Cross Flow Fan	10352050	10352050	1
16	Drainage Hose	05230014	05230014	1
17	Evaporator Support	24212157	24212157	1
18	Evaporator Assy	0100241702	0100241702	1
19	Breakwater	26112345	26112345	1
20	Cold Plasma Generator	1114001601	1114001602	1
21	Motor Press Plate	26112346	26112346	1
22	Fan Motor	15012140	15012140	1
23	Connecting pipe clamp	2611216401	2611216401	1
24	Wall Mounting Frame	01252484	01252484	1
25	Jumper	4202300123	4202300123	1
26	Main Board	30138000654	30138000654	1
27	Mouseproof Board	26112344	26112344	1
28	Shield Cover of Electric Box Sub-assy	01592126	01592126	1
29	Electric Box Assy	10000201566	10000201566	1
30	Rear Case assy	22202289	22202289	1
31	Helicoid Tongue sub-assy	26112350	26112350	1
32	Helicoid Tongue	26112343	26112343	1
33	Louver Motor Sub-assy (Left and Right)	15002019	15002019	1
34	Crank 1	73012026	73012026	1
35	Air Louver(right)	10512718	10512718	1
36	Right Side Plate	20052026P	20052026P01	1
37	Right Decorative Board	20192573D03	20192573D03	1
38	Right Driving Box Sub-assy	2011219003	2011219004	1
39	Electric Box Cover Sub-Assy	20122192	2012219201	1
40	Display Board	30568248	30568248	1
41	Detecting Plate	30070049	30070049	1
42	Front Panel	20022393	20022393	1
43	Front Panel	2002264205	2002264204	1
44	Guide Louver	1051291101	10512911	1
45	Remote Controller	30510559	30510559	1
46	Filter (antimicrobial)	/	/	/
47	Temperature Sensor	390000594	390000594	1
48	Temperature Sensor	390000455	390000455	1

Above data is subject to change without notice.

NO.	Description	Part Code		Qty
		GWH12UB-K3DNA4F/I (Cold Plasma)	GWH12UB-K3DNA4F/I (Cold Plasma)	
		Product Code CB264N00701	Product Code CB264N00700	
1	Front Panel Sub-Assy	2002264104	2002264105	1
2	Stand Bar	10582150P01	10582150P	1
3	Screw Cover	24252028P01	24252028P	1
4	Cover Plate	20122190P01	20122190P	1
5	Left Decorative Board	20192574D03	20192574D03	1
6	Left Side Plate	20052027P01	20052027P	1
7	Left Driving Box Sub-assy	2011218904	2011218903	1
8	Front Case Assy	20022412	20022470	1
9	Decorative Strip (Up)	20192572D03	20192572D03	1
10	Swing Lever	10582134	10582134	1
11	Air Louver (left)	10512309	10512309	1
12	Filter Sub-Assy	11122145	11122145	2
13	Ring of Bearing	26152022	26152022	1
14	O-Gasket sub-assy of Bearing	76512056	76512056	1
15	Cross Flow Fan	10352050	10352050	1
16	Drainage Hose	05230014	05230014	1
17	Evaporator Support	24212157	24212157	1
18	Evaporator Assy	0100241702	0100241702	1
19	Breakwater	26112345	26112345	1
20	Cold Plasma Generator	1114001602	1114001601	1
21	Motor Press Plate	26112346	26112346	1
22	Fan Motor	15012140	15012140	1
23	Connecting pipe clamp	2611216401	2611216401	1
24	Wall Mounting Frame	01252484	01252484	1
25	Jumper	4202300124	4202300124	1
26	Main Board	30138000654	30138000654	1
27	Mouseproof Board	26112344	26112344	1
28	Shield Cover of Electric Box Sub-assy	01592126	01592126	1
29	Electric Box Assy	10000201567	10000201567	1
30	Rear Case assy	22202289	22202289	1
31	Helicoid Tongue sub-assy	26112350	26112350	1
32	Helicoid Tongue	26112343	26112343	1
33	Louver Motor Sub-assy (Left and Right)	15002019	15002019	1
34	Crank 1	73012026	73012026	1
35	Air Louver(right)	10512718	10512718	1
36	Right Side Plate	20052026P01	20052026P	1
37	Right Decorative Board	20192573D03	20192573D03	1
38	Right Driving Box Sub-assy	2011219004	2011219003	1
39	Electric Box Cover Sub-Assy	2012219201	20122192	1
40	Display Board	30568248	30568248	1
41	Detecting Plate	30070049	30070049	1
42	Front Panel	20022393	20022393	1
43	Front Panel	20022393	2002264205	1
44	Guide Louver	10512911	1051291101	1
45	Remote Controller	30510559	30510559	1
46	Filter (antimicrobial)	/	/	/
47	Temperature Sensor	390000594	390000594	1
48	Temperature Sensor	390000455	390000455	1

Above data is subject to change without notice.

GWH18UC-K3DNA4F/I(Cold Plasma)

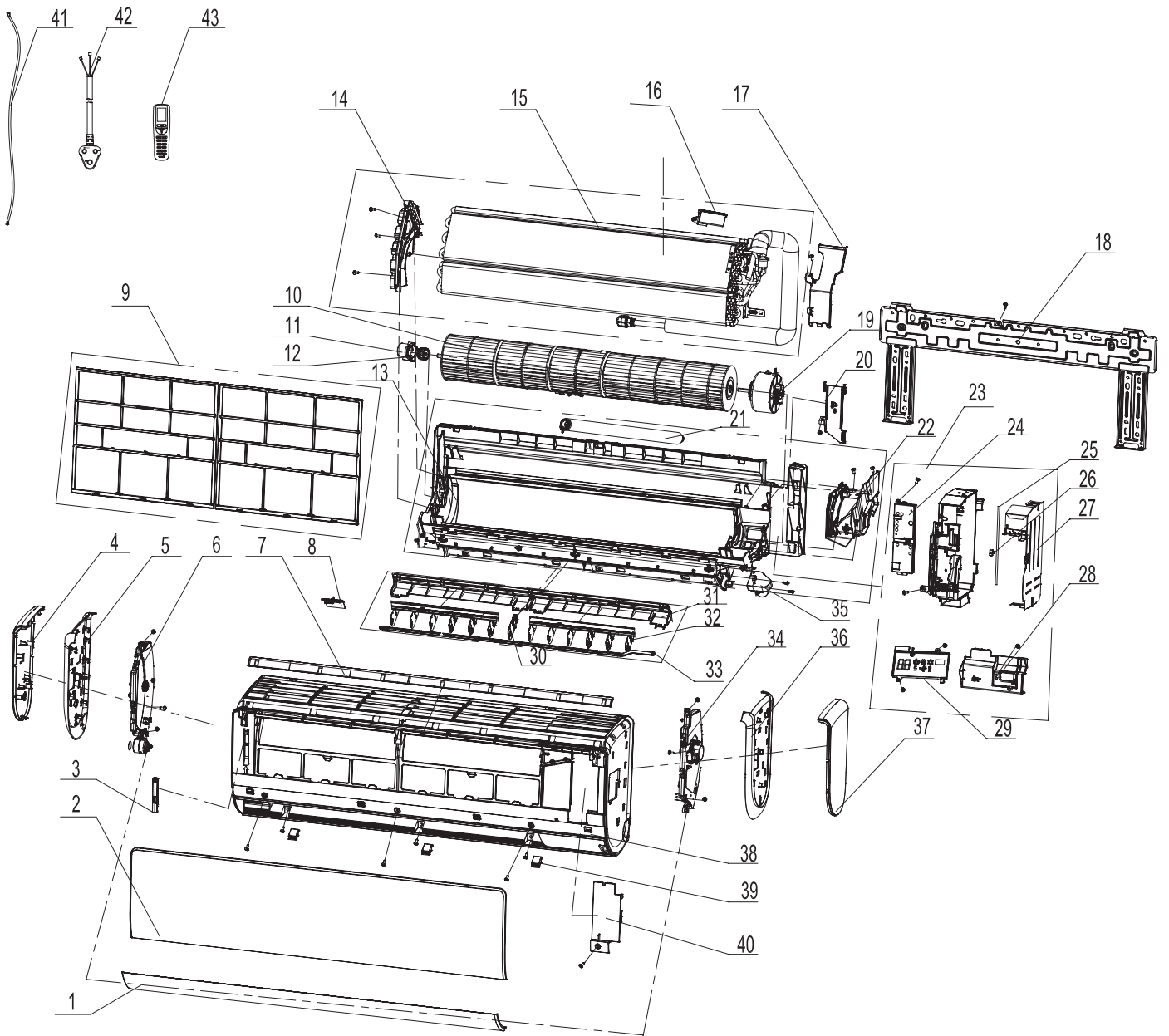

NO.	Description	Part Code		Qty
		GWH18UC-K3DNA4F/I (Cold Plasma)	GWH18UC-K3DNA4F/I (Cold Plasma)	
		Product Code	Product Code	
		CB264N00500	CB264N00501	
1	Guide Louver	10512916	1051291601	1
2	Front Panel	2002240902	2002240901	1
3	Stand Bar	10582150P	10582150P01	1
4	Left Side Plate	26112361B	26112361B	1
5	Left Decorative Board	20192600	20192600	1
6	Left Driving Box Sub-assy	2011220101	20112201	1
7	Decorative Strip (Up)	20192602	20192602	1
8	Cover plate(Air Outlet)	20122193P	20122193P01	1
9	Filter Sub-Assy	11122155	11122155	2
10	Cross Flow Fan	10352054	10352054	1
11	Ring of Bearing	26152022	26152022	1
12	O-Gasket sub-assy of Bearing	7651205102	7651205102	1
13	Rear Case	2220229602	2220229602	1
14	Evaporator Support	24212170	24212170	1
15	Evaporator Assy	01002658	01100100177	1
16	Cold Plasma Generator	1114001602	1114001602	1
17	Breakwater	26112359	26112359	1
18	Wall Mounting Frame	01252040	01252040	1
19	Fan Motor	15012466	15012466	1
20	Connecting pipe clamp	2611216401	2611216401	1
21	Drainage Hose	05230014	05230014	1
22	Motor Press Plate	26112360	26112360	1
23	Electric Box Assy	10000201564	10000201564	1
24	Detecting Plate	30070049	30070049	1
25	Main Board	30138000653	30138000653	1
26	Jumper	4202021918	4202021918	1
27	Shield Cover of Electric Box Sub-assy	01592131	01592131	1
28	Mouseproof Board	26112358	26112358	1
29	Display Board	30568247	30568247	1
30	Air Louver (Middle)	1051291701	1051291701	1
31	Helicoid Tongue	2611235702	2611235702	1
32	Air Louver	1051229202	1051229202	2
33	Swing Lever	1058214702	1058214702	1
34	Right Driving Box Sub-assy	2011220001	20112200	1
35	Louver Motor Sub-assy (Left and Right)	15002021	15002021	1
36	Right Decorative Board	20192601	20192601	1
37	Right Side Plate	26112362B	26112362B	1
38	Front Case	20022410B	20022410B	1
39	Screw Cover	24252029P	24252029P01	3
40	Electric Box Cover Sub-Assy	2012219701	20122197	1
41	Connecting Cable	4002052317	4002052317	0
42	Power Cord	/	/	/
43	Remote Controller	30510559	30510559	1

Above data is subject to change without notice.

10.2 Outdoor Unit

GWH09UB-K3DNA4F/O GWH12UB-K3DNA4F/O

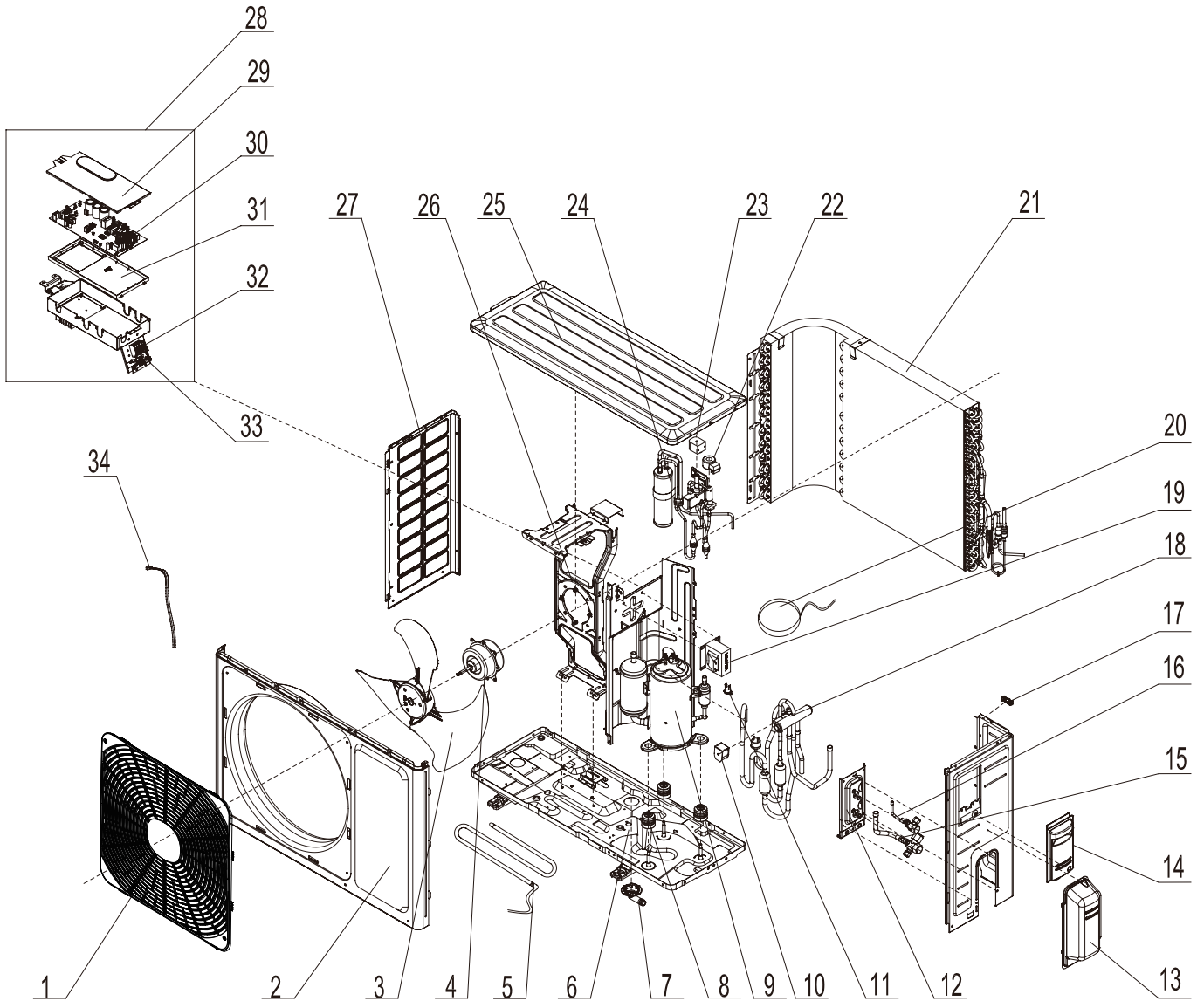

NO.	Description	Part Code		Qty
		GWH09UB-K3DNA4F/O	GWH12UB-K3DNA4F/O	
		Product Code	Product Code	
		CB264W00600	CB264W00700	
1	Front Grill	22413038	22413038	1
2	Cabinet	01433034P	01433034P	1
3	Axial Flow Fan	10333022	10333022	1
4	Fan Motor	1501308507	1501308507	1
5	Electrical Heater (Chassis)	76510004	76510004	1
6	Chassis Sub-assy	0280311901P	0280311901P	1
7	Drainage Joint	26113009	26113009	1
8	Compressor Gasket	76713074	76713074	3
9	Compressor and Fittings	00103977	00103977	1
10	Magnet Coil	4300008301	4300008301	1
11	Compressor Overload Protector(External)	00183051	00183051	1
12	Valve Support Sub-Assy	01703242P	01703242P	1
13	Valve Cover	22243005	22243005	1
14	Big Handle	2623343106	2623343106	1
15	Cut off Valve Sub-Assy	07100006	07100006	1
16	Cut off Valve Sub-Assy	0713376301	0713376301	1
17	Wiring Clamp	26115004	26115004	1
18	4-Way Valve Assy	03073358	03073358	1
19	Reactor	43130185	43130185	1
20	Electrical Heater(Compressor)	/	/	/
21	Condenser Assy	01100200314	01100200314	1
22	Electric Expand Valve Fitting	4300876704	4300876704	1
23	Magnet Coil	4300008301	4300008301	1
24	Flash Vaporizer Assy	07223057	07223057	1
25	Coping	01253034P	01253034P	1
26	Motor Support Sub-Assy	01703180	01703180	1
27	Left Side Plate	01303169P	01303169P	1
28	Electric Box Assy	10000100252	10000100256	1
29	Electric Box Cover Sub-Assy	0260309601	0260309601	1
30	Main Board	30138000643	30138000644	1
31	Electric Box 1	20113005	20113005	1
32	Terminal Board	42010313	42010313	1
33	Wire Clamp	71010003	71010003	1
34	Temperature Sensor	39000079	39000079	1

Above data is subject to change without notice.

GWH18UC-K3DNA4F/O

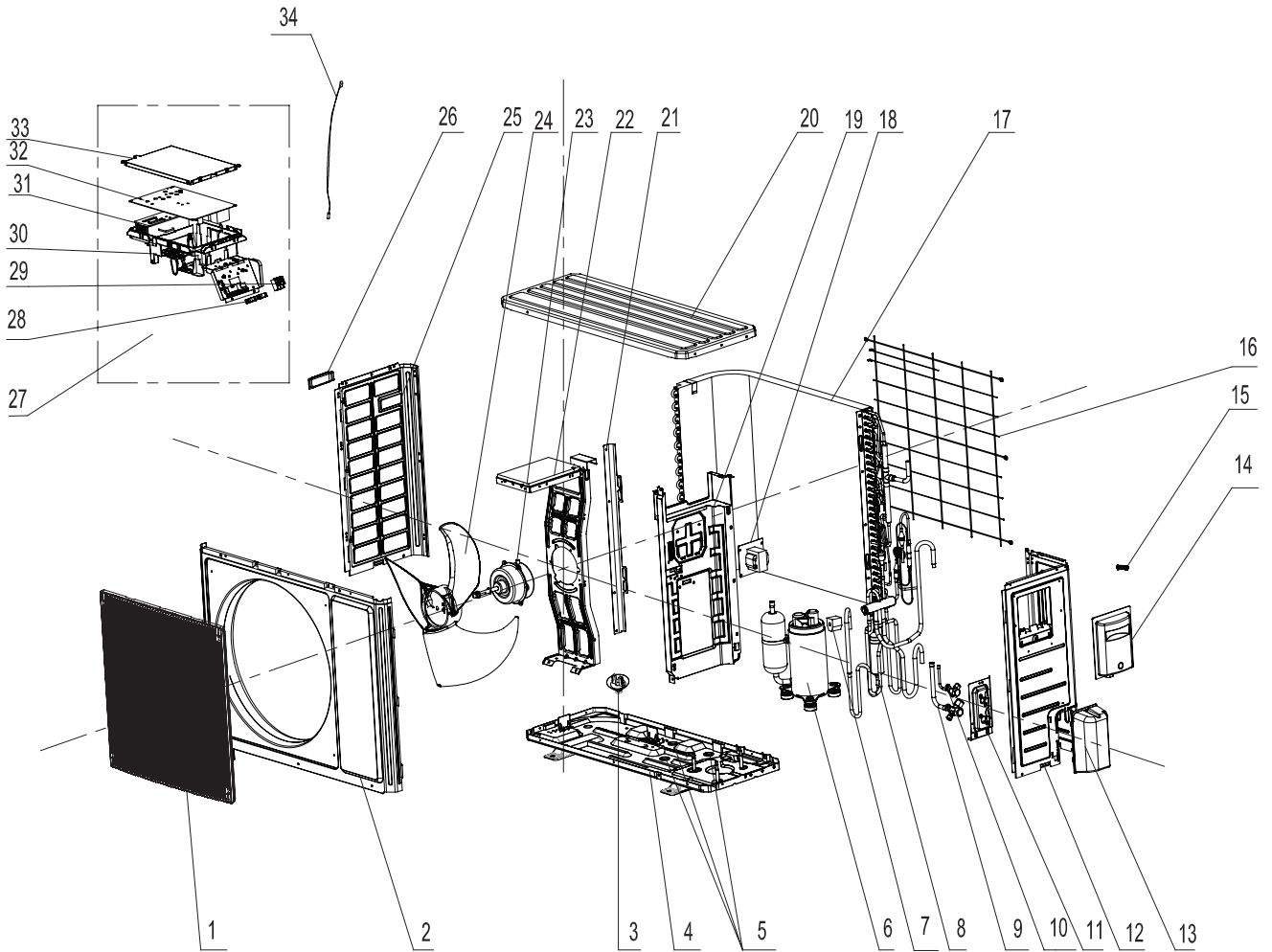

No.	Description	Part Code	Qty
		GWH18UC-K3DNA4F/O	
	Product Code	CB264W00500	
1	Front Grill	22415010	1
2	Front Panel	01535013P	1
3	Drainage Connector	06123401	1
4	Chassis Sub-assy	01700000016P	1
5	Drainage hole Cap	06813401	1
		76713033	1
		76713068	1
6	Compressor and fittings	00105260	1
7	Magnet Coil	4300040078	1
8	4-Way Valve Assy	0302552701	1
9	Cut off Valve Assy 1/2	0713522001	1
10	Cut off Valve Sub-Assy	0713522301	1
11	Valve support assy	01705066P	1
12	Right Side Plate	0130509402P	1
13	Valve cover	22245002	1
14	Handle	26233053	1
15	Wiring Clamp	26115004	1
16	Rear Grill	01473043	1
17	Condenser Assy	0110573501	1
18	Reactor	43130186	1
19	Clapboard Assy	01235088	1
20	Coping	01255005P	1
21	Supporting Board(Condenser)	01795010	1
22	Motor Support Sub-Assy	01705036	1
23	Fan Motor	1501506402	1
24	Axial Flow Fan	10335008	1
25	Left Side Plate	01305093P	1
26	left handle	2623525404	1
27	Electric Box Assy	10000100254	1
28	Wire Clamp	71010003	1
29	Terminal Board	420101943	1
30	Electric Box	20115003	1
31	Radiator	49015215	1
32	Main Board	30138000648	1
33	Insulated Board (Cover of Electric Box)	70410523	1
34	Temperature Sensor	39000072	1

Above data is subject to change without notice.

11. Removal Procedure

! Caution: discharge the refrigerant completely before removal.

11.1 Removal Procedure of Indoor Unit

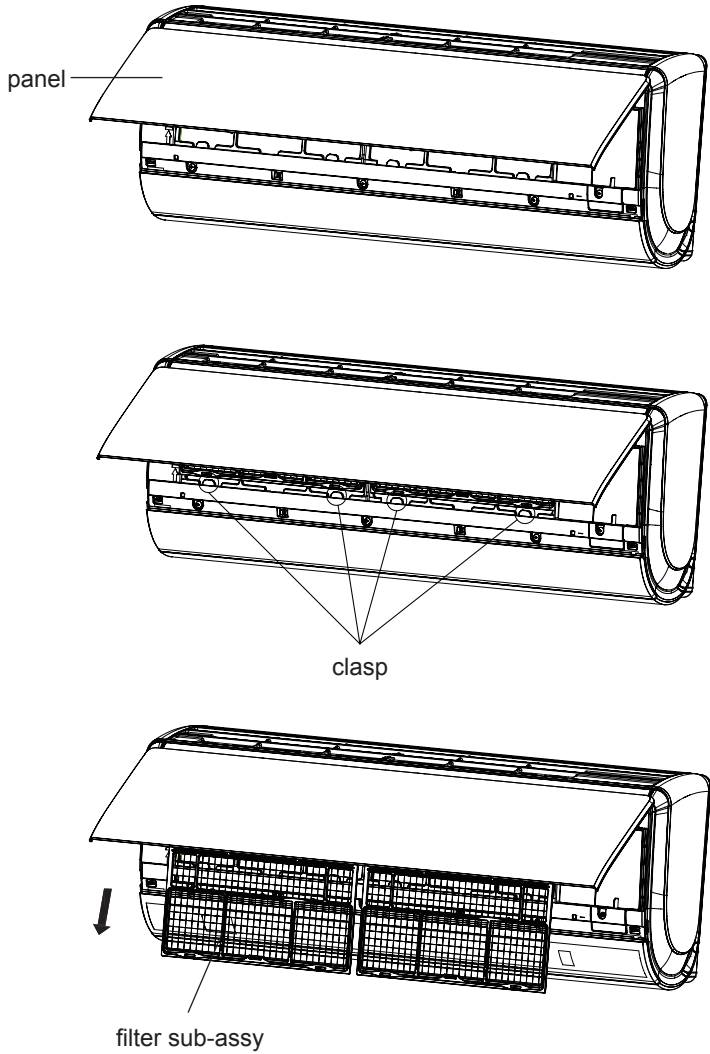
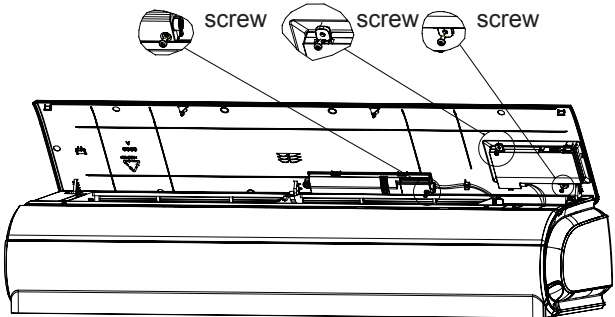
Steps	Procedure
1. Remove filter sub-assy	 <p>The diagram illustrates the removal of the filter sub-assembly in three sequential steps:</p> <ul style="list-style-type: none"> a Open the panel. The top cover of the indoor unit is shown being lifted. b Remove clasps on filter. The top cover is fully open, and the clasp mechanism is shown being released. c Remove filter sub-assy with hand. The filter sub-assembly is shown being pulled out from the unit.
2. Remove panel	 <p>The diagram shows the panel being removed by unscrewing three screws from the sealing cover. The screws are labeled 'screw'.</p>

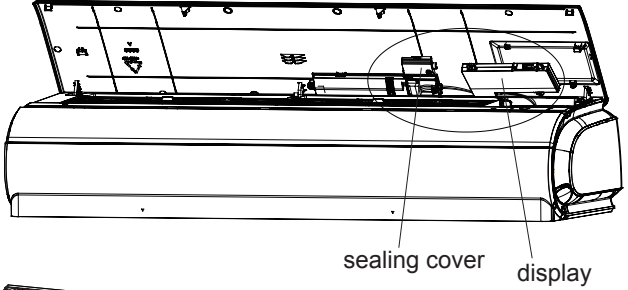
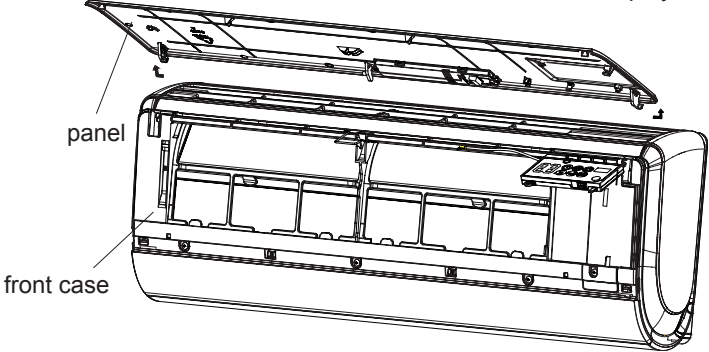
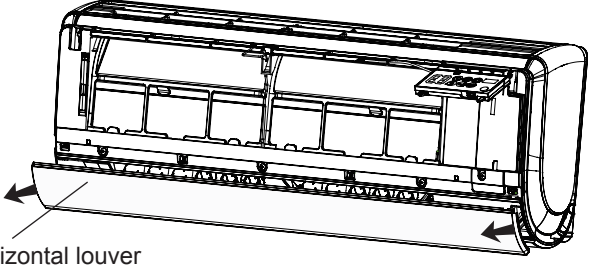
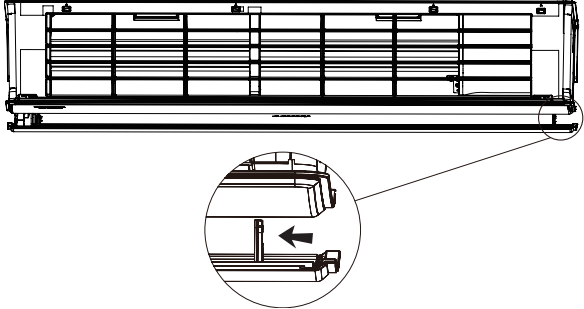
Steps		Procedure
b	Remove sealing cover and display.	 <p>sealing cover display</p>
c	Remove hinges at both sides of panel to separate panel and front case and then remove the panel.	 <p>panel front case</p>
3. Remove horizontal louver and front case		
a	Cut off power, hold both ends of horizontal louver with hand, and then draw it out horizontally.	 <p>horizontal louver</p>
b	Remove right end at first. Hold the right end of horizontal louver, push the connection rod with thumb to separate the connection rod and horizontal louver.	

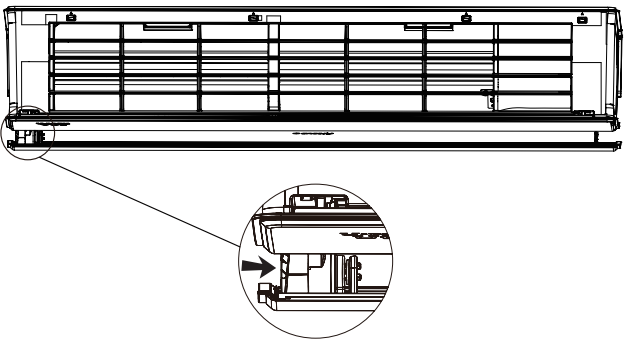
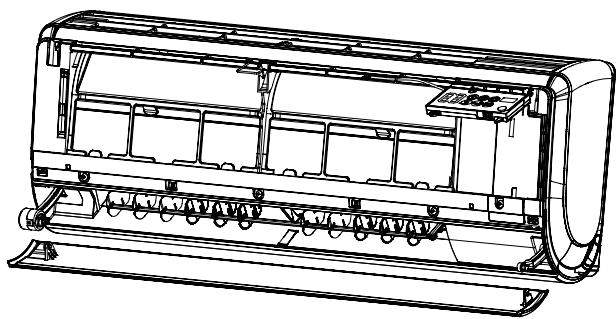
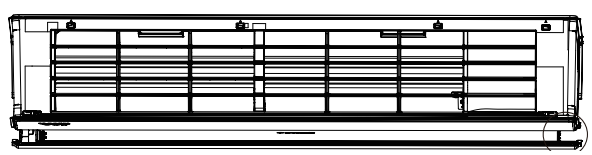
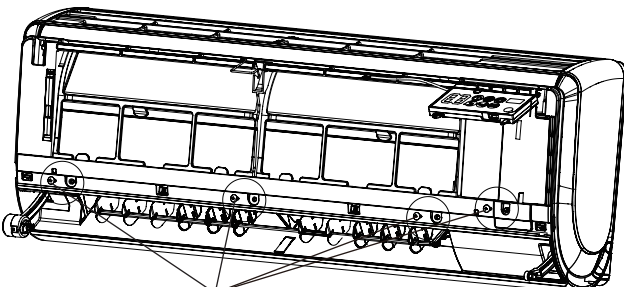
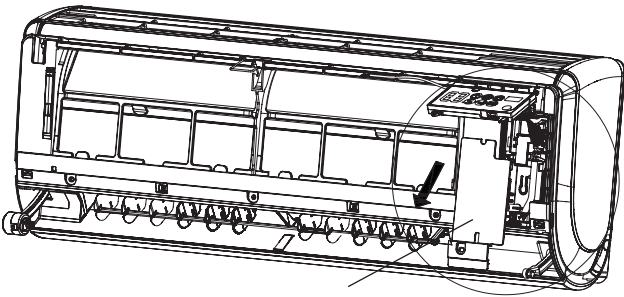
Steps		Procedure
c	Remove the left end. Hold the end of connection rod with left hand, hold the horizontal louver with right hand to separate connection rod and horizontal louver.	
d	Remove the horizontal louver along the axle center direction.	
e	Note: (during operation, install the left end and then install the right end. After installation, re-energize the unit until the horizontal louver is reset. After that, you can operate the unit).	
f	Remove 4 screws on front case and electric box cover with screwdriver.	 <p style="text-align: center;">screws</p>
g	Remove electric box cover.	 <p style="text-align: center;">electric box cover</p>

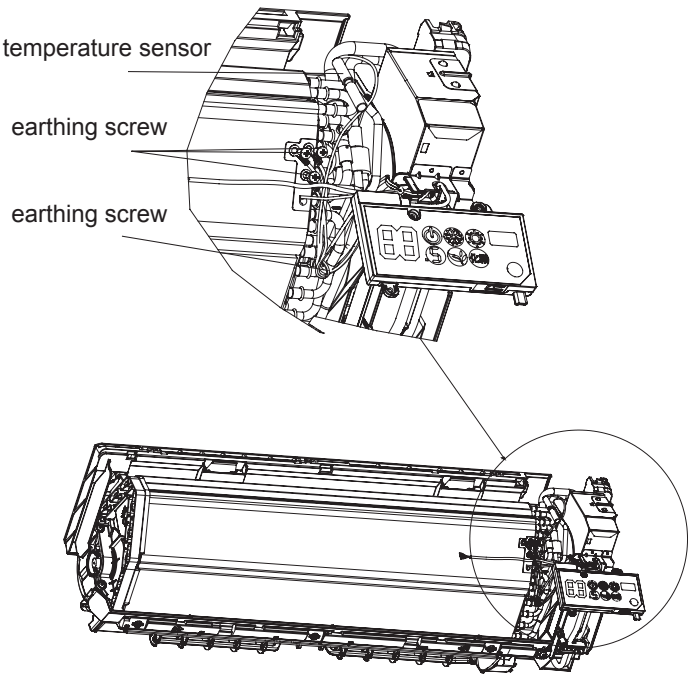
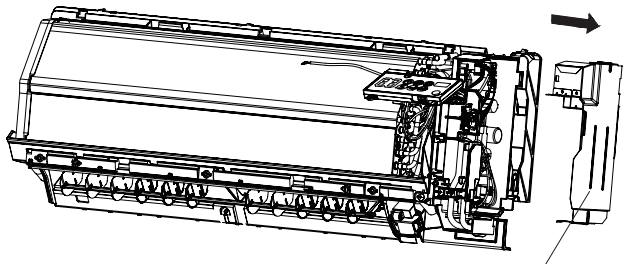
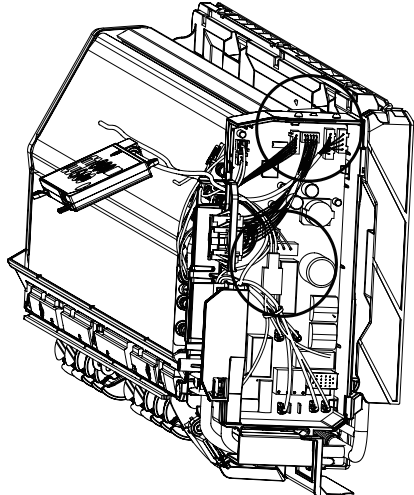
Steps		Procedure
4. Remove electric box		
a	Remove three earthing screws with screws, pull out the indoor tube temperature sensor with hand and then cut off the tileline with scissors.	 <p>temperature sensor</p> <p>earthing screw</p> <p>earthing screw</p>
b	Take out the electric box shielding cover sub-assy.	 <p>shielding cover sub-assy of electric box</p>
5. Remove evaporator		
a	Pull out the power plug from motor and stepping motor.	

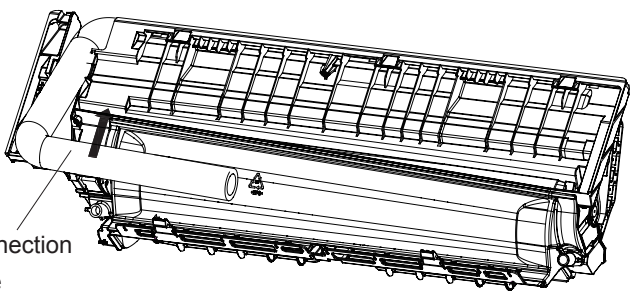
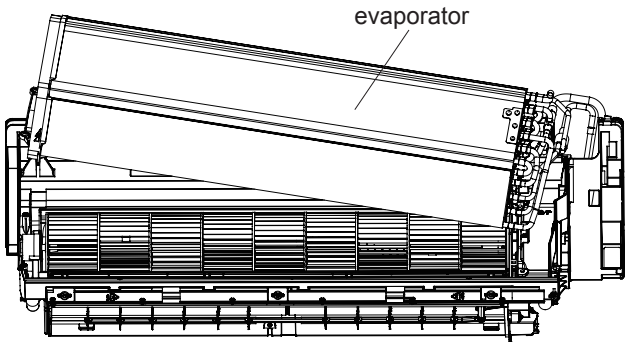
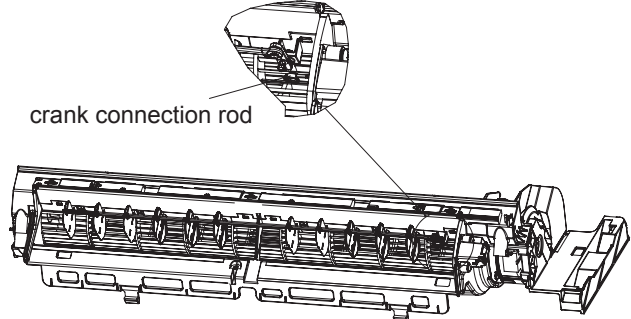
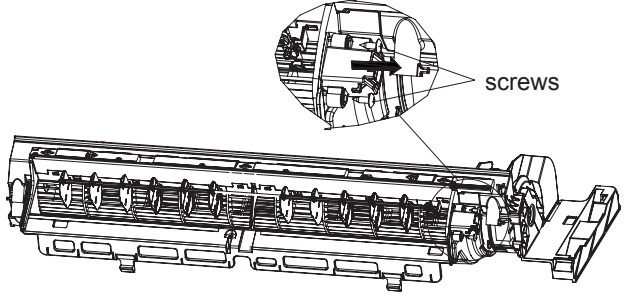
Steps		Procedure
f	Open the connection pipe of evaporator with hand.	 <p>connection pipe</p>
g	Lift up the left end of evaporator with hand, and then take out the evaporator.	 <p>evaporator</p>
6. Remove swing blade		
a	Remove crank connection rod.	 <p>crank connection rod</p>
b	Remove 2 screws fixing swing motor cover with screwdriver.	 <p>screws</p>

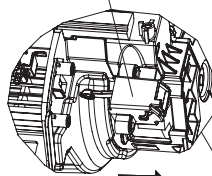
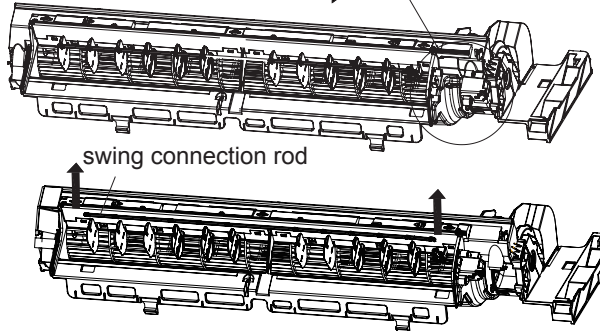
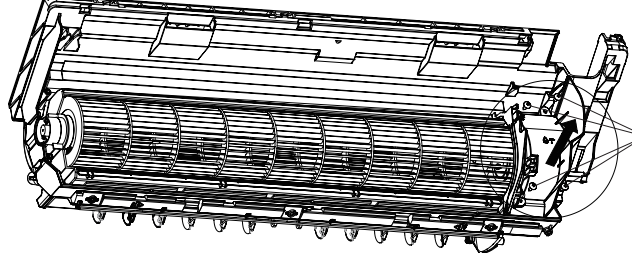
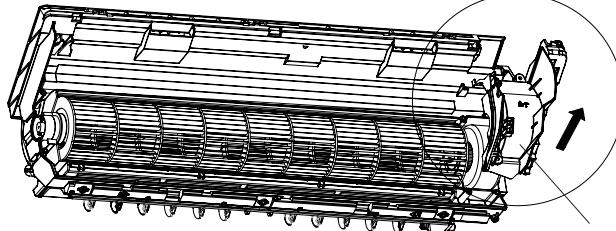
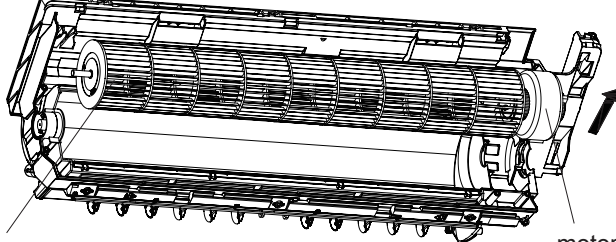
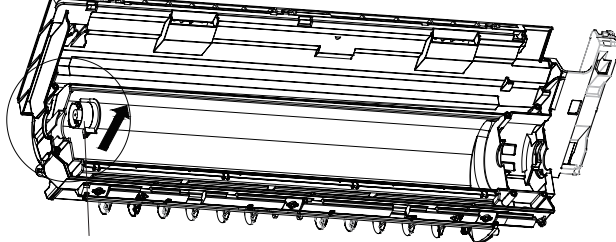
Steps		Procedure
c	Remove swing motor sub-assy.	 <p>swing motor sub-assy</p>
	d	 <p>swing connection rod</p>
7. Remove cross flow blade and motor		
a	Remove 4 screws fixing the motor press plate with screwdriver.	 <p>screws</p>
b	Take out the motor press plate.	 <p>motor press plate</p>
c	Take out cross flow blade and motor.	 <p>cross flow blade</p> <p>motor</p>
d	Pull out the shaft rubber cushion block with hand.	 <p>shaft rubber cushion block</p>

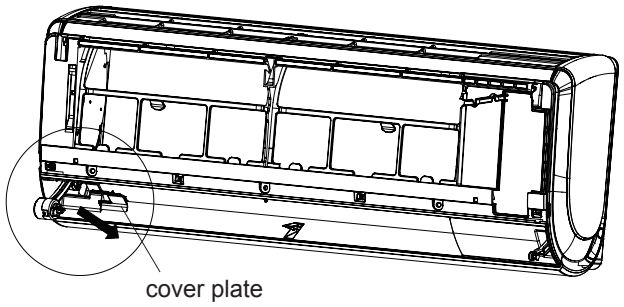
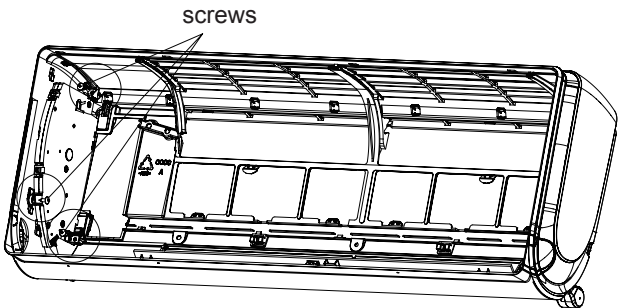
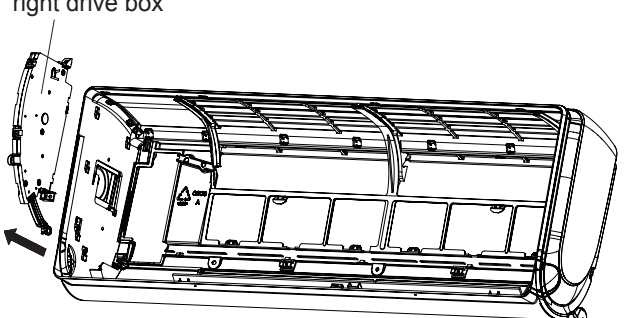
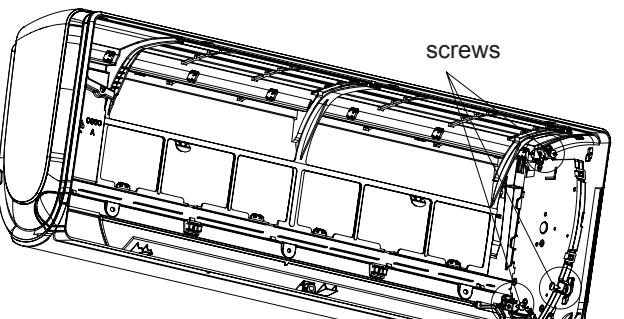
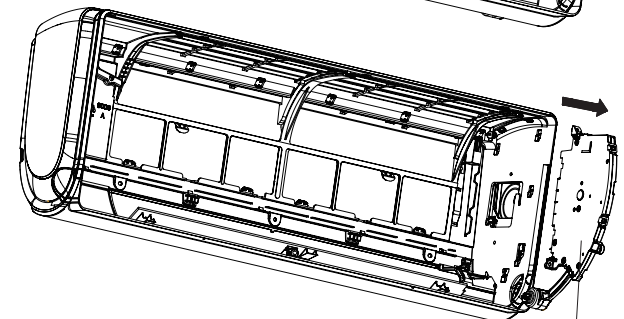
Steps	Procedure	Procedure
8. Remove drive box		 <p>cover plate</p>  <p>screws</p>  <p>right drive box</p>  <p>screws</p>  <p>left drive box</p>

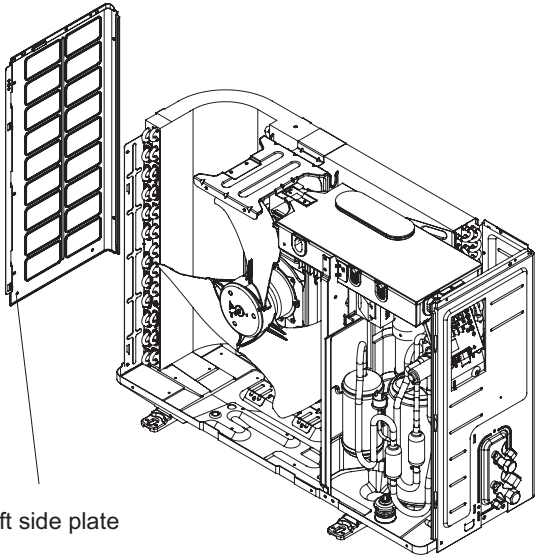
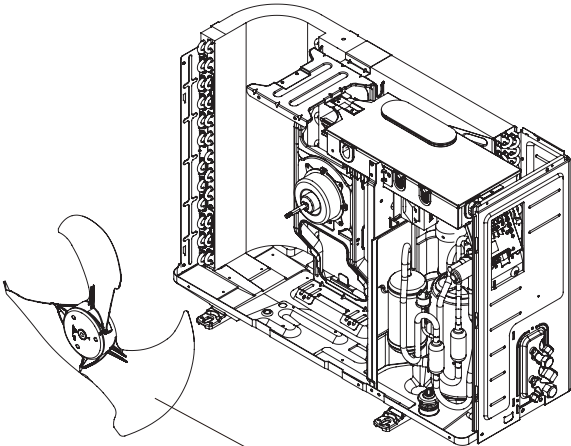
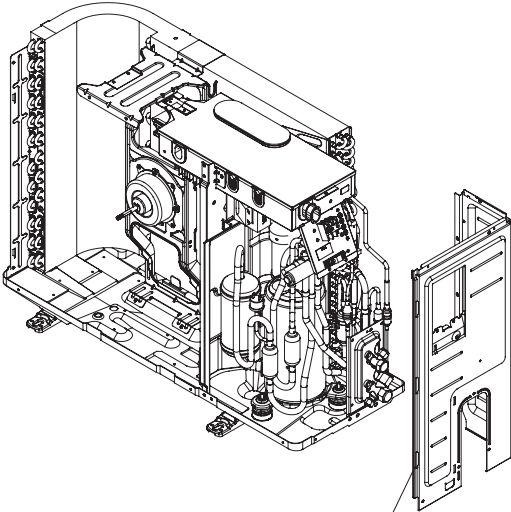
Steps	Procedure
<p>4. Remove left side plate</p>	<p>Remove the screws fixing left side plate and condenser support board, to remove the left side plate.</p>  <p>left side plate</p>
<p>5. Remove cross fan blade</p>	<p>Remove the screw nut fixing cross fan blade, remove the gasket and spring cushion, to remove the cross fan blade.</p>  <p>cross fan blade</p>
<p>6. Remove right side plate</p>	<p>Remove the screws fixing right side plate and valve support, to remove the right side plate.</p>  <p>right side plate</p>

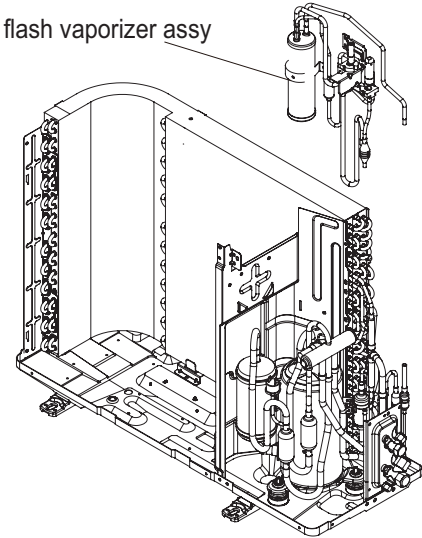
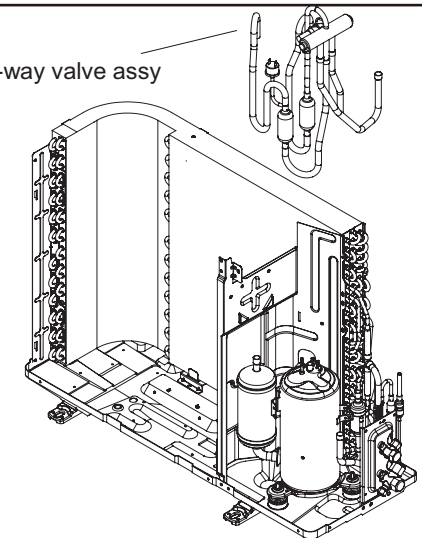
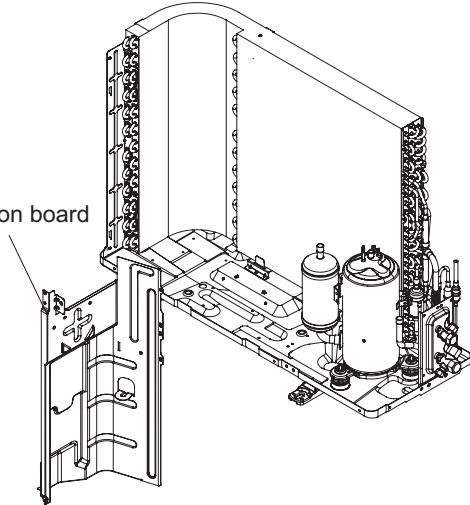
Steps	Procedure
<p>10. Remove flash vaporizer assy</p>	<p>Remove the screws connecting mid-isolation board, lift to remove the flash vaporizer assy.</p> 
<p>11. Remove four-way valve assy</p>	<p>Welding cut the spot weld of four-way valve assy, compressor air suction/discharging valve and condenser pipe outlet, lift to remove the four-way valve assy. (Note: release the refrigerant before welding cutting.)</p> 
<p>12. Remove mid-isolation board</p>	<p>Remove the screws connecting mid-isolation board, chassis and condenser assy, to remove the mid-isolation.</p> 

18K

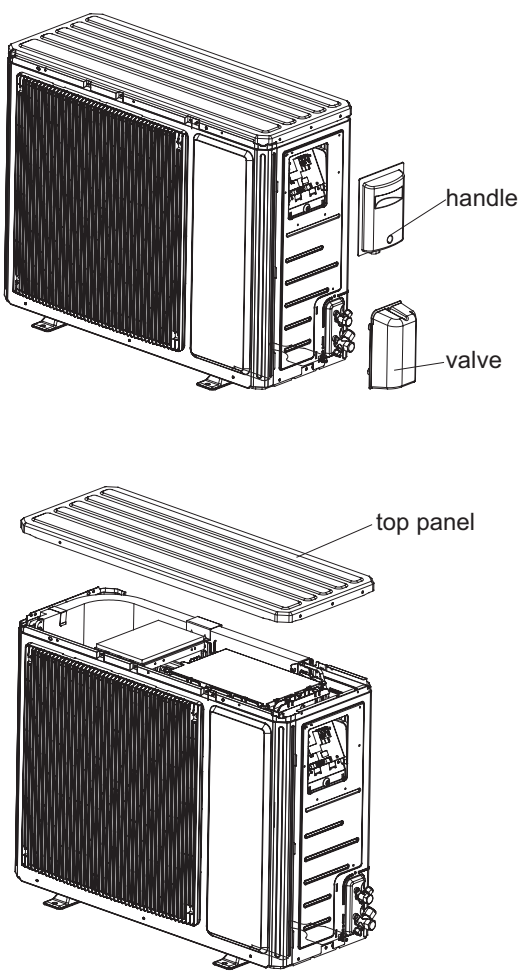
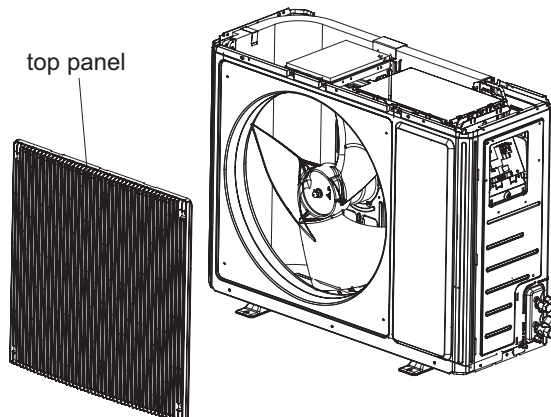
Steps	Procedure
<p>1. Remove top panel</p> <p>1 Twist off the screws used for fixing the handle and valve cover, pull the handle and valve cover upward to remove it.</p> <p>2 Remove the 3 screws connecting the top panel with the front panel and the right side plate, and then remove the top panel.</p>	 <p>The diagram illustrates the removal of the top panel in two stages. In the first stage, the handle and valve cover are shown being removed from the front panel. In the second stage, the top panel is shown being lifted off the main unit, revealing the internal components.</p>
<p>2. Remove grille , panel and rear grill</p> <p>1 Remove the 2 screws connecting the grille and the panel, and then remove the grille.</p>	 <p>The diagram shows the grille being removed from the front panel. The grille is shown being lifted off, revealing the fan and internal components.</p>

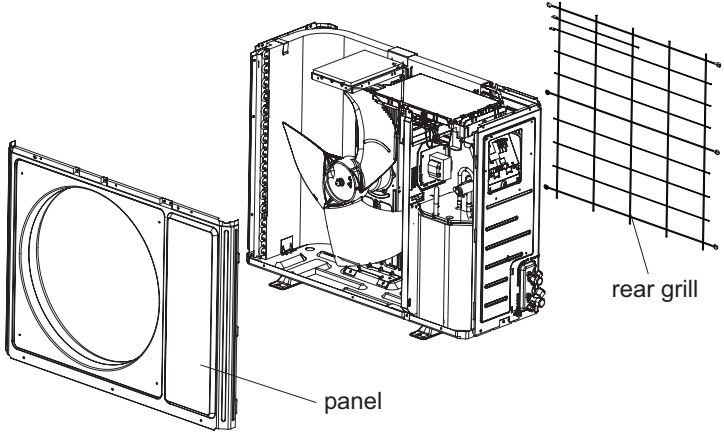
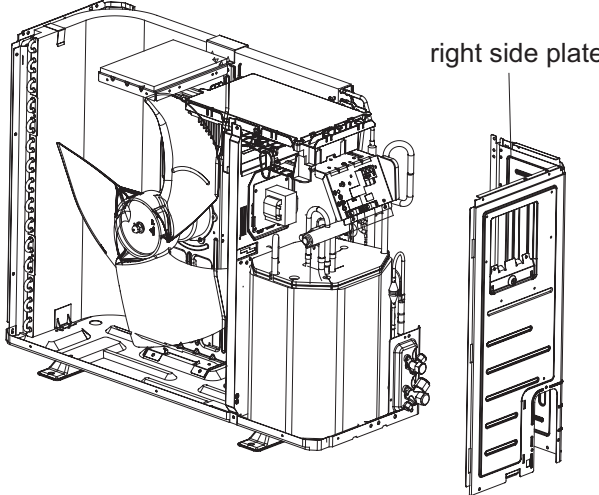
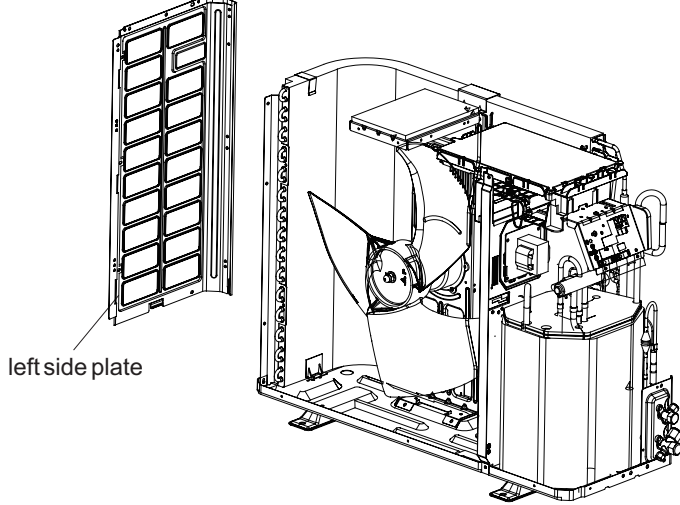
Steps	Procedure	
<p>2</p>	<p>Remove the 5 screws connecting the panel with the chassis and the motor support, and then remove the panel.</p> <p>Remove the 6 screws connecting the left side plate and right side plate and then remove rear grill</p>	
<p>3. Remove left side plate and right side plate</p>		
<p>1</p>	<p>Remove the screws connecting the right side plate with the chassis, the valve support and the electric box, and then remove the right side plate assy.</p>	 
<p>2</p>	<p>Remove the screws connecting the left side plate and the chassis, and then remove the left side plate assy.</p>	

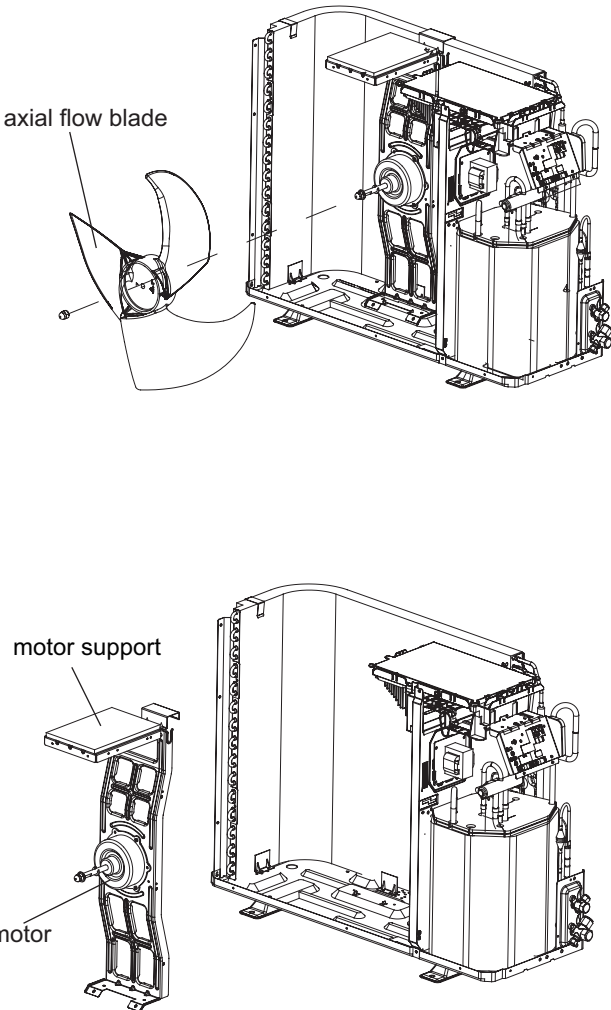
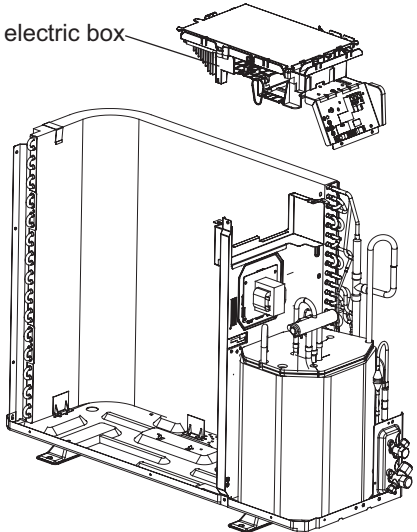
Steps	Procedure	
<p>4. Remove fan motor</p> <p>1</p> <p>2</p>	<p>Remove the nuts fixing the blade and then remove the axial flow blade.</p> <p>Remove the 4 tapping screws fixing the motor; disconnect the leading wire insert of the motor and then remove the motor. Remove the 2 tapping screws fixing the motor support and then pull the motor support upwards to remove it.</p>	 <p>The diagram illustrates the removal of the fan motor in two stages. In the first stage, the axial flow blade is shown being detached from the motor shaft. In the second stage, the motor support is shown being pulled upwards from the motor housing. Labels include 'axial flow blade', 'motor support', and 'motor'.</p>
<p>5. Remove electric box</p>	<p>Remove the screws fixing the electric box sub-assy; loosen the wire bundle; pull out the wiring terminals and then pull the electric box upwards to remove it.</p>	 <p>The diagram shows the electric box sub-assembly being pulled upwards and away from the fan unit. A label 'electric box' points to the sub-assembly.</p>

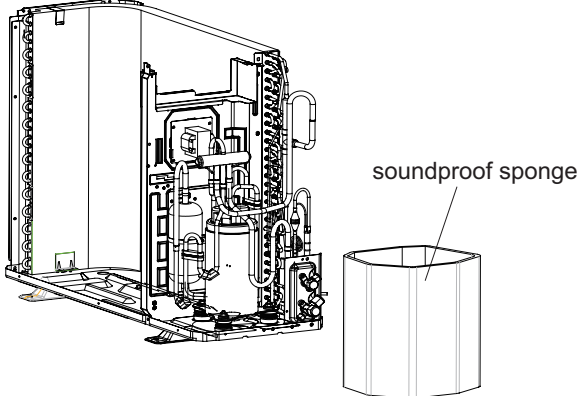
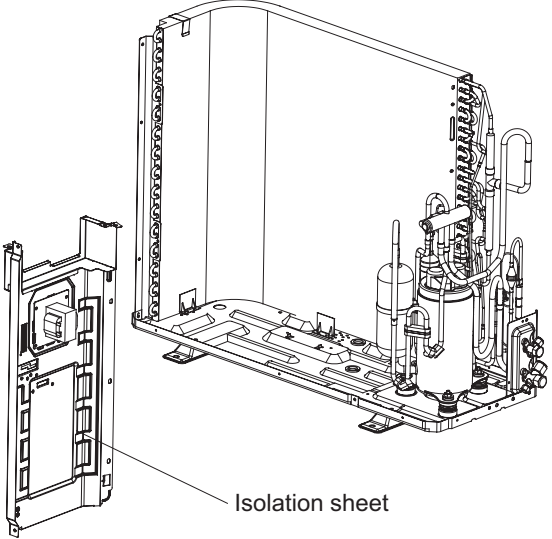
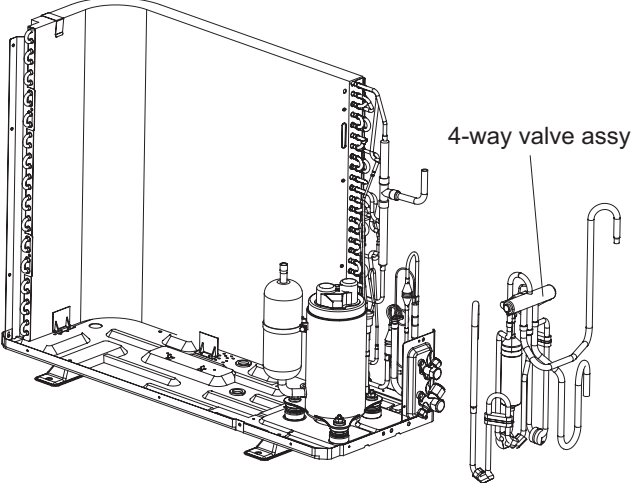
Steps	Procedure
<p>6.Remove soundproof sponge</p>	<p>Since the piping ports on the soundproof sponge are torn easily, remove the soundproof sponge carefully</p>  <p>soundproof sponge</p>
<p>7. Remove Isolation sheet</p>	<p>Remove the 3 screws fixing the isolation sheet and then remove the Isolation sheet.</p>  <p>Isolation sheet</p>
<p>8. Remove 4-way valve assy</p>	<p>Discharge the refrigerant completely;unsolder the pipelines connecting the compressor and the condenser assy,and then remove the 4-way valve assy.</p>  <p>4-way valve assy</p>

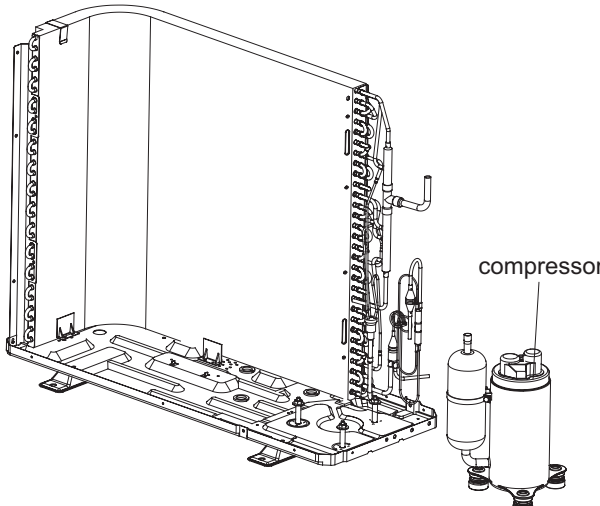
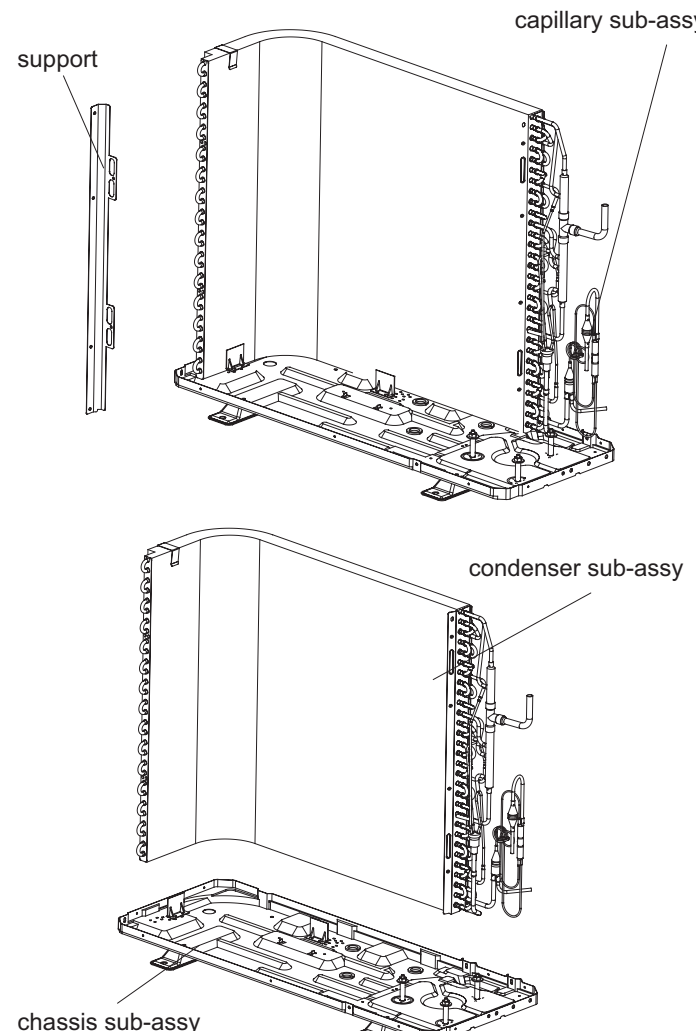
Steps	Procedure	Procedure
9. Remove compressor	Remove the 3 foot nuts fixing the compressor and then remove the compressor.	 <p>compressor</p>
10. Remove condenser sub-assy	<p>1 Remove the screws connecting the support (condenser) and condenser assy, and then remove the support (condenser).</p> <p>2 Remove the chassis sub-assy and condenser sub-assy.</p>	 <p>support</p> <p>capillary sub-assy</p> <p>condenser sub-assy</p> <p>chassis sub-assy</p>

Appendix:

Appendix 1: Reference Sheet of Celsius and Fahrenheit

Conversion formula for Fahrenheit degree and Celsius degree: $T_f = T_c \times 1.8 + 32$

Set temperature

Fahrenheit display temperature (°F)	Fahrenheit (°F)	Celsius(°C)	Fahrenheit display temperature (°F)	Fahrenheit (°F)	Celsius(°C)	Fahrenheit display temperature (°F)	Fahrenheit (°F)	Celsius(°C)
61	60.8	16	69/70	69.8	21	78/79	78.8	26
62/63	62.6	17	71/72	71.6	22	80/81	80.6	27
64/65	64.4	18	73/74	73.4	23	82/83	82.4	28
66/67	66.2	19	75/76	75.2	24	84/85	84.2	29
68	68	20	77	77	25	86	86	30

Ambient temperature

Fahrenheit display temperature (°F)	Fahrenheit (°F)	Celsius(°C)	Fahrenheit display temperature (°F)	Fahrenheit (°F)	Celsius(°C)	Fahrenheit display temperature (°F)	Fahrenheit (°F)	Celsius(°C)
32/33	32	0	55/56	55.4	13	79/80	78.8	26
34/35	33.8	1	57/58	57.2	14	81	80.6	27
36	35.6	2	59/60	59	15	82/83	82.4	28
37/38	37.4	3	61/62	60.8	16	84/85	84.2	29
39/40	39.2	4	63	62.6	17	86/87	86	30
41/42	41	5	64/65	64.4	18	88/89	87.8	31
43/44	42.8	6	66/67	66.2	19	90	89.6	32
45	44.6	7	68/69	68	20	91/92	91.4	33
46/47	46.4	8	70/71	69.8	21	93/94	93.2	34
48/49	48.2	9	72	71.6	22	95/96	95	35
50/51	50	10	73/74	73.4	23	97/98	96.8	36
52/53	51.8	11	75/76	75.2	24	99	98.6	37
54	53.6	12	77/78	77	25			

Appendix 2: Configuration of Connection Pipe

1. Standard length of connection pipe

- 5m, 7.5m, 8m.

2. Min. length of connection pipe is 3m.

3. Max. length of connection pipe and max. high difference.

4. The additional refrigerant oil and refrigerant charging required after prolonging connection pipe

- After the length of connection pipe is prolonged for 10m at the basis of standard length, you should add 5ml of refrigerant oil for each additional 5m of connection pipe.

- The calculation method of additional refrigerant charging amount (on the basis of liquid pipe):

Cooling capacity	Max length of connection pipe	Max height difference
5000 Btu/h(1465 W)	15 m	5 m
7000 Btu/h(2051 W)	15 m	5 m
9000 Btu/h(2637 W)	15 m	10 m
12000 Btu/h(3516 W)	20 m	10 m
18000 Btu/h(5274 W)	25 m	10 m
24000 Btu/h(7032 W)	25 m	10 m
28000 Btu/h(8204 W)	30 m	10 m
36000 Btu/h(10548 W)	30 m	20 m
42000 Btu/h(12306 W)	30 m	20 m
48000 Btu/h(14064 W)	30 m	20 m

- When the length of connection pipe is above 5m, add refrigerant according to the prolonged length of liquid pipe. The additional refrigerant charging amount per meter is different according to the diameter of liquid pipe. See the following sheet.

- Additional refrigerant charging amount = prolonged length of liquid pipe X additional refrigerant charging amount per meter

Additional refrigerant charging amount for R22, R407C, R410A and R134a			
Diameter of connection pipe		Outdoor unit throttle	
Liquid pipe(mm)	Gas pipe(mm)	Cooling only(g/m)	Cooling and heating(g/m)
Φ6	Φ9.5 or Φ12	15	20
Φ6 or Φ9.5	Φ16 or Φ19	15	20
Φ12	Φ19 or Φ22.2	30	120
Φ16	Φ25.4 or Φ31.8	60	120
Φ19	/	250	250
Φ22.2	/	350	350

Appendix 4: List of Resistance for Temperature Sensor

Resistance Table of Ambient Temperature Sensor for Indoor and Outdoor Units(15K)

Temp(°C)	Resistance(kΩ)	Temp(°C)	Resistance(kΩ)	Temp(°C)	Resistance(kΩ)	Temp(°C)	Resistance(kΩ)
-19	138.1	20	18.75	59	3.848	98	1.071
-18	128.6	21	17.93	60	3.711	99	1.039
-17	121.6	22	17.14	61	3.579	100	1.009
-16	115	23	16.39	62	3.454	101	0.98
-15	108.7	24	15.68	63	3.333	102	0.952
-14	102.9	25	15	64	3.217	103	0.925
-13	97.4	26	14.36	65	3.105	104	0.898
-12	92.22	27	13.74	66	2.998	105	0.873
-11	87.35	28	13.16	67	2.896	106	0.848
-10	82.75	29	12.6	68	2.797	107	0.825
-9	78.43	30	12.07	69	2.702	108	0.802
-8	74.35	31	11.57	70	2.611	109	0.779
-7	70.5	32	11.09	71	2.523	110	0.758
-6	66.88	33	10.63	72	2.439	111	0.737
-5	63.46	34	10.2	73	2.358	112	0.717
-4	60.23	35	9.779	74	2.28	113	0.697
-3	57.18	36	9.382	75	2.206	114	0.678
-2	54.31	37	9.003	76	2.133	115	0.66
-1	51.59	38	8.642	77	2.064	116	0.642
0	49.02	39	8.297	78	1.997	117	0.625
1	46.6	40	7.967	79	1.933	118	0.608
2	44.31	41	7.653	80	1.871	119	0.592
3	42.14	42	7.352	81	1.811	120	0.577
4	40.09	43	7.065	82	1.754	121	0.561
5	38.15	44	6.791	83	1.699	122	0.547
6	36.32	45	6.529	84	1.645	123	0.532
7	34.58	46	6.278	85	1.594	124	0.519
8	32.94	47	6.038	86	1.544	125	0.505
9	31.38	48	5.809	87	1.497	126	0.492
10	29.9	49	5.589	88	1.451	127	0.48
11	28.51	50	5.379	89	1.408	128	0.467
12	27.18	51	5.197	90	1.363	129	0.456
13	25.92	52	4.986	91	1.322	130	0.444
14	24.73	53	4.802	92	1.282	131	0.433
15	23.6	54	4.625	93	1.244	132	0.422
16	22.53	55	4.456	94	1.207	133	0.412
17	21.51	56	4.294	95	1.171	134	0.401
18	20.54	57	4.139	96	1.136	135	0.391
19	19.63	58	3.99	97	1.103	136	0.382

Resistance Table of Tube Temperature Sensors for Indoor and Outdoor (20K)

Temp(°C)	Resistance(kΩ)	Temp(°C)	Resistance(kΩ)	Temp(°C)	Resistance(kΩ)	Temp(°C)	Resistance(kΩ)
-19	181.4	20	25.01	59	5.13	98	1.427
-18	171.4	21	23.9	60	4.948	99	1.386
-17	162.1	22	22.85	61	4.773	100	1.346
-16	153.3	23	21.85	62	4.605	101	1.307
-15	145	24	20.9	63	4.443	102	1.269
-14	137.2	25	20	64	4.289	103	1.233
-13	129.9	26	19.14	65	4.14	104	1.198
-12	123	27	18.13	66	3.998	105	1.164
-11	116.5	28	17.55	67	3.861	106	1.131
-10	110.3	29	16.8	68	3.729	107	1.099
-9	104.6	30	16.1	69	3.603	108	1.069
-8	99.13	31	15.43	70	3.481	109	1.039
-7	94	32	14.79	71	3.364	110	1.01
-6	89.17	33	14.18	72	3.252	111	0.983
-5	84.61	34	13.59	73	3.144	112	0.956
-4	80.31	35	13.04	74	3.04	113	0.93
-3	76.24	36	12.51	75	2.94	114	0.904
-2	72.41	37	12	76	2.844	115	0.88
-1	68.79	38	11.52	77	2.752	116	0.856
0	65.37	39	11.06	78	2.663	117	0.833
1	62.13	40	10.62	79	2.577	118	0.811
2	59.08	41	10.2	80	2.495	119	0.777
3	56.19	42	9.803	81	2.415	120	0.769
4	53.46	43	9.42	82	2.339	121	0.746
5	50.87	44	9.054	83	2.265	122	0.729
6	48.42	45	8.705	84	2.194	123	0.71
7	46.11	46	8.37	85	2.125	124	0.692
8	43.92	47	8.051	86	2.059	125	0.674
9	41.84	48	7.745	87	1.996	126	0.658
10	39.87	49	7.453	88	1.934	127	0.64
11	38.01	50	7.173	89	1.875	128	0.623
12	36.24	51	6.905	90	1.818	129	0.607
13	34.57	52	6.648	91	1.736	130	0.592
14	32.98	53	6.403	92	1.71	131	0.577
15	31.47	54	6.167	93	1.658	132	0.563
16	30.04	55	5.942	94	1.609	133	0.549
17	28.68	56	5.726	95	1.561	134	0.535
18	27.39	57	5.519	96	1.515	135	0.521
19	26.17	58	5.32	97	1.47	136	0.509

Resistance Table of Discharge Temperature Sensor for Outdoor(50K)

Temp(°C)	Resistance(kΩ)	Temp(°C)	Resistance(kΩ)	Temp(°C)	Resistance(kΩ)	Temp(°C)	Resistance(kΩ)
-29	853.5	10	98	49	18.34	88	4.754
-28	799.8	11	93.42	50	17.65	89	4.609
-27	750	12	89.07	51	16.99	90	4.469
-26	703.8	13	84.95	52	16.36	91	4.334
-25	660.8	14	81.05	53	15.75	92	4.204
-24	620.8	15	77.35	54	15.17	93	4.079
-23	580.6	16	73.83	55	14.62	94	3.958
-22	548.9	17	70.5	56	14.09	95	3.841
-21	516.6	18	67.34	57	13.58	96	3.728
-20	486.5	19	64.33	58	13.09	97	3.619
-19	458.3	20	61.48	59	12.62	98	3.514
-18	432	21	58.77	60	12.17	99	3.413
-17	407.4	22	56.19	61	11.74	100	3.315
-16	384.5	23	53.74	62	11.32	101	3.22
-15	362.9	24	51.41	63	10.93	102	3.129
-14	342.8	25	49.19	64	10.54	103	3.04
-13	323.9	26	47.08	65	10.18	104	2.955
-12	306.2	27	45.07	66	9.827	105	2.872
-11	289.6	28	43.16	67	9.489	106	2.792
-10	274	29	41.34	68	9.165	107	2.715
-9	259.3	30	39.61	69	8.854	108	2.64
-8	245.6	31	37.96	70	8.555	109	2.568
-7	232.6	32	36.38	71	8.268	110	2.498
-6	220.5	33	34.88	72	7.991	111	2.431
-5	209	34	33.45	73	7.726	112	2.365
-4	198.3	35	32.09	74	7.47	113	2.302
-3	199.1	36	30.79	75	7.224	114	2.241
-2	178.5	37	29.54	76	6.998	115	2.182
-1	169.5	38	28.36	77	6.761	116	2.124
0	161	39	27.23	78	6.542	117	2.069
1	153	40	26.15	79	6.331	118	2.015
2	145.4	41	25.11	80	6.129	119	1.963
3	138.3	42	24.13	81	5.933	120	1.912
4	131.5	43	23.19	82	5.746	121	1.863
5	125.1	44	22.29	83	5.565	122	1.816
6	119.1	45	21.43	84	5.39	123	1.77
7	113.4	46	20.6	85	5.222	124	1.725
8	108	47	19.81	86	5.06	125	1.682
9	102.8	48	19.06	87	4.904	126	1.64

Note: The information above is for reference only.

JF00302343



GREE ELECTRIC APPLIANCES, INC. OF ZHUHAI

Add: West Jinji Rd, Qianshan, Zhuhai, Guangdong, China 519070

Tel: (+86-756) 8522218 Fax: (+86-756) 8669426

Email: gree@gree.com.cn [Http://www.gree.com](http://www.gree.com)

HONG KONG GREE ELECTRIC APPLIANCES SALES LIMITED

Add: Unit 2612,26/F.,Miramar Tower 132 Nathan Road,TST,Kowloon,HK

Tel: (852) 31658898 Fax: (852) 31651029

For product improvement, specifications and appearance in this manual are subject to change without prior notice.