



# AZURI<sup>®</sup>

## SERVICE MANUAL



DELTRON<sup>®</sup>

# Table of Contents

<b>Part I : Technical Information</b> .....	<b>1</b>
<b>1. Summary</b> .....	<b>1</b>
<b>2. Specifications</b> .....	<b>2</b>
2.1 Specification Sheet.....	2
2.2 Capacity Variation Ratio According to Temperature .....	6
<b>3. Outline Dimension Diagram</b> .....	<b>7</b>
3.1 Indoor Unit.....	7
3.2 Outdoor Unit.....	8
<b>4. Refrigerant System Diagram</b> .....	<b>10</b>
<b>5. Electrical Part</b> .....	<b>11</b>
5.1 Wiring Diagram.....	11
5.2 PCB Printed Diagram.....	14
<b>6. Function and Control</b> .....	<b>17</b>
6.1 Remote Controller Introduction.....	17
6.2 Brief Description of Modes and Functions.....	21
6.3 GREE+ App Operation Manual.....	23
6.4 Ewpe Smart App Operation Manual .....	24
<b>Part II : Installation and Maintenance</b> .....	<b>25</b>
<b>7. Notes for Installation and Maintenance</b> .....	<b>25</b>
<b>8. Installation</b> .....	<b>33</b>
8.1 Requirements for Electric Connection.....	33
8.2 Installation of indoor unit.....	33
8.3 Outdoor Unit Installation .....	38
8.4 Vacuum Pumping and Leak Detection .....	38
8.5 Check after Installation and Test Operation .....	39
<b>9. Maintenance</b> .....	<b>40</b>

9.1 Error Code List.....	40
9.2 Procedure of Troubleshooting.....	46
9.3 Troubleshooting for Normal Malfunction.....	58
<b>10. Exploded View and Parts List.....</b>	<b>60</b>
10.1 Indoor Unit.....	60
10.2 Outdoor Unit.....	62
<b>11. Removal Procedure.....</b>	<b>65</b>
11.1 Removal Procedure of Indoor Unit.....	65
11.2 Removal Procedure of Outdoor Unit.....	69
<b>Appendix:.....</b>	<b>83</b>
Appendix 1: Reference Sheet of Celsius and Fahrenheit.....	83
Appendix 2: Configuration of Connection Pipe.....	83
Appendix 3: Pipe Expanding Method.....	84
Appendix 4: List of Resistance for Temperature Sensor.....	85

# 1. Summary

## Indoor Unit:

AZI-FO25VE/I  
AZI-FO35VE/I  
AZI-FO50VE/I



## Outdoor Unit:

AZI-FO25VE/O



AZI-FO35VE/O

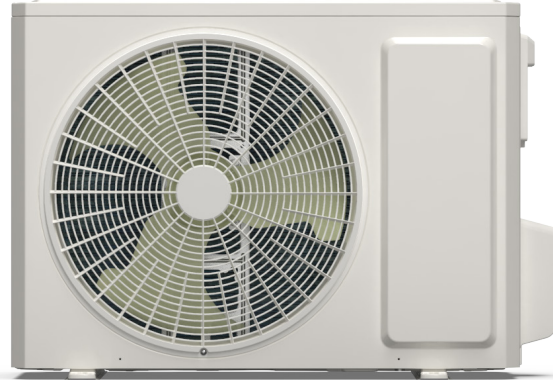

AZI-FO50VE/O

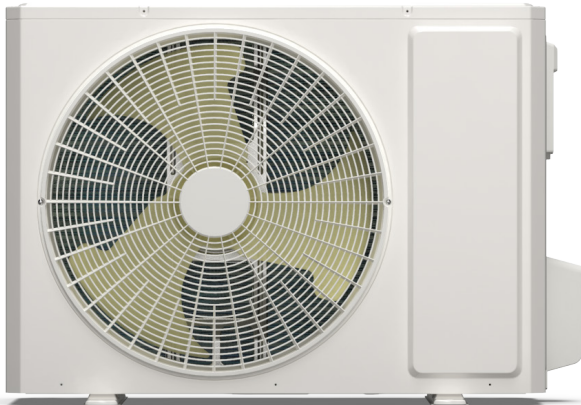

## Remote Controller:

YAA1FB8(WiFi)



# 2. Specifications

## 2.1 Specification Sheet

Model			AZI-FO25VE	AZI-FO35VE
Product Code			CV010003100	CV010003200
Power Supply	Rated Voltage	V~	220-240	220-240
	Rated Frequency	Hz	50	50
	Phases		1	1
Power Supply Mode			Outdoor	Outdoor
Cooling Capacity		W	2700	3520
Heating Capacity		W	2900	3800
Cooling Power Input		W	700	926
Heating Power Input		W	730	960
Cooling Power Current		A	3.5	4.6
Heating Power Current		A	3.5	4.6
Rated Input		W	1200	1700
Rated Cooling Current		A	5.5	7
Rated Heating Current		A	6	7.5
Air Flow Volume		m <sup>3</sup> /h	500/430/410/370/330/280/250	600/520/480/440/400/360/280
Dehumidifying Volume		L/h	0.8	1.2
EER		W/W	3.86	3.8
COP		W/W	3.97	3.96
SEER			7.8	7.2
HSPF			/	/
Application Area		m <sup>2</sup>	12-18	16-24
Indoor Unit	Model of indoor unit		AZI-FO25VE/I	AZI-FO35VE/I
	Indoor Unit Product Code		CV010N03100	CV010N03200
	Fan Type		Centrifugal	Centrifugal
	Fan Diameter Length(DXL)		mm	Φ370×80
	Cooling Speed		r/min	Turn on the upper air louver: 650/560/530/480/430/370/320 Turn off the lower air louver: 620/530/500/450/400/340/290
	Heating Speed		r/min	Turn on the upper air louver: 650/560/530/480/430/370/320 Turn off the lower air louver: 620/530/500/450/400/340/290
	Fan Motor Power Output		W	30
	Fan Motor RLA		A	0.15
	Fan Motor Capacitor		μF	/
	Evaporator Form			Aluminum Fin-copper Tube
	Evaporator Pipe Diameter		mm	Φ7
	Evaporator Row-fin Gap		mm	2-1.3
	Evaporator Coil Length (LXDXW)		mm	511×400×25.4
	Swing Motor Model			MP24EB/MP24AE
	Swing Motor Power Output		W	1.5/1.5
	Fuse Current		A	3.15
	Sound Pressure Level		dB (A)	Cooling:39/36/34/32/29/26/23 Heating:39/36/34/32/29/25/22
	Sound Power Level		dB (A)	Cooling:52/48/46/44/41/38/35 Heating:52/48/46/44/41/37/34
	Dimension (WXHXD)		mm	700X600X215
	Dimension of Carton Box (LXWXH)		mm	785X280X682
	Dimension of Package (LXWXH)		mm	788X283X697
Net Weight		kg	15.5	
Gross Weight		kg	18.5	

Outdoor Unit	Outdoor Unit Model		AZI-FO25VE/O	AZI-FO35VE/O
	Outdoor Unit Product Code		CV010W03100	CV010W03200
	Compressor Manufacturer		ZHUHAI LANDA COMPRESSOR CO.,LTD.	ZHUHAI LANDA COMPRESSOR CO.,LTD.
	Compressor Model		QXF-A082zC170	FTz-AN108ACBD
	Compressor Oil		ZE-G;ES RB68GX or equivalent	FW68DA or equivalent
	Compressor Type		Rotary	Rotary
	Compressor LRA.	A	15	/
	Compressor RLA	A	2.56	4.4
	Compressor Power Input	W	757	/
	Compressor Overload Protector		/	/
	Throttling Method		Electron expansion valve	Electron expansion valve
	Set Temperature Range	°C	16~30	16~30
	Cooling Operation Ambient Temperature Range	°C	-15~43	-15~43
	Heating Operation Ambient Temperature Range	°C	-22~24	-22~24
	Condenser Form		Aluminum Fin-copper Tube	Aluminum Fin-copper Tube
	Condenser Pipe Diameter	mm	Φ7	Φ7.94
	Condenser Rows-fin Gap	mm	1-1.2	1-1.2
	Condenser Coil Length (LXDXW)	mm	666×19.05×527	761.5×38.1×528
	Fan Motor Speed	rpm	850	850
	Fan Motor Power Output	W	30	30
	Fan Motor RLA	A	0.4	0.4
	Fan Motor Capacitor	μF	/	/
	Outdoor Unit Air Flow Volume	m <sup>3</sup> /h	1950	2200
	Fan Type		Axial-flow	Axial-flow
	Fan Diameter	mm	Φ400	Φ420
	Defrosting Method		Automatic Defrosting	Automatic Defrosting
	Climate Type		T1	T1
	Isolation		I	I
	Moisture Protection		IPX4	IPX4
	Permissible Excessive Operating Pressure for the Discharge Side	MPa	4.3	4.3
	Permissible Excessive Operating Pressure for the Suction Side	MPa	2.5	2.5
	Sound Pressure Level	dB (A)	51	53
	Sound Power Level	dB (A)	61	63
Dimension(WXHXD)	mm	732X555X330	802X555X350	
Dimension of Carton Box (LXWXH)	mm	791X373X590	869X395X594	
Dimension of Package(LXWXH)	mm	794X376X615	872X398X620	
Net Weight	kg	24	27.5	
Gross Weight	kg	26.5	30	
Refrigerant		R32	R32	
Refrigerant Charge	kg	0.51	0.75	
Connection Pipe	Connection Pipe Length	m	5	5
	Connection Pipe Gas Additional Charge	g/m	16	16
	Outer Diameter Liquid Pipe		1/4"	1/4"
	Outer Diameter Gas Pipe		3/8"	3/8"
	Max Distance Height	m	10	10
	Max Distance Length	m	15	20
Note: The connection pipe applies metric diameter.				

The above data is subject to change without notice; please refer to the nameplate of the unit.

Model			AZI-FO50VE
Product Code			CV010003300
Power Supply	Rated Voltage	V~	220-240
	Rated Frequency	Hz	50
	Phases		1
Power Supply Mode			Outdoor
Cooling Capacity		W	5200
Heating Capacity		W	5330
Cooling Power Input		W	1445
Heating Power Input		W	1545
Cooling Power Current		A	6.6
Heating Power Current		A	7.1
Rated Input		W	2400
Rated Cooling Current		A	11.5
Rated Heating Current		A	11.5
Air Flow Volume		m <sup>3</sup> /h	750/670/600/520/470/430/350
Dehumidifying Volume		L/h	1.8
EER		W/W	3.6
COP		W/W	3.45
SEER			7.2
HSPF			/
Application Area		m <sup>2</sup>	23-34
Indoor Unit	Model of indoor unit		AZI-FO50VE/I
	Indoor Unit Product Code		CV010N03300
	Fan Type		Centrifugal
	Fan Diameter Length(DXL)		mm Φ370×80
	Cooling Speed		r/min Turn on the upper air louver :840/800/720/650/580 /530/410 Turn off the lower air louver:810/770/690/620/550 /500/380
	Heating Speed		r/min Turn on the upper air louver :930/840/760/690/620 /570/480 Turn off the lower air louver:850/800/720/650/580 /530/470
	Fan Motor Power Output		W 30
	Fan Motor RLA		A 0.15
	Fan Motor Capacitor		μF /
	Evaporator Form		Aluminum Fin-copper Tube
	Evaporator Pipe Diameter		mm Φ7
	Evaporator Row-fin Gap		mm 2-1.3
	Evaporator Coil Length (LXDXW)		mm 511×400×25.4
	Swing Motor Model		MP24EB/MP24AE
	Swing Motor Power Output		W 1.5/1.5
	Fuse Current		A 3.15
	Sound Pressure Level		dB (A) Cooling:49/47/45/42/40/37/32 Heating:51/48/45/43/40/38/33
	Sound Power Level		dB (A) Cooling:60/58/56/53/51/48/43 Heating:60/57/54/52/49/47/42
	Dimension (WXHxD)		mm 700X600X215
	Dimension of Carton Box (LXWXH)		mm 785X280X682
Dimension of Package (LXWXH)		mm 788X283X697	
Net Weight		kg 16	
Gross Weight		kg 19	

Outdoor Unit	Outdoor Unit Model		AZI-FO50VE/O
	Outdoor Unit Product Code		CV010W03300
	Compressor Manufacturer		ZHUHAI LANDA COMPRESSOR CO., LTD.
	Compressor Model		QXF-M130zF170
	Compressor Oil		RB68GX or equivalent
	Compressor Type		Rotary
	Compressor LRA.	A	22
	Compressor RLA	A	5.36
	Compressor Power Input	W	1196
	Compressor Overload Protector		/
	Throttling Method		Electron expansion valve
	Set Temperature Range	°C	16~30
	Cooling Operation Ambient Temperature Range	°C	-15~43
	Heating Operation Ambient Temperature Range	°C	-22~24
	Condenser Form		Aluminum Fin-copper Tube
	Condenser Pipe Diameter	mm	Φ7
	Condenser Rows-fin Gap	mm	2-1.4
	Condenser Coil Length (LXDXW)	mm	839×38.1×616
	Fan Motor Speed	rpm	820
	Fan Motor Power Output	W	60
	Fan Motor RLA	A	0.65
	Fan Motor Capacitor	μF	/
	Outdoor Unit Air Flow Volume	m <sup>3</sup> /h	3600
	Fan Type		Axial-flow
	Fan Diameter	mm	Φ520
	Defrosting Method		Automatic Defrosting
	Climate Type		T1
	Isolation		I
	Moisture Protection		IPX4
	Permissible Excessive Operating Pressure for the Discharge Side	MPa	4.3
	Permissible Excessive Operating Pressure for the Suction Side	MPa	2.5
	Sound Pressure Level	dB (A)	59
Sound Power Level	dB (A)	65	
Dimension(WXHxD)	mm	958X660X402	
Dimension of Carton Box (LXWXH)	mm	1029X453X715	
Dimension of Package(LXWXH)	mm	1032X456X737	
Net Weight	kg	41	
Gross Weight	kg	45.5	
Refrigerant		R32	
Refrigerant Charge	kg	1	
Connection Pipe	Connection Pipe Length	m	5
	Connection Pipe Gas Additional Charge	g/m	16
	Outer Diameter Liquid Pipe		1/4"
	Outer Diameter Gas Pipe		1/2"
	Max Distance Height	m	10
	Max Distance Length	m	25
Note: The connection pipe applies metric diameter.			

The above data is subject to change without notice; please refer to the nameplate of the unit.



## 2.2 Capacity Variation Ratio According to Temperature

25/35

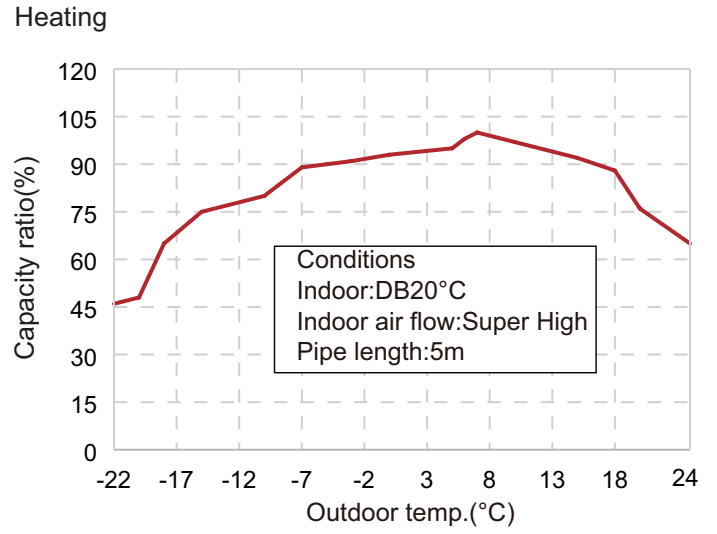
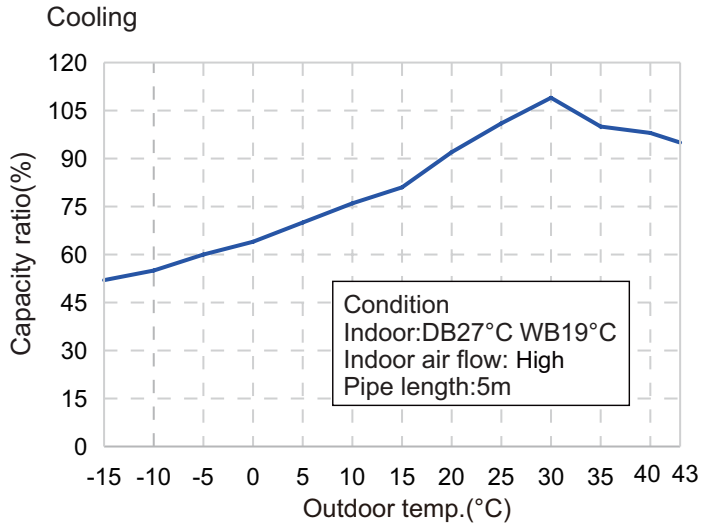

50

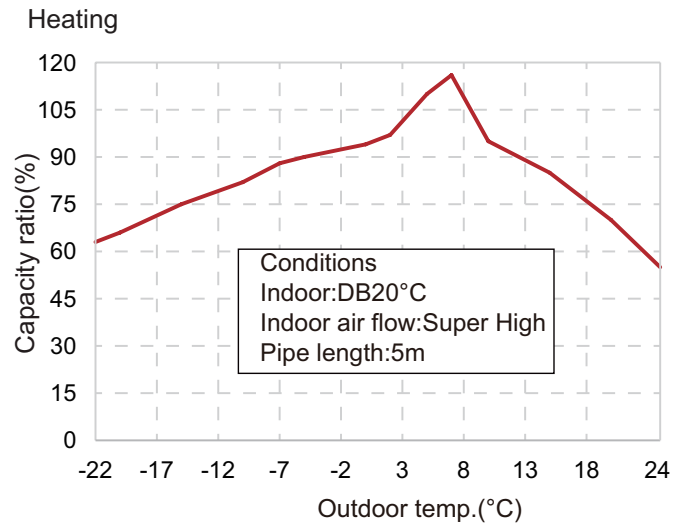
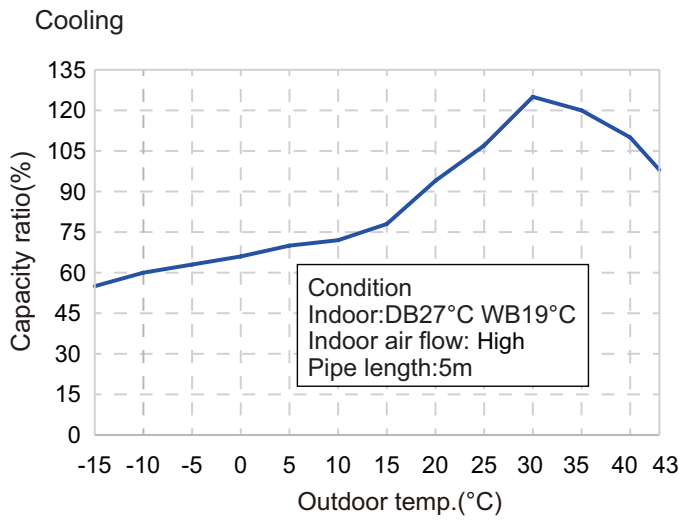

# 3. Outline Dimension Diagram

## 3.1 Indoor Unit

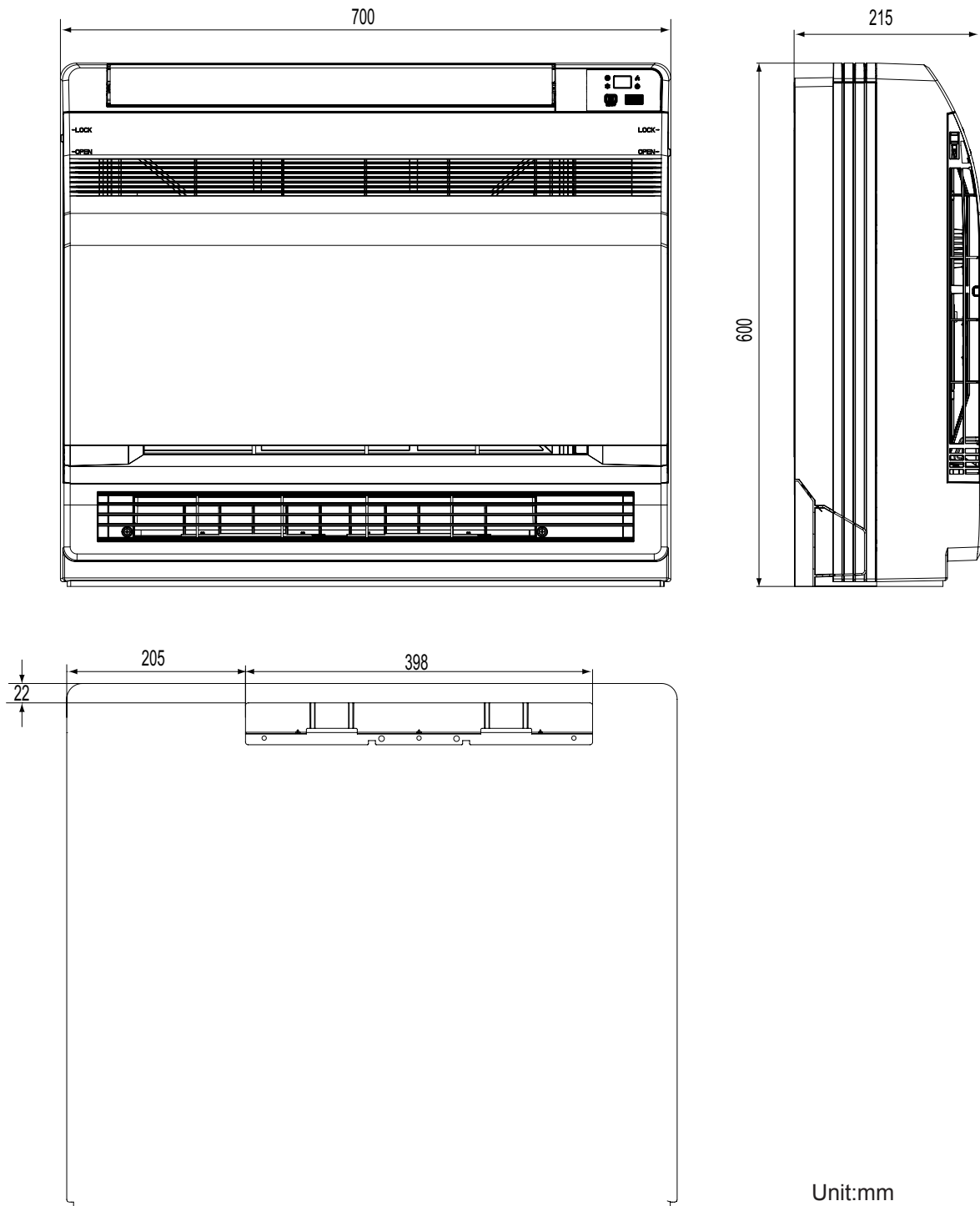

## 3.2 Outdoor Unit

AZI-FO25VE/O

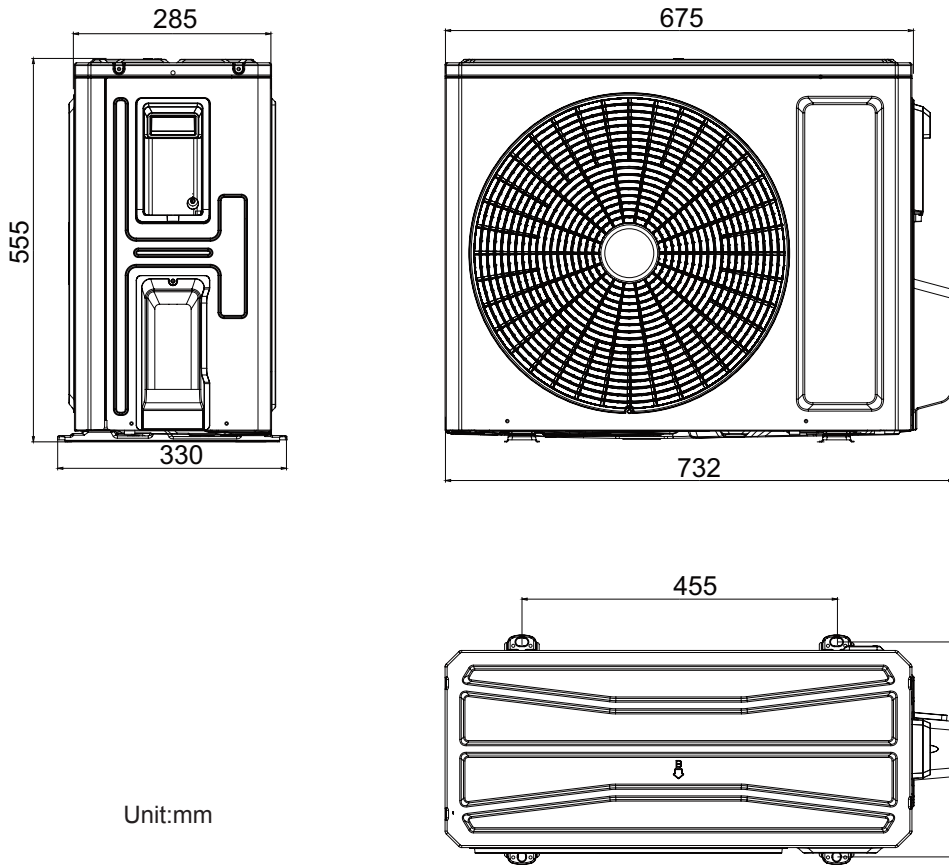

AZI-FO35VE/O

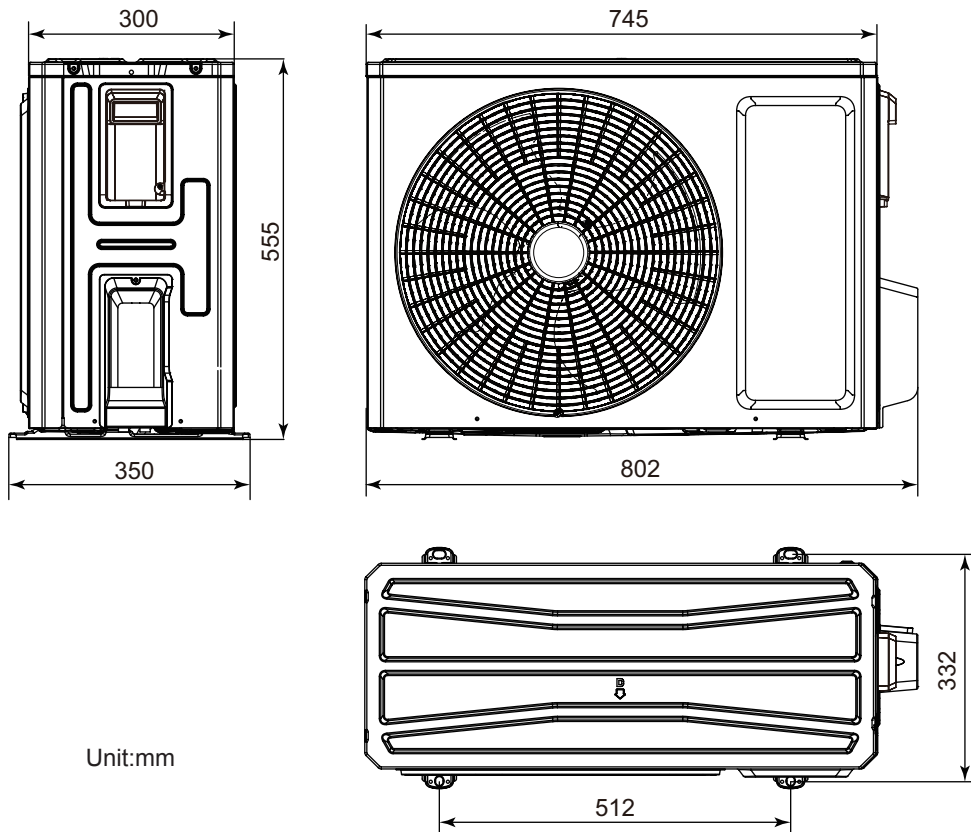

AZI-FO50VE/O

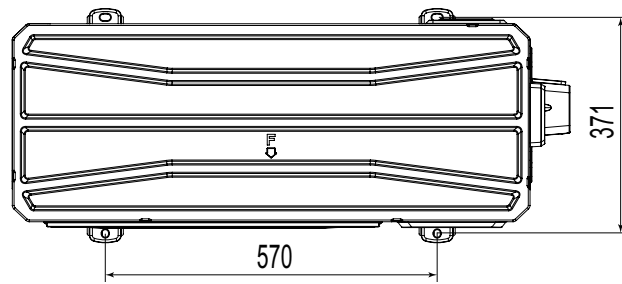
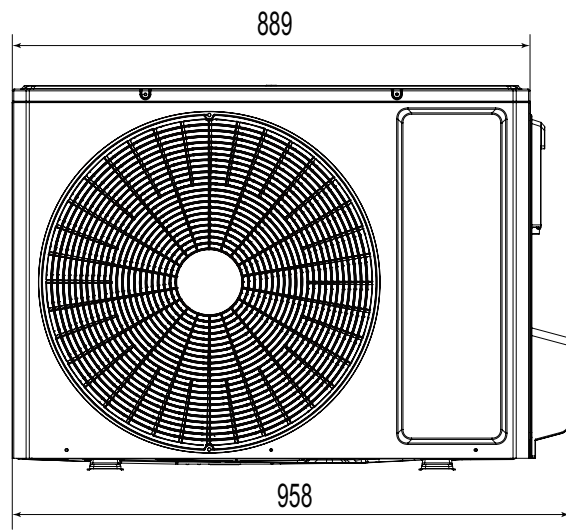
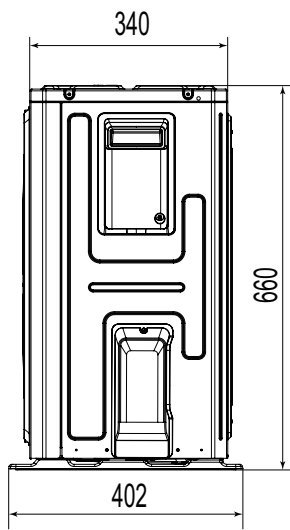

Unit:mm

# 4. Refrigerant System Diagram

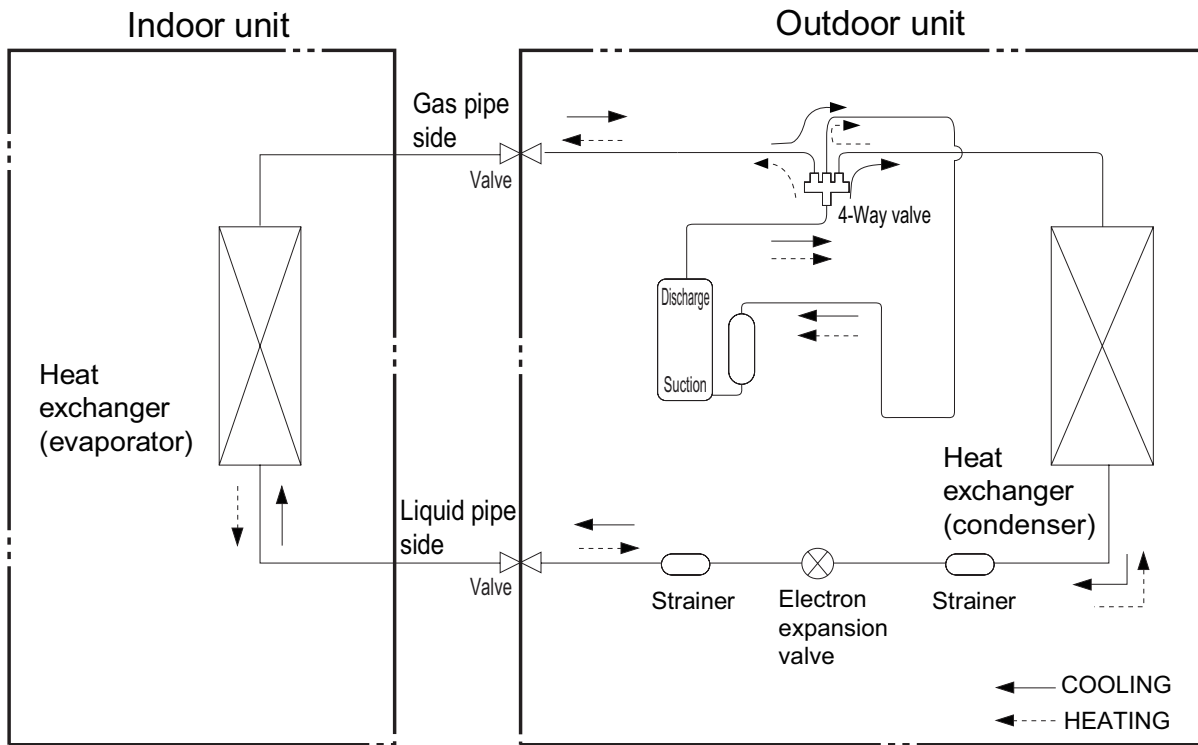

Connection pipe specification:  
Liquid pipe: 1/4"  
Gas pipe: 3/8" 25/35  
Gas pipe: 1/2" 50

# 5. Electrical Part

## 5.1 Wiring Diagram

### • Instruction

Symbol	Symbol Color	Symbol	Symbol Color	Symbol	Name
YE	Yellow	BN	Brown	COMP	Compressor
RD	Red	BU	Blue		Grounding wire
YEGN	Yellow/Green	BK	Black	/	/

Note: Jumper cap is used to determine fan speed and the swing angle of horizontal lover for this model.

### • Indoor Unit

AZI-FO25VE/I

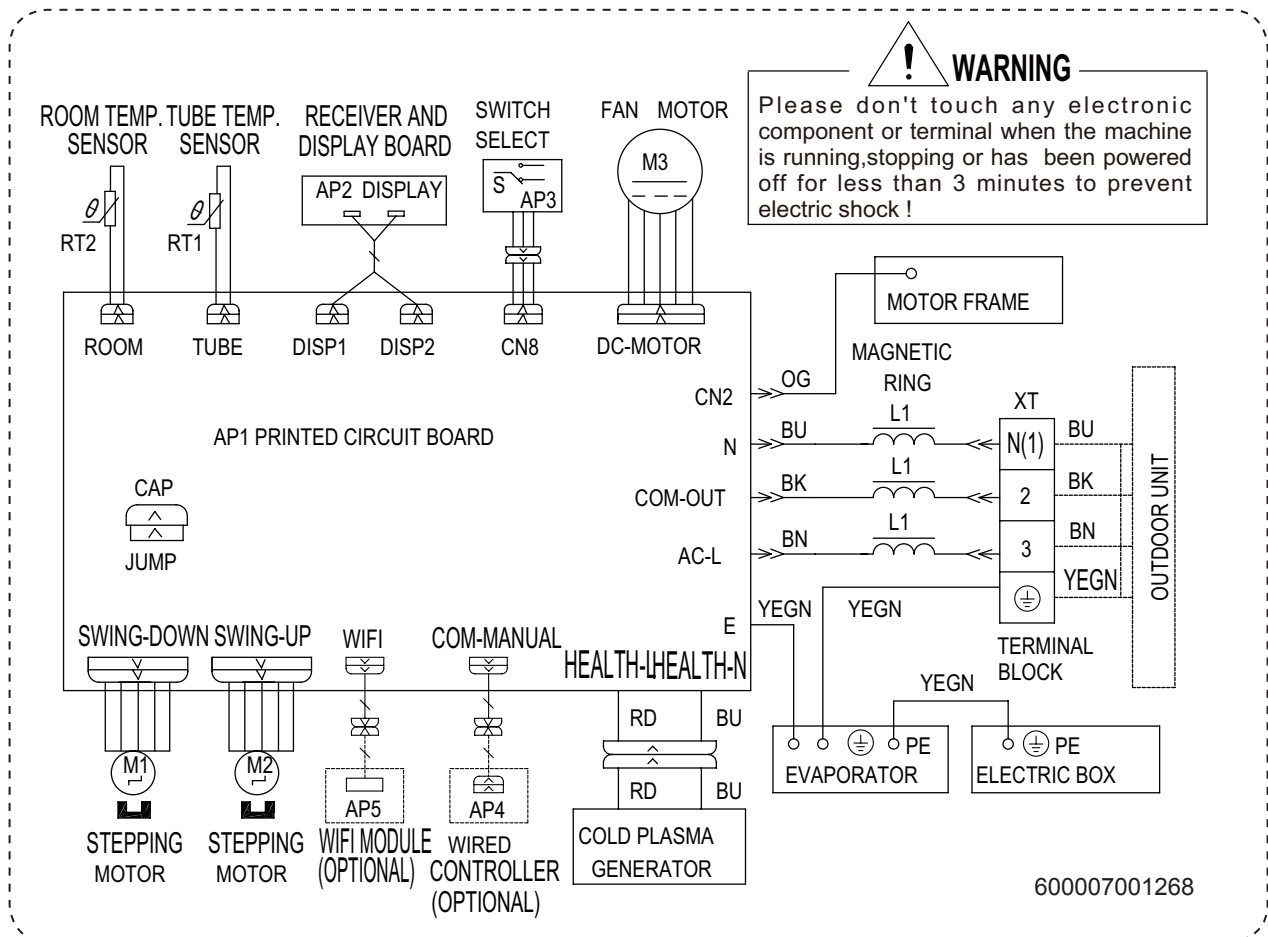

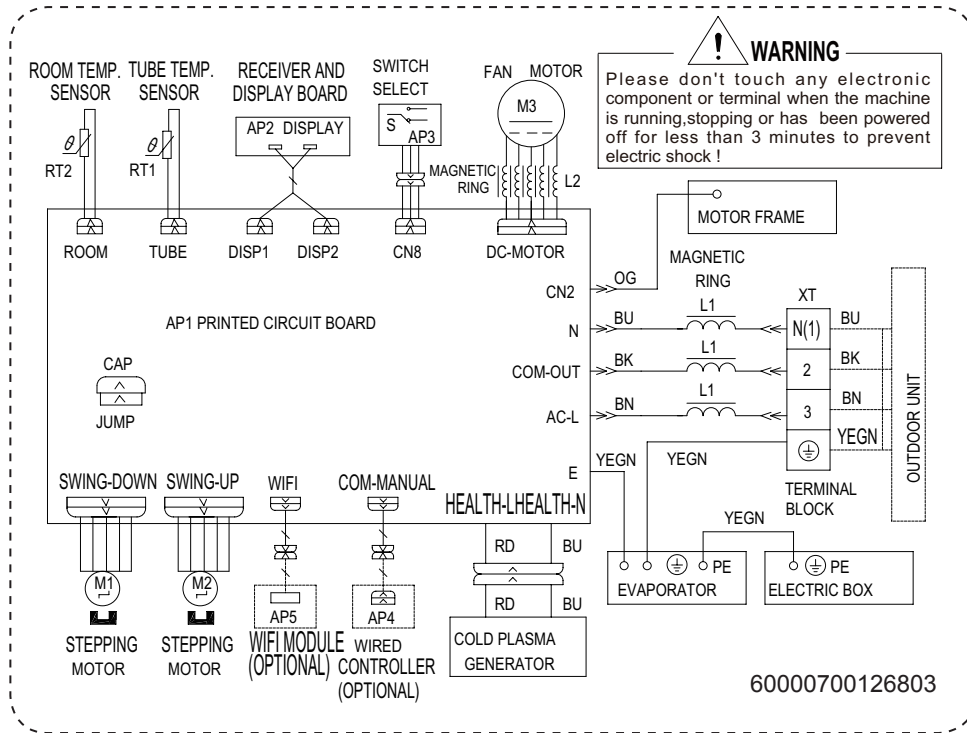

• Outdoor Unit

AZI-FO25VE/O  
AZI-FO35VE/O

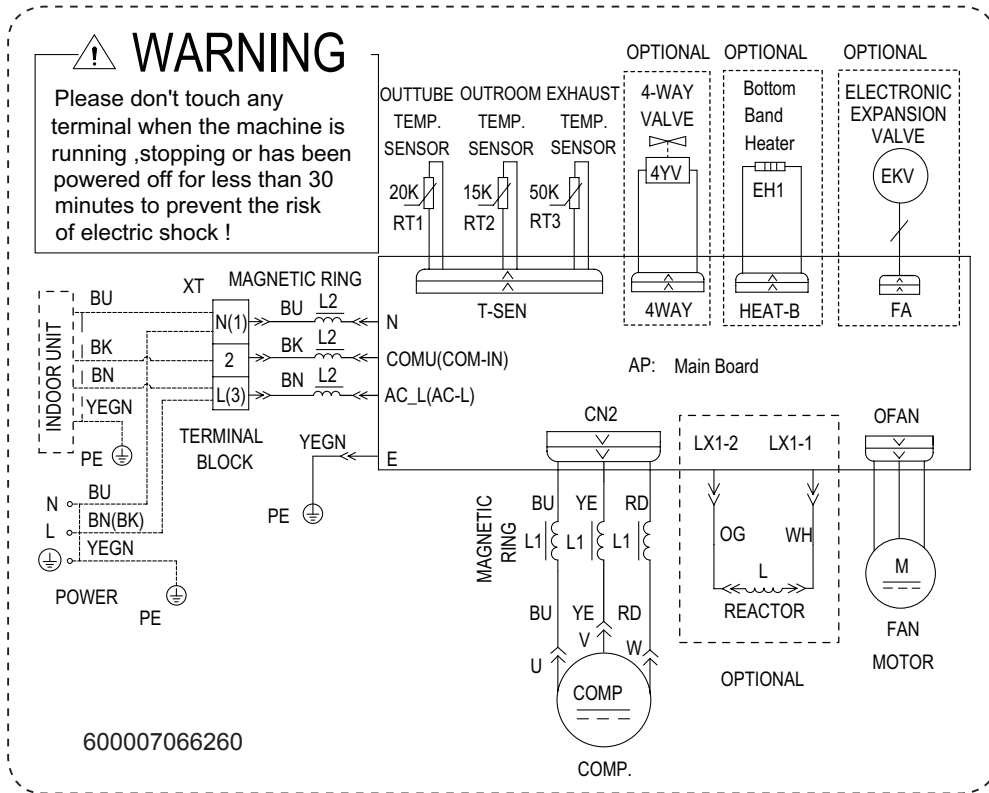

AZI-FO50VE/O

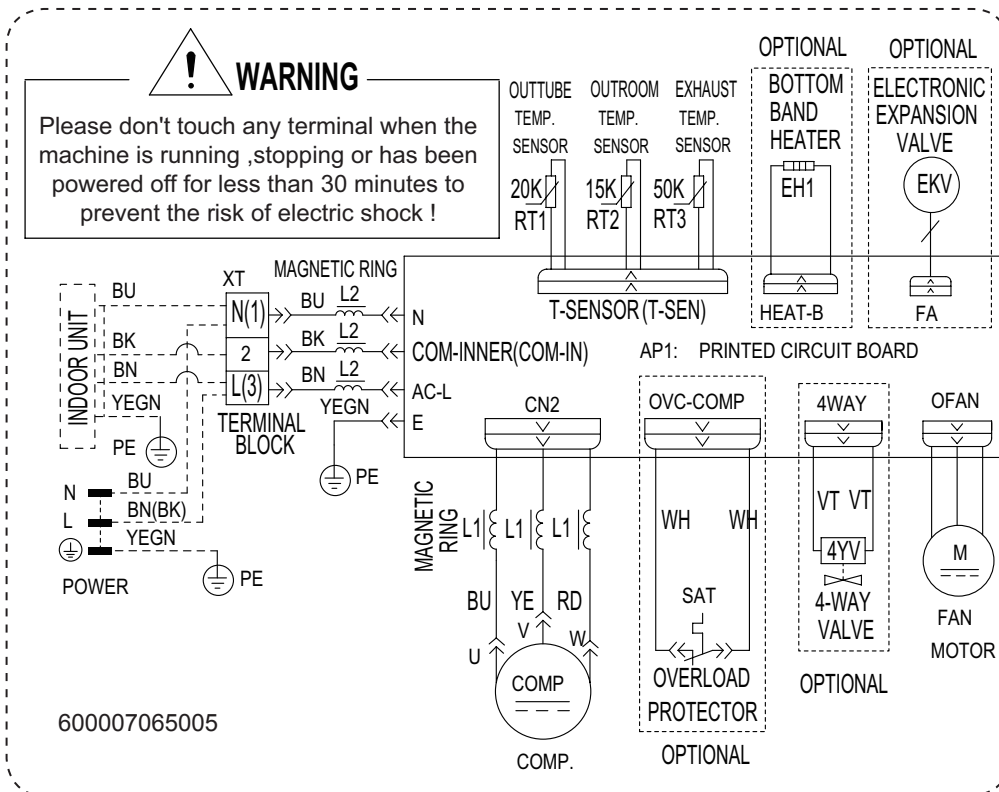

These wiring diagrams are subject to change without notice; please refer to the one supplied with the unit.



## 5.2 PCB Printed Diagram

### • Indoor Unit

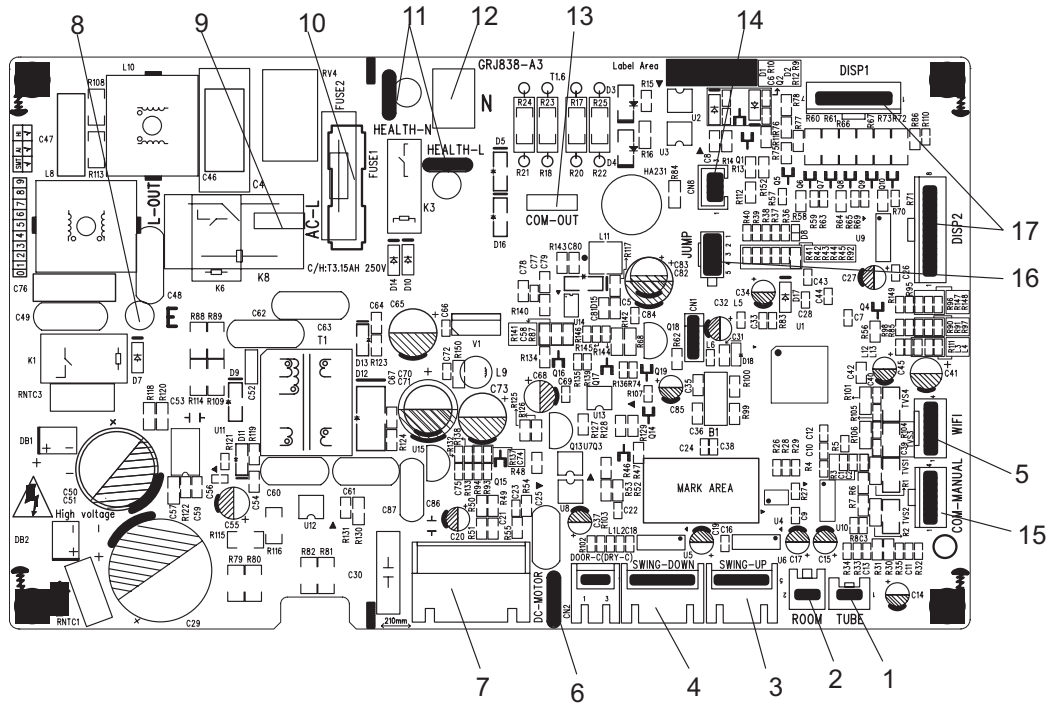

No.	Name	No.	Name
1	Interface of tube temperature sensor	10	Fuse
2	Interface of ambient temperature sensor	11	Terminal for health function (only for the mode with this function)
3	Up swing interface	12	Terminal of neutral wire
4	Down swing interface	13	Communication interface between indoor unit and outdoor unit
5	WIFI interface	14	Control interface of Down swing
6	Interface of EMC shielding wire	15	Wired controlled interface
7	DC motor interface	16	Needle stand of jumper cap
8	Earthing wire of main board	17	Interface of display board
9	Terminal of live wire		

## ● Outdoor Unit

AZI-FO25VE/O  
AZI-FO35VE/O

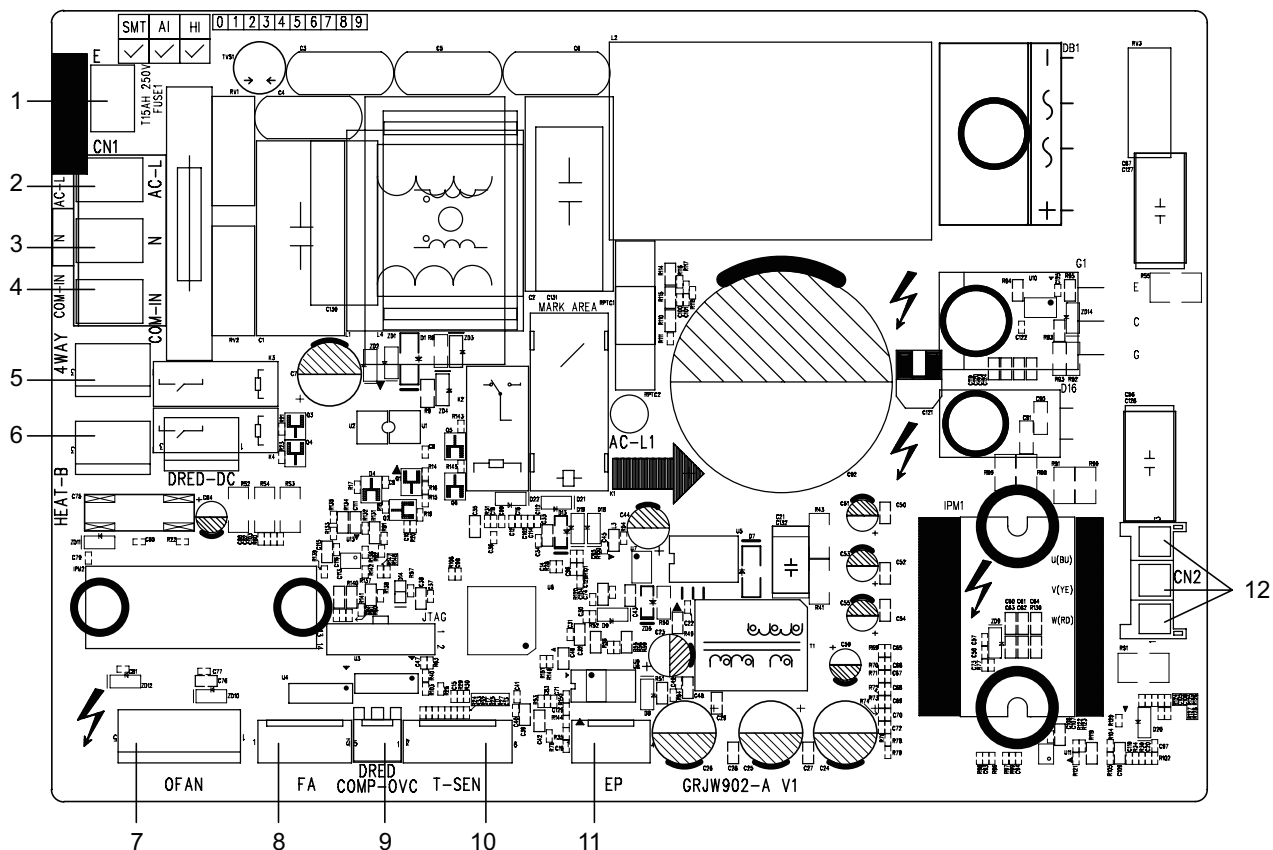

No.	Name
1	Earthing wire terminal
2	Live wire terminal
3	Neutral wire terminal
4	Communication terminal
5	4-way valve terminal
6	Electric heating terminal of chassis

No.	Name
7	Fan motor terminal
8	Electron expansion valve terminal
9	Compressor overload terminal
10	Temperature sensor terminal
11	E store terminal
12	Compressor terminal

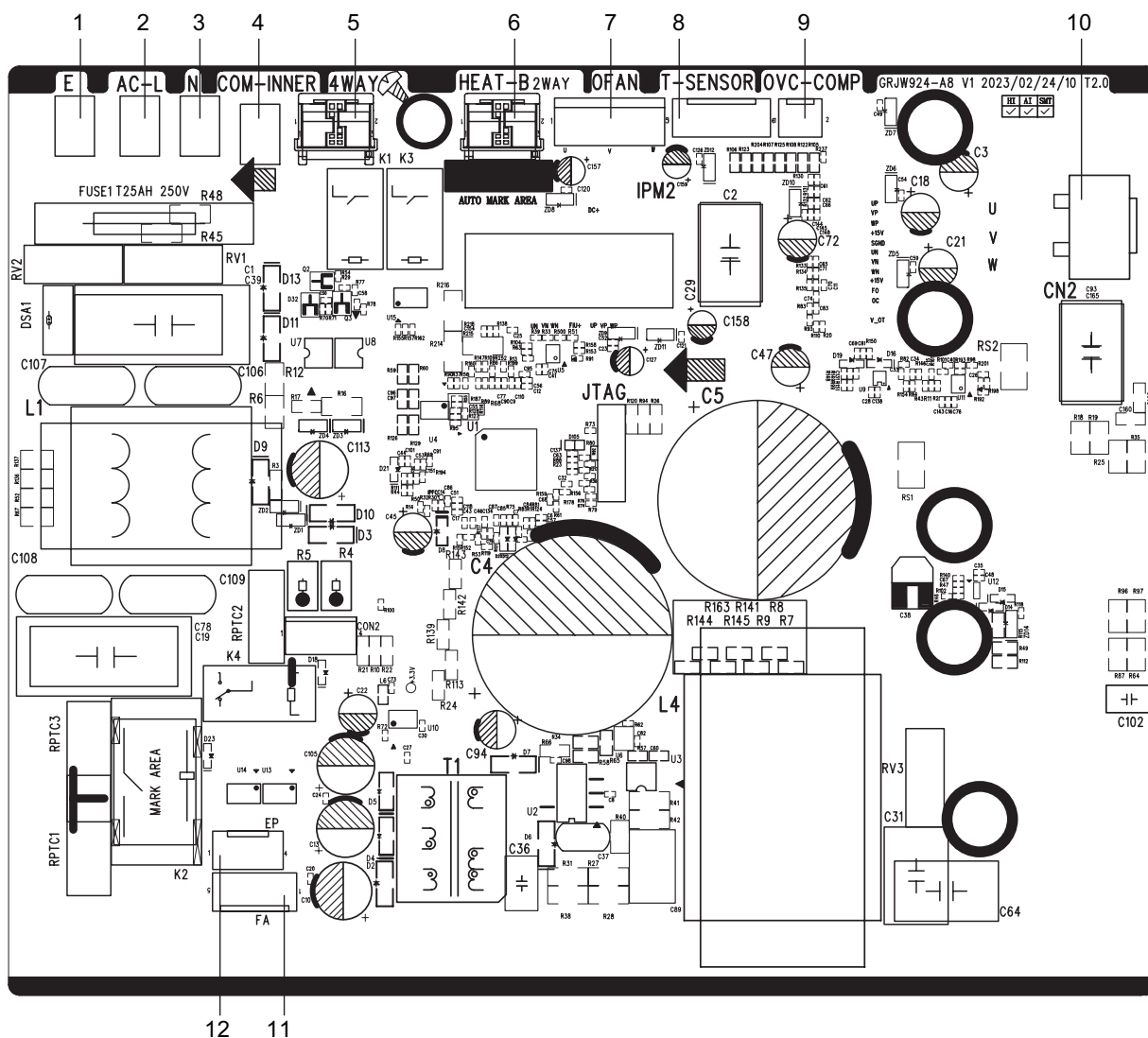

No.	Name	No.	Name
1	Earthing Wire Insertion	7	Outdoor Fan Needle Stand
2	Live Wire Insertion	8	Temperature Sensor Needle Stand
3	Neutral Wire Insertion	9	Compressor Overload Needle Stand
4	Communication Wire Insertion	10	Compressor Needle Stand
5	Four-way Valve Needle Stand	11	Electronic Expansion Valve Needle Stand
6	Chassis Electric Heating Belt Needle Stand	12	EEP Flash Drive Needle Stand

# 6. Function and Control

## 6.1 Remote Controller Introduction

### Buttons on remote controller



- 1 **ON/OFF**  
Press it to start or stop operation.
- 2 **-** : Press it to decrease temperature setting.
- 3 **+** : Press it to increase temperature setting.
- 4 **MODE**  
Press it to select operation mode (AUTO/COOL/DRY/FAN/HEAT).
- 5 **FAN**  
Press it to set fan speed.
- 6 **SWING**  
Press it to set swing angle.
- 7 **I FEEL**
- 8    
Press it to set HEALTH or AIR function.
- 9 **SLEEP**
- 10 **TEMP**
- 11 **QUIET**  
Press it to set QUIET function.
- 12 **CLOCK**  
Press it to set clock.
- 13 **T-ON/T-OFF**  
Press it to set auto-off/auto-on timer.
- 14 **TURBO**
- 15 **LIGHT**  
Press it to turn on/off the light.
- 16 **WiFi**

## Introduction for buttons on remote controller

### Note:

This is a general use remote controller, it could be used for the air conditioners with multifunction; For some function, which the model doesn't have, if press the corresponding button on the remote controller that the unit will keep the original running status.

### 1. ON/OFF button

Press this button to turn on the unit .Press this button again to turn off the unit.

### 2. - button

Press this button to decrease set temperature. Holding it down above 2 seconds rapidly decreases set temperature. In AUTO mode, set temperature is not adjustable.

### 3.+ button

Press this button to increase set temperature.Holding it down above 2 seconds rapidly increases set temperature. In AUTO mode, set temperature is not adjustable.

### 4.MODE:

Each time you press this button,a mode is selected in a sequence that goes from AUTO, COOL,DRY,FAN,and HEAT \*, as the following:



\*Note:Only for models with heating function.

After energization, AUTO mode is defaulted. In AUTO mode, the set temperature will not be displayed on the LED of the indoor, and the unit will automatically select the suitable operation mode in accordance with the room temperature to make indoor room comfortable.

### 5.FAN :

This button is used for setting Fan Speed in the sequence that goes from AUTO, , , to , then back to Auto.

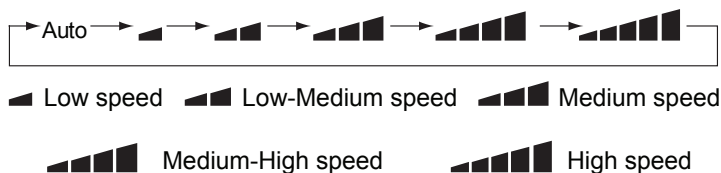

- X-FAN function:Hold fan speed button for 2s in COOL or DRY mode, the icon “ ” is displayed and the indoor fan will continue operation for a few minutes in order to dry the indoor unit even though you have turned off the unit. After energization, X-FAN OFF is defaulted. X-FAN is not available in AUTO, FAN or HEAT mode.

This function indicates that moisture on evaporator of indoor unit will be blown after the unit is stopped to avoid mould.

- Having set X-FAN function on: After turning off the unit by pressing ON/OFF button indoor fan will continue running for a few

minutes. at low speed. In this period, Hold fan speed button for 2s to stop indoor fan directly.

- Having set X-FAN function off: After turning off the unit by pressing ON/OFF button, the complete unit will be off directly.

### 6.SWING:

Press this button to set up &down swing angle, which circularly changes as below:



This remote controller is universal . If any command or is sent out, the unit will carry out the command as or indicates the guide louver swings as:



### 7.I FEEL:

Press this button to turn on I FEEL function. The unit automatically adjust temperature according to the sensed temperature. Press this button again to cancel I FEEL function.

When I FEEL function is turned on, the remote controller should be put within the area where indoor unit can receive the signal sent by the remote controller.

### 8. /

Press this button to achieve the on and off of health and scavenging functions in operation status.

Press this button for the first time to start scavenging function;

LCD displays“”. Press the button for the second time to start health and scavenging functions simultaneously; LCD displays“

” and “”. Press this button for the third time to quit health and scavenging functions simultaneously. Press the button for the fourth time to start health function; LCD display “”. Press this button again to repeat the operation above.

NOTE: This function is applicable to partial of models.

### 9.SLEEP:

Press this button, can select Sleep 1 ( ), Sleep 2 ( ),Sleep 3 ( ) and cancel the Sleep,circulate between these, after electrified, Sleep Cancel is defaulted.

Sleep 1 is Sleep mode 1, in Cool mode: sleep status after run for one hour, the main unit setting temperature will increase 1°C,setting temperature increased 2°C, the unit will run at this setting temperature; In Heat mode: sleep status after run for one hour, the setting temperature will decrease 1°C, 2 hours, setting temperature will decrease 2 °C, then the unit will run at this setting temperature.

Sleep 2 is sleep mode 2, that is air conditioner will run according to the presetting a group of sleep temperature curve.Sleep 3- the

sleep curve setting under Sleep mode by DIY:

(1) Under Sleep 3 mode, press "Turbo" button for a long time, remote control enters into user individuation sleep setting status, at this time, the time of remote control will display "1 hour ", the setting temperature "88" will display the corresponding temperature of last setting sleep curve and blink (The first entering will display according to the initial curve setting value of original factory);

(2) Adjust "+" and "-" button, could change the corresponding setting temperature, after adjusted, press "Turbo "button for confirmation;

(3) At this time, 1 hour will be automatically increased at the timer position on the remote control, (that are "2 hours " or "3 hours " or "8 hours "), the place of setting temperature "88" will display the corresponding temperature of last setting sleep curve and blink;

(4) Repeat the above step (2) ~ (3) operation, until 8 hours temperature setting finished, sleep curve setting finished, at this time, the remote control will resume the original timer display;temperature display will resume to original setting temperature.

Sleep3- the sleep curve setting under SLEEP mode by DIY could be inquired:

The user could accord to sleep curve setting method to inquire the presetting sleep curve, enter into user individuation sleep setting status, but do not change the temperature, press "Turbo" button directly for confirmation.





Note: In the above presetting or enquiry procedure, if continuously within10s, there is no button pressed, the sleep curve setting within10s, there is no button pressed, the sleep curve setting status will be automatically quit and resume to display the original displaying. In the presetting or enquiry procedure, press "ON/OFF" button, "Mode" button, "Timer"button or "Sleep" button, the sleep curve setting or enquiry status will quit similarly.

#### 10.TEMP:

Press this button, could select displaying the indoor setting temperature or indoor ambient temperature.When the indoor unit firstly power on it will display the setting temperature,

if the temperature's displaying status is changed from other status to "",displays the ambient temperature, 5s later or within 5s, it receives other remote control signal that will return to display the setting temperature. if the users haven't set up the temperature displaying status,that will display the setting temperature.

#### 11.QUIET:

Press this button, the Quiet status is under the Auto Quiet mode (display " " and "Auto" signal) and Quiet mode (display " " signal) and Quiet OFF (there is no signal of " " displayed), after powered on, the Quiet OFF is defaulted. Note: Under the Quiet mode (Display " " signal), the fan speed is not available.

#### 12.CLOCK :

Press CLOCK button, blinking  . Within 5 seconds,pressing + or - button adjusts the present time.

Holding down either button above 2 seconds increases or decreases the time by 1 minute every 0.5 second and then by 10 minutes every 0.5 second. During blinking after setting, press CLOCK button again to confirm the setting,and then  will be constantly displayed.

#### 13. T-ON / T-OFF:

Press T-ON button to initiate the auto-ON timer. To cancel the auto-timer program, simply press this button again.



After press of this button,  disappears and "ON "blink s .00:00 is displayed for ON time setting.Within 5 seconds,press + or - butt on to adjust the time value.Every press of either button changes the time setting by 1minute. Holding down either button rapidly changes the time setting by 1 minute and then 10 minutes.Within 5 Seconds after setting,press TIMER ON button to confirm.

Press T-OFF button to initiate the auto-off timer. To cancel the auto-timer program, simply press the button again.TIMER OFF setting is the same as TIMER ON.

#### 14.TURBO:

Press this button to activate / deactivate the Turbo function which enables the unit to reach the preset temperature in the shortest time. In COOL mode, the unit will blow strong cooling air at super high fan speed. In HEAT mode, the unit will blow strong heating air at super high fan speed.

#### 15.LIGHT:

Press LIGHT button to turn on the display's light and press this button again to turn off the display 's light. If the light is turned on ,  is displayed. If the light is turned off,  disappears.

#### 16.WiFi:



Press " WiFi " button to turn on WiFi function, " WiFi " icon will be displayed on the remote controller;

Hold " WiFi " button for 5s to turn off WiFi function and " WiFi " icon will disappear.(This function is only available for some models.)

Under off status, press " MODE " and " WiFi " buttons simultaneously for 1s, WiFi module will restore factory settings.

- This function is only available for some models.

#### 17.Combination of "+" and "-" buttons: About lock

Press " + " and "-" buttons simultaneously to lock or unlock the keypad. If the remote controller is locked,  is displayed. In this case, pressing any button,  blinks three times.

#### 18.Combination of "MODE " and "-" buttons : About switch between Fahrenheit and centigrade

At unit OFF, press "MODE"and " - " buttons simultaneously to switch between °C and °F .

#### 19. Combination of " TEMP " and "CLOCK" buttons : About Energy-saving Function

Press "TEMP" and "CLOCK" simultaneously in COOL mode to start energy-saving function.

Nixie tube on the remote controller displays "SE". Repeat the operation to quit the function.

### 20. Combination of "TEMP" and "CLOCK" buttons : About 8°C Heating Function

Press "TEMP" and "CLOCK" simultaneously in HEAT mode to start 8°C Heating Function

Nixie tube on the remote controller displays "Ⓢ" and a selected temperature of "8°C".

(46°F if Fahrenheit is adopted). Repeat the operation to quit the function.

### 21. About Back-lighting Function

The unit lights for 4s when energizing for the first time, and 3s for later press.

### Replacement of Batteries

1. Remove the battery cover plate from the rear of the remote controller. (As shown in the figure)

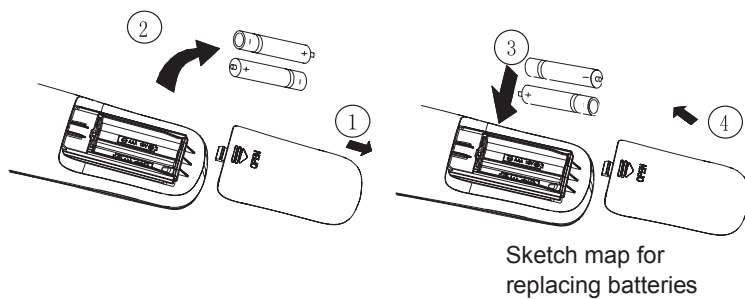

2. Take out the old batteries.

3. Insert two new AAA1.5V dry batteries, and pay attention to the polarity.

4. Reinstall the battery cover plate.

### ★ Notes:

- When replacing the batteries, do not use old or different types of batteries,
- If the remote controller will not be used for a long time, please otherwise, it may cause malfunction. remove batteries to prevent batteries from leaking.
- The operation should be performed in its receiving range.
- It should be kept 1m away from the TV set or stereo sound sets.
- If the remote controller does not operate normally, please take the batteries out and reinsert them after 30 seconds. If it still can't operate properly, replace the batteries.

## 6.2 Brief Description of Modes and Functions

### 1. Cooling mode

(1) Under this mode, the fan and the up swing will operate at setting status. The temperature setting range is 16~30°C.

(2) The unit is stopped because of malfunction of outdoor unit or protection. The indoor unit keeps original operation status and the error code is displayed.

(3) Indoor unit is stopped due to mode shock.

### 2. Drying mode

(1) Under this mode, the fan operates at low speed and the swing operates at setting status. The temperature setting range is 16~30°C.

(2) The unit is stopped because of malfunction of outdoor unit or protection. The indoor unit keeps original operation status and the error code is displayed.

### 3. Heating mode

(1) Under this mode, the temperature setting range is 16~30°C.

(2) Working condition and process for heating

When the unit is turned on under heating mode, the indoor unit turns to cold air prevention status. When the unit is turned off and the

indoor unit has been started up before, the indoor unit blows the residual heat.

(3) Protection function: When the compressor is stopped due to malfunction under heating mode, the indoor unit blows the residual heat.

(4) Blow residual heat

When the unit stops operation as it reaches the temperature point, indoor unit will continue to run for 60s. The fan speed can't be switched during blowing residual heat period. The upper horizontal louver will turn to the defaulted position in cooling. When the unit operates under heating mode or auto heating mode, compressor will be turned on and the corresponding electric expansion valve is

more than 65 and the unit stops operation during the operation status of indoor unit. The upper horizontal louver will turn to the defaulted position in heating mode. The indoor unit operates at low speed for 10s and then the unit stops operation.

(5) Defrosting, oil-returning

As it received the signal of defrosting and oil-returning from outdoor unit, the upper horizontal louver will turn to the minimum angle in

cooling. 10s later, the indoor fan stop operation. During defrosting and oil-returning process and they are quitted within 5mins, all malfunctions for indoor tube temperature sensor won't be detected.

### 4. Working process for AUTO mode (Mode judgment will be performed every 30s)

Under AUTO mode, standard cooling  $T_{\text{preset}}=25^{\circ}\text{C}$  (77°F), standard heating  $T_{\text{preset}}=20^{\circ}\text{C}$  (68°F), and standard fan  $T_{\text{preset}}=25^{\circ}\text{C}$

(77°F).

(1) When  $T_{\text{amb}} \geq 26^{\circ}\text{C}$  (79°F), the unit operation in cooling mode;

(2) Heating pump unit: When  $T_{\text{amb}} \leq 19^{\circ}\text{C}$  (66°F), the unit operates in heating mode;

(3) Cooling only unit:  $T_{\text{amb}} \leq 19^{\circ}\text{C}$  (66°F), the unit operates in fan mode;

(4) When  $19^{\circ}\text{C} < T_{\text{indoor amb}} < 26^{\circ}\text{C}$ , if it turns to auto mode as the unit is turned on for the first time the unit will operate at auto fan mode. If it switch to auto mode from other modes, the unit will

keep previous operation mode (when it turns to dry mode, the unit operates at auto fan mode).

(5) Protection function

Protection function is the same as that in cooling or heating mode.

### 5. Fan mode

Under fan mode, only indoor fan and swing operates. When it operates at auto fan speed, it will operate according to auto fan speed

condition in cooling.

### 6. Mode shock

If the mode shock is 1 which is received by indoor unit from outdoor unit, the loads of indoor unit (indoor unit, auxiliary heating, swing)

stop operation and the error code is displayed. The mode sent to outdoor unit is still remote control receiving mode. The unit will be turned off during mode shock.

If timer ON is reached, and the mode shock is 1 which is received by indoor unit from outdoor unit, the loads of indoor unit (indoor unit, auxiliary heating, swing) stop operation and the error code is displayed. The mode sent to outdoor unit is still remote control receiving mode.

### 7. Other control

#### 7.1 Buzzer

Upon energization or available operating the unit or remote controller, the buzzer will give out a beep.

#### 7.2 Auto button

If this button is pressed, the unit will operate in AUTO mode and indoor fan will operate at auto speed; meanwhile, the swing motor operates. Press this button again to turn off the unit.

#### 7.3 8 °C heating function

Under heating mode, press TEMP+CLOCK buttons simultaneously. Under this mode, "cold air prevention protection" will be shielded.

#### 7.4 I FEEL function

When I FEEL command is received, the controller will operate according to the ambient temperature sent by the remote controller (For defrosting and cold blow prevention, the unit operates according to the ambient temperature sensed by the air conditioner). The remote controller will send ambient temperature data to the controller every 10min. When the data has not been received after 11mins, the unit will operate according to the temperature sensed by the air conditioner. If I FEEL function is not selected, the ambient temperature will be that sensed by the air conditioner. I FEEL function will not be memorized.

#### 7.5 Timer function

General timer and clock timer functions are compatible by equipping remote controller with different functions.

(1) General Timer

Timer ON can be set at unit OFF. If selected ON time is reached, the unit will start to operate according to previous setting status. Time setting range is 0.5-24hr in 30-minute increments.

Timer OFF can be set at unit ON. If selected OFF time is reached, the unit will stop operation. Time setting range is 0.5-24hr in 30-minute increments.

(2) Clock Timer

Timer ON



If timer ON is set during operation of the unit, the unit will continue to operate. If timer ON is set at unit OFF, upon ON time reaches the unit will start to operate according to previous setting status.

#### Timer OFF

If timer OFF is set at unit OFF, the system will keep standby status. If timer OFF is set at unit ON, upon OFF time reaches the unit will stop operation.

#### Timer Change

Although timer has been set, the unit still can be turned on/off by pressing ON/OFF button of remote controller. You can also set the timer once again, and then the unit will operate according to the last setting. If timer ON and timer OFF are set at the same time during operation of the unit, the unit will keep operating at current status till OFF time reaches. If timer ON and timer OFF are set at the same time at unit OFF, the unit will keep stop till ON time reaches. In the future's every day, the system will operate according to presetting mode till OFF.

### 7.6 Sleep function

This mode is only valid in cooling and heating modes. The unit will select proper sleep curve to operate according to different set temperature.

### 7.7 Compulsory defrosting function

When the unit is turned on in heating by remote controller and the set temperature is 16°C, press “+,-,+,-,+,-” continuously within 5s, the indoor unit turns to compulsory defrosting setting and it will send compulsory defrosting mode to outdoor unit.

When indoor unit received the compulsory defrosting signal from outdoor unit, the indoor unit will quit from the compulsory defrosting setting and it will cancel to send compulsory defrosting mode to outdoor unit.

### 7.8 Refrigerant recovery function

Turn to Freon recovery mode: After the unit is energized for 5min, and the unit is turned on at 16°C under cooling mode, press light button on remote controller for 3 times successively within 3s to turn to Freon recovery mode. Fo is displayed and it will send Freon recovery mode to outdoor unit.

Quit from Freon recovery mode: After it turns to Freon mode, if it receives any signal from remote controller or it turns to Freon recovery mode for 25 mins, it will quit from Freon recovery mode.

Turn to the action for Freon recovery mode: indoor unit will be turned on in cooling mode. The fan speed is super-high fan speed and

the set temperature is 16°C. The horizontal louver will turn to the minimum operation angle.

Quit the action for Freon recovery mode: The indoor fan operates at the previous set status by remote controller.

### 7.9 Pilot run function

When the set temperature is 30°C under cooling mode, press “+,-,+,-,+,-” continuously within 5s, the indoor unit turns to pilot run setting mode and it will send pilot run mode to outdoor unit.

Pilot run mode: it operates under cooling mode and “dd” is displayed.

Quit the pilot run mode and indoor unit cancels “dd” display. If it receives “wrong wire connection of malfunction of expansion valve” from outdoor unit, “dn” will be displayed.

## 6.3 GREE+ App Operation Manual

### Control Flow Chart

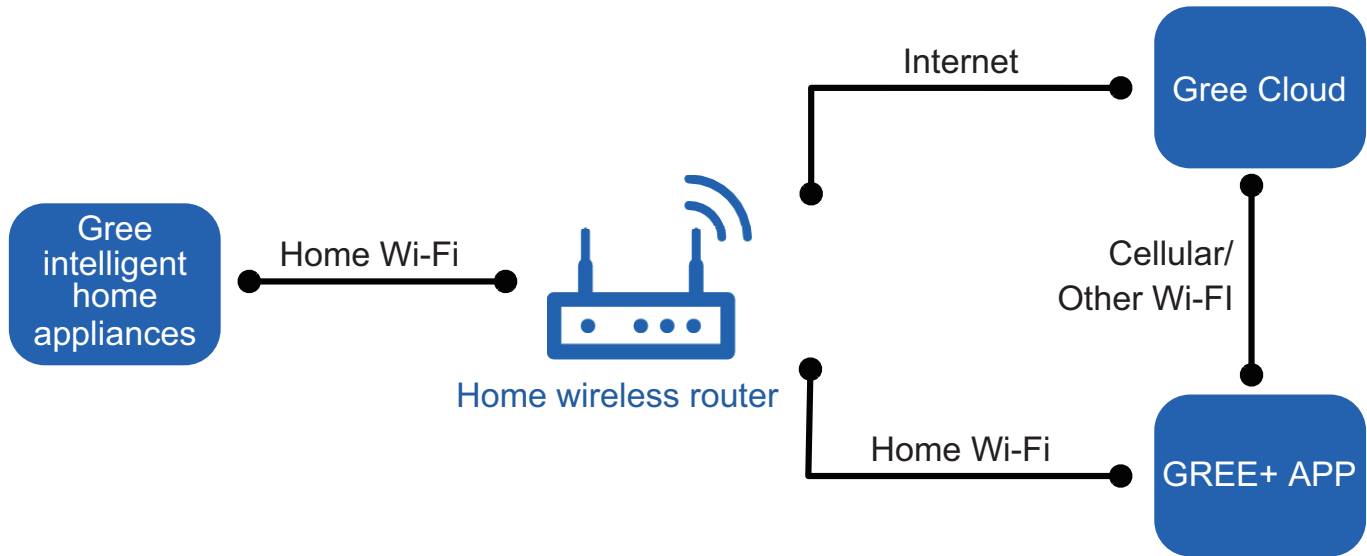

### Operating Systems

Requirement for User's smart phone:



iOS system  
Support iOS7.0 and  
above version



Android system  
Support Android 4.4 and  
above version

### Download and installation



GREE+ App Download Linkage

Scan the QR code or search "GREE+" in the application market to download and install it. When "GREE+" App is installed, register the account and add the device to achieve long-distance control and LAN control of Gree smart home appliances. For more information, please refer to "Help" in App.

## 6.4 Ewpe Smart App Operation Manual

### Control Flow Chart

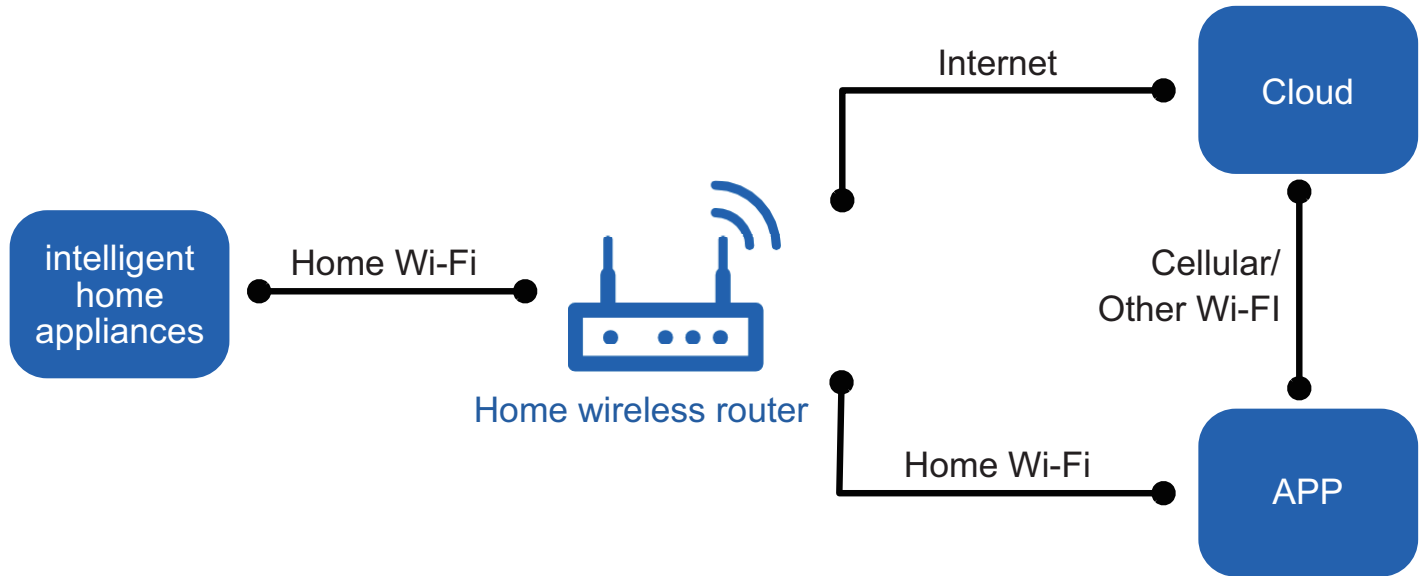

### Operating Systems

Requirement for User's smart phone:



iOS system  
Support iOS7.0 and  
above version



Android system  
Support Android 4.4 and  
above version

### Download and installation



App Download Linkage

Scan the QR code or search "Ewpe Smart" in the application market to download and install it. When "Ewpe Smart" App is installed, register the account and add the device to achieve long-distance control and LAN control of smart home appliances.

For more information, please refer to "Help" in App.

# 7. Notes for Installation and Maintenance

## Safety Precautions: Important!

Please read the safety precautions carefully before installation and maintenance.

The following contents are very important for installation and maintenance.

Please follow the instructions below.

- The installation or maintenance must accord with the instructions.
- Comply with all national electrical codes and local electrical codes.
- Pay attention to the warnings and cautions in this manual.
- All installation and maintenance shall be performed by distributor or qualified person.
- All electric work must be performed by a licensed technician according to local regulations and the instructions given in this manual.
- Be caution during installation and maintenance. Prohibit incorrect operation to prevent electric shock, casualty and other accidents.

## WARNINGS

### Electrical Safety Precautions:

1. Cut off the power supply of air conditioner before checking and maintenance.
2. The air condition must apply specialized circuit and prohibit share the same circuit with other appliances.
3. The air conditioner should be installed in suitable location and ensure the power plug is touchable.
4. Make sure each wiring terminal is connected firmly during installation and maintenance.
5. Have the unit adequately grounded. The grounding wire can't be used for other purposes.
6. Must apply protective accessories such as protective boards, cable-cross loop and wire clip.
7. The live wire, neutral wire and grounding wire of power supply must be corresponding to the live wire, neutral wire and grounding wire of the air conditioner.
8. The power cord and power connection wires can't be pressed by hard objects.
9. If power cord or connection wire is broken, it must be replaced by a qualified person.
10. If the power cord or connection wire is not long enough, please get the specialized power cord or connection wire from the manufacture or distributor. Prohibit prolong the wire by yourself.
11. For the air conditioner without plug, an air switch must

be installed in the circuit. The air switch should be all-pole parting and the contact parting distance should be more than 3mm.

12. Make sure all wires and pipes are connected properly and the valves are opened before energizing.
13. Check if there is electric leakage on the unit body. If yes, please eliminate the electric leakage.
14. Replace the fuse with a new one of the same specification if it is burnt down; Don't replace it with a cooper wire or conducting wire.
15. If the unit is to be installed in a humid place, the circuit breaker must be installed.

### Installation Safety Precautions:

1. Select the installation location according to the requirement of this manual.(See the requirements in installation part)
2. Handle unit transportation with care; the unit should not be carried by only one person if it is more than 20kg.
3. When installing the indoor unit and outdoor unit, a sufficient fixing bolt must be installed; make sure the installation support is firm.
4. Ware safety belt if the height of working is above 2m.
5. Use equipped components or appointed components during installation.
6. Make sure no foreign objects are left in the unit after finishing installation.

### Refrigerant Safety Precautions:

1. When refrigerant leaks or requires discharge during installation, maintenance, or disassembly, it should be handled by certified professionals or otherwise in compliance with local laws and regulations.
- 2.Avoid contact between refrigerant and fire as it generates poisonous gas; Prohibit prolong the connection pipe by welding.
3. Apply specified refrigerant only. Never have it mixed with any other refrigerant. Never have air remain in the refrigerant line as it may lead to rupture or other hazards.
4. Make sure no refrigerant gas is leaking out when installation is completed.
5. If there is refrigerant leakage, please take sufficient measure to minimize the density of refrigerant.
6. Never touch the refrigerant piping or compressor without wearing glove to avoid scald or frostbite.

Improper installation may lead to fire hazard, explosion, electric shock or injury.

# Safety Precautions for Installing and Relocating the Unit:

To ensure safety, please be mindful of the following precautions.

## WARNINGS

**1. When installing or relocating the unit, be sure to keep the refrigerant circuit free from air or substances other than the specified refrigerant.**

Any presence of air or other foreign substance in the refrigerant circuit will cause system pressure rise or compressor rupture, resulting in injury.

**2. When installing or moving this unit, do not charge the refrigerant which is not comply with that on the nameplate or unqualified refrigerant.**

Otherwise, it may cause abnormal operation, wrong action, mechanical malfunction or even series safety accident.

**3. When refrigerant needs to be recovered during relocating or repairing the unit, be sure that the unit is running in cooling mode. Then, fully close the valve at high pressure side (liquid valve). About 30-40 seconds later, fully close the valve at low pressure side (gas valve), immediately stop the unit and disconnect power. Please note that the time for refrigerant recovery should not exceed 1 minute.**

If refrigerant recovery takes too much time, air may be sucked in and cause pressure rise or compressor rupture, resulting in injury.

**4. During refrigerant recovery, make sure that liquid valve and gas valve are fully closed and power is disconnected before detaching the connection pipe.**

If compressor starts running when stop valve is open and connection pipe is not yet connected, air will be sucked in and cause pressure rise or compressor rupture, resulting in injury.

**5. When installing the unit, make sure that connection pipe is securely connected before the compressor starts running.**

If compressor starts running when stop valve is open and connection pipe is not yet connected, air will be sucked in and cause pressure rise or compressor rupture, resulting in injury.

**6. Prohibit installing the unit at the place where there may be leaked corrosive gas or flammable gas.**

If there leaked gas around the unit, it may cause explosion and other accidents.

**7. Do not use extension cords for electrical connections. If the electric wire is not long enough, please contact a local service center authorized and ask for a proper electric wire.**

Poor connections may lead to electric shock or fire.

**8. Use the specified types of wires for electrical connections between the indoor and outdoor units. Firmly clamp the wires so that their terminals receive no external stresses.**

Electric wires with insufficient capacity, wrong wire connections and insecure wire terminals may cause electric shock or fire.

## Safety Precautions for Refrigerant



Appliance filled with flammable gas R32.



Before install and use the appliance, read the owner's manual first.



Before install the appliance, read the installation manual first.



Before repair the appliance, read the service manual first.

- To realize the function of the air conditioner unit, a special refrigerant circulates in the system. The used refrigerant is the fluoride R32, which is specially cleaned. The refrigerant is flammable and inodorous. Furthermore, it can lead to explosion under certain conditions. But the flammability of the refrigerant is very low. It can be ignited only by fire.

- Compared to common refrigerants, R32 is a nonpolluting refrigerant with no harm to the ozone layer. The influence upon the greenhouse effect is also lower. R32 has got very good thermodynamic features which lead to a really high energy efficiency. The units therefore need a less filling.

### WARNING:

- Do not use means to accelerate the defrosting process or to clean, other than those recommended by the manufacturer. Should repair be necessary, contact your nearest authorized Service Centre. Any repairs carried out by unqualified personnel may be dangerous. The appliance shall be stored in a room without continuously operating ignition sources. (for example: open flames, an operating gas appliance or an operating electric heater.)

- Do not pierce or burn.

- Appliance shall be installed, operated and stored in a room with a floor area larger than  $Xm^2$ . (Please refer to table "a" in section of " Safety operation of flammable refrigerant " for space X.)

- Appliance filled with flammable gas R32. For repairs, strictly follow manufacturer's instructions only. Be aware that refrigerants do not contain odour.

- Read specialist's manual.

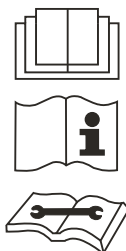

This appliance is not intended for use by persons (including children) with reduced physical, sensory or mental capabilities, or lack of experience and knowledge, unless they have been given supervision

## Safety Operation of Flammable Refrigerant

### Qualification requirement for installation and maintenance man

- All the work men who are engaging in the refrigeration system should bear the valid certification awarded by the authoritative organization and the qualification for dealing with the refrigeration system recognized by this industry. If it needs

other technician to maintain and repair the appliance, they should be supervised by the person who bears the qualification for using the flammable refrigerant.

- It can only be repaired by the method suggested by the equipment's manufacturer.

### Installation notes

- The air conditioner is not allowed to use in a room that has running fire (such as fire source, working coal gas ware, operating heater).

- It is not allowed to drill hole or burn the connection pipe.

- The air conditioner must be installed in a room that is larger than the minimum room area.

The minimum room area is shown on the nameplate or following table a.

- Leak test is a must after installation.

table a - Minimum room area ( m<sup>2</sup> )

Charge amount (kg)	floor location	window mounted	wall mounted	ceiling mounted
≤1.2	/	/	/	/
1.3	14.5	5.2	1.6	1.1
1.4	16.8	6.1	1.9	1.3
1.5	19.3	7	2.1	1.4
1.6	22	7.9	2.4	1.6
1.7	24.8	8.9	2.8	1.8
1.8	27.8	10	3.1	2.1
1.9	31	11.2	3.4	2.3
2	34.3	12.4	3.8	2.6
2.1	37.8	13.6	4.2	2.8
2.2	41.5	15	4.6	3.1
2.3	45.4	16.3	5	3.4
2.4	49.4	17.8	5.5	3.7
2.5	53.6	19.3	6	4

### Maintenance notes

- Check whether the maintenance area or the room area meet the requirement of the nameplate.

— Its only allowed to be operated in the rooms that meet the requirement of the nameplate.

- Check whether the maintenance area is well-ventilated.
  - The continuous ventilation status should be kept during the operation process.
- Check whether there is fire source or potential fire source in the maintenance area.
  - The naked flame is prohibited in the maintenance area; and the “no smoking” warning board should be hanged.
- Check whether the appliance mark is in good condition.
  - Replace the vague or damaged warning mark.

## Welding

- If you should cut or weld the refrigerant system pipes in the process of maintaining, please follow the steps as below:
  - a. Shut down the unit and cut power supply
  - b. Eliminate the refrigerant
  - c. Vacuuming
  - d. Clean it with N<sub>2</sub> gas
  - e. Cutting or welding
  - f. Carry back to the service spot for welding
- Make sure that there isn't any naked flame near the outlet of the vacuum pump and its well-ventilated.
- The refrigerant should be recycled into the specialized storage tank.

## Filling the refrigerant

- Use the refrigerant filling appliances specialized for R32. Make sure that different kinds of refrigerant won't contaminate with each other.
- The refrigerant tank should be kept upright at the time of filling refrigerant.
- Stick the label on the system after filling is finished (or haven't finished).
- Don't overfilling.
- After filling is finished, please do the leakage detection before test running; another time of leak detection should be done when its removed.

## Safety instructions for transportation and storage

- Please use the flammable gas detector to check before unload and open the container.
- No fire source and smoking.
- According to the local rules and laws.

## Specialist's Manual

- The following checks shall be applied to installations using flammable refrigerants:
  - the charge size is in accordance with the room size within which the refrigerant containing parts are installed;
  - the ventilation machinery and outlets are operating adequately and are not obstructed;
  - if an indirect refrigerating circuit is being used, the secondary circuit shall be checked for the presence of refrigerant;
  - marking to the equipment continues to be visible and legible. Markings and signs that are illegible shall be corrected;

– refrigeration pipe or components are installed in a position where they are unlikely to be exposed to any substance which may corrode refrigerant containing components, unless the components are constructed of materials which are inherently resistant to being corroded or are suitably protected against being so corroded.

- Repair and maintenance to electrical components shall include initial safety checks and component inspection procedures. If a fault exists that could compromise safety, then no electrical supply shall be connected to the circuit until it is satisfactorily dealt with. If the fault cannot be corrected immediately but it is necessary to continue operation, an adequate temporary solution shall be used. This shall be reported to the owner of the equipment so all parties are advised.

- Initial safety checks shall include:

- that capacitors are discharged: this shall be done in a safe manner to avoid possibility of sparking;
- that no live electrical components and wiring are exposed while charging, recovering or purging the system;
- that there is continuity of earth bonding.

- Checks to the area

Prior to beginning work on systems containing flammable refrigerants, safety checks are necessary to ensure that the risk of ignition is minimised. For repair to the refrigerating system, DD.4.3 to DD.4.7 shall be completed prior to conducting work on the system.

- Work procedure

Work shall be undertaken under a controlled procedure so as to minimise the risk of a flammable gas or vapour being present while the work is being performed.

- General work area

All maintenance staff and others working in the local area shall be instructed on the nature of work being carried out. Work in confined spaces shall be avoided.

- Checking for presence of refrigerant

The area shall be checked with an appropriate refrigerant detector prior to and during work, to ensure the technician is aware of potentially toxic or flammable atmospheres. Ensure that the leak detection equipment being used is suitable for

use with all applicable refrigerants, i.e. non-sparking, adequately sealed or intrinsically safe.

- Presence of fire extinguisher

If any hot work is to be conducted on the refrigeration equipment or any associated parts, appropriate fire extinguishing equipment shall be available to hand. Have a dry powder or CO<sub>2</sub> fire extinguisher adjacent to the charging area.

- Ventilated area

Ensure that the area is in the open or that it is adequately ventilated before breaking into the system or conducting any hot work. A degree of ventilation shall continue during the period that the work is carried out. The ventilation should safely disperse any released refrigerant and

preferably expel it externally into the atmosphere.

- Checks to the refrigeration equipment

Where electrical components are being changed, they shall be fit for the purpose and to the correct specification. At all times the manufacturer's maintenance and service guidelines shall be followed. If in doubt, consult the manufacturer's technical department for assistance.

- Checks to electrical devices

- that capacitors are discharged: this shall be done in a safe manner to avoid possibility of sparking;

- that no live electrical components and wiring are exposed while charging, recovering or purging the system.

- No ignition sources

No person carrying out work in relation to a refrigerating system which involves exposing any pipe work shall use any sources of ignition in such a manner that it may lead to the risk of fire or explosion. All possible ignition sources, including cigarette smoking, should be kept sufficiently far away from the site of installation, repairing, removing and disposal, during which refrigerant can possibly be released to the surrounding space. Prior to work taking place, the area around the equipment is to be surveyed to make sure that there are no flammable hazards or ignition risks.

"No Smoking" signs shall be displayed.

- Repairs to sealed components

During repairs to sealed components, all electrical supplies shall be disconnected from the equipment being worked upon prior to any removal of sealed covers, etc.

If it is absolutely necessary to have an electrical supply to equipment during servicing, then a permanently operating form of leak detection shall be located at the most critical point to warn of a potentially hazardous situation.

Particular attention shall be paid to the following to ensure that by working on electrical components, the casing is not altered in such a way that the level of protection is affected. This shall include damage to cables, excessive number of connections, terminals not made to original specification, damage to seals, incorrect fitting of glands, etc.

- Ensure that the apparatus is mounted securely.

- Ensure that seals or sealing materials have not degraded to the point that they no longer serve the purpose of preventing the ingress of flammable atmospheres.

Replacement parts shall be in accordance with the manufacturer's specifications.

NOTE: The use of silicon sealant can inhibit the effectiveness of some types of leak detection equipment. Intrinsically safe components do not have to be isolated prior to working on them.

- Repair to intrinsically safe components

Do not apply any permanent inductive or capacitance loads to the circuit without ensuring that this will not exceed the permissible voltage and current permitted for the equipment

in use. Intrinsically safe components are the only types that can be worked on while live in the presence of a flammable atmosphere. The test apparatus shall be at the correct rating. Replace components only with parts specified by the manufacturer. Other parts may result in the ignition of refrigerant in the atmosphere from a leak.

- Cabling

Check that cabling will not be subject to wear, corrosion, excessive pressure, vibration, sharp edges or any other adverse environmental effects. The check shall also take into account the effects of aging or continual vibration from sources such as compressors or fans.

- Leak detection methods

Leak detection fluids are suitable for use with most refrigerants but the use of detergents containing chlorine shall be avoided as the chlorine may react with the refrigerant and corrode the copper pipe-work.

- Detection of flammable refrigerants

Under no circumstances shall potential sources of ignition be used in the searching for or detection of refrigerant leaks. A halide torch (or any other detector using a naked flame) shall not be used.

The following leak detection methods are deemed acceptable for all refrigerant systems.

Electronic leak detectors may be used to detect refrigerant leaks but, in the case of flammable refrigerants, the sensitivity may not be adequate, or may need re-calibration.

(Detection equipment shall be calibrated in a refrigerant-free area.) Ensure that the detector is not a potential source of ignition and is suitable for the refrigerant used. Leak detection equipment shall be set at a percentage of the LFL of the refrigerant and shall be calibrated to the refrigerant employed, and the appropriate percentage of gas (25% maximum) is confirmed.

Leak detection fluids are also suitable for use with most refrigerants but the use of detergents containing chlorine shall be avoided as the chlorine may react with the refrigerant and corrode the copper pipe-work.

NOTE: Examples of leak detection fluids are

- bubble method,

- fluorescent method agents.

If a leak is suspected, all naked flames shall be removed/ extinguished.

If a leakage of refrigerant is found which requires brazing, all of the refrigerant shall be recovered from the system, or isolated (by means of shut off valves) in a part of the system remote from the leak. Removal of refrigerant shall be according to clause DD.9.

- Removal and evacuation

When breaking into the refrigerant circuit to make repairs - or for any other purpose

- conventional procedures shall be used. However, for



flammable refrigerants it is important that best practice is followed since flammability is a consideration. The following procedure shall be adhered to:

- remove refrigerant;
- purge the circuit with inert gas (optional for A2L);
- evacuate (optional for A2L);
- purge with inert gas (optional for A2L);
- open the circuit by cutting or brazing.

The refrigerant charge shall be recovered into the correct recovery cylinders.

For appliances containing flammable refrigerants other than A2L refrigerants, the system shall be purged process may need to be repeated several times. Compressed air or oxygen shall not be used for purging refrigerant systems.

For appliances containing flammable refrigerants, other than A2L refrigerants,

refrigerants purging shall be achieved by breaking the vacuum in the system with oxygen-free nitrogen and continuing to fill until the working pressure is achieved,

then venting to atmosphere, and finally pulling down to a vacuum. This process shall be repeated until no refrigerant is within the system. When the final oxygen-free nitrogen charge is used, the system shall be vented down to atmospheric pressure to enable work to take place. This operation is absolutely vital if brazing operations on the pipe-work are to take place.

Ensure that the outlet for the vacuum pump is not close to any potential ignition sources and that ventilation is available.

#### • Charging procedures

In addition to conventional charging procedures, the following requirements shall be followed.

- Ensure that contamination of different refrigerants does not occur when using charging equipment. Hoses or lines shall be as short as possible to minimise the amount of refrigerant contained in them.

- Cylinders shall be kept in an appropriate position according to the instructions.

- Ensure that the refrigerating system is earthed prior to charging the system with refrigerant.

- Label the system when charging is complete (if not already).

- Extreme care shall be taken not to overfill the refrigerating system. Prior to recharging the system, it shall be pressure-tested with the appropriate purging gas. The system shall be leak-tested on completion of charging but prior to commissioning. A follow up leak test shall be carried out prior to leaving the site.

#### • Decommissioning

Before carrying out this procedure, it is essential that the technician is completely familiar with the equipment and all its detail. It is recommended good practice that all refrigerants are recovered safely. Prior to the task being carried out, an oil and

refrigerant sample shall be taken in case analysis is required prior to re-use of reclaimed refrigerant. It is essential that electrical power is available before the task is commenced.

a) Become familiar with the equipment and its operation.

b) Isolate system electrically.

c) Before attempting the procedure, ensure that:

- mechanical handling equipment is available, if required, for handling refrigerant cylinders;

- all personal protective equipment is available and being used correctly;

- the recovery process is supervised at all times by a competent person;

- recovery equipment and cylinders conform to the appropriate standards.

d) Pump down refrigerant system, if possible.

e) If a vacuum is not possible, make a manifold so that refrigerant can be removed from various parts of the system.

f) Make sure that cylinder is situated on the scales before recovery takes place.

g) Start the recovery machine and operate in accordance with manufacturer's instructions.

h) Do not overfill cylinders. (No more than 80% volume liquid charge).

i) Do not exceed the maximum working pressure of the cylinder, even temporarily.

j) When the cylinders have been filled correctly and the process completed, make sure that the cylinders and the equipment are removed from site promptly and all isolation valves on the equipment are closed off.

k) Recovered refrigerant shall not be charged into another refrigeration system unless it has been cleaned and checked.

#### • Labelling

Equipment shall be labelled stating that it has been decommissioned and emptied of refrigerant. The label shall be dated and signed. For appliances containing flammable refrigerants, ensure that there are labels on the equipment stating the equipment contains flammable refrigerant.

#### • Recovery

When removing refrigerant from a system, either for servicing or decommissioning,

it is recommended good practice that all refrigerants are removed safely.

When transferring refrigerant into cylinders, ensure that only appropriate refrigerant recovery cylinders are employed. Ensure that the correct number of cylinders for holding the total system charge are available. All cylinders to be used are designated for the recovered refrigerant and labelled for that refrigerant (i.e. special cylinders for the recovery of refrigerant). Cylinders shall be complete with pressure-relief valve and associated shut-off valves in good working order. Empty recovery cylinders are evacuated and, if possible, cooled before recovery occurs.

The recovery equipment shall be in good working order with a set of instructions concerning the equipment that is at hand and shall be suitable for the recovery of all appropriate refrigerants including, when applicable, flammable refrigerants. In addition, a set of calibrated weighing scales shall be available and in good working order. Hoses shall be complete with leak-free disconnect couplings and in good condition. Before using the recovery machine, check that it is in satisfactory working order, has been properly maintained and that any associated electrical components are sealed to prevent ignition in the event of a refrigerant release. Consult manufacturer if in doubt.

The recovered refrigerant shall be returned to the refrigerant supplier in the correct recovery cylinder, and the relevant waste transfer note arranged. Do not mix refrigerants in recovery units and especially not in cylinders.

If compressors or compressor oils are to be removed, ensure that they have been evacuated to an acceptable level to make certain that flammable refrigerant does not remain within the lubricant. The evacuation process shall be carried out prior to returning the compressor to the suppliers. Only electric heating to the compressor body shall be employed to accelerate this process. When oil is drained from a system, it shall be carried out safely.

- **General**

That compliance with national gas regulations shall be observed.

That mechanical connections made in accordance with 22.118 shall be accessible for maintenance purposes.

# Main Tools for Installation and Maintenance



Level meter



Measuring tape



Screw driver



Impact drill



Drill head



Electric drill



Electroprobe



Universal meter



Torque wrench



Open-end wrench



Inner hexagon spanner



Electronic leakage detector



Vacuum pump



Pressure meter



Pipe pliers



Pipe pliers



Pipe cutter



Pipe expander



Pipe bender



Soldering appliance



Refrigerant container



Electronic scale

# 8. Installation

## 8.1 Requirements for Electric Connection

### 1. Safety Precaution

- (1) Must follow the electric safety regulations when installing the unit.
- (2) If the supply cord is damaged, it must be replaced by the manufacturer or its service agent or a similarly qualified person in order to (avoid a hazard).
- (3) According to the local safety regulations, use qualified power supply circuit and air switch.
- (4) A air switch having a contact separation of at least 3mm in all poles should be fixed in fixed wiring.
- (5) The appliance shall be installed in accordance with national wiring regulation.
- (6) The air switch must have the functions of magnetic tripping and heat tripping in order to prevent short circuit or overload. Please install the air switch with suitable capacity according to the sheet below.
- (7) Make sure the power supply matches with the requirement of air conditioner. Unstable power supply or incorrect wiring may result in electric shock, fire hazard or malfunction. Please install proper power supply cables before using the air conditioner.
- (8) Properly connect the live wire, neutral wire and grounding wire of power socket.
- (9) Be sure to cut off the power supply before proceeding any work related to electric safety.
- (10) Do not put through the power before finishing installation.

### 2. Grounding Requirement

- (1) The air conditioner is first class electric appliance. It must be properly grounded with specialized grounding device by a professional. Please make sure it is always grounded effectively, otherwise it may cause electric shock.
- (2) The yellow-green wire in air conditioner is grounding wire, which can't be used for other purposes.
- (3) The grounding resistance should comply with national electric safety regulations.

Air-Conditioner	Air Switch Capacity
09/12K	10A
18K	16A

## 8.2 Installation of indoor unit

### 1. Selection of Installation Location

- (1) Such a place where cool air can be distributed throughout the room.
- (2) Such a place where condensation water is easily drained out.
- (3) Such a place that can handle the weight of indoor unit.
- (4) Such a place which has easy access for maintenance.
- (5) The appliance shall not be installed in the laundry.

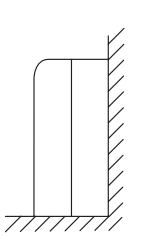
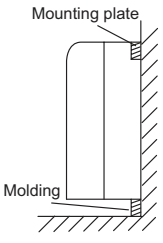
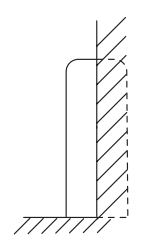
Exposed	Half concealed	Concealed
		
Floor Installation	Wall Installation	Grid(field supply)

### There are 2 styles of installation

- Ceiling type
- Floor type

### Each type is similar to the other as follows:

The indoor unit should be sited in a place where:

- (1) The restrictions on installation specified in the indoor unit installation drawings are met.
- (2) Both air intake and exhaust have clear paths met.
- (3) The unit is not in the path of direct sunlight.
- (4) The unit is away from the source of heat or steam.
- (5) There is no source of machine oil vapour (this may shorten indoor unit life).
- (6) Cool(warm) air is circulated throughout the room.
- (7) The unit is away from electronic ignition type fluorescent lamps (inverter or rapid start type) as they may shorten the remote controller range.
- (8) The unit is at least 1 metre away from any television or radio set(unit may cause interference with the picture or sound).

Location for securing the installation panel.

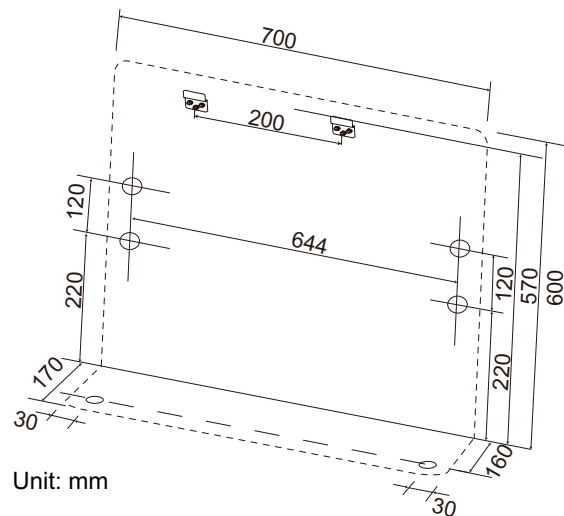

### Cautions for installation where air conditioner troubles liable to occur.

- Where there is too much of oil area.
  - Where it is acid base area.
  - Where there is irregular electrical supply.
- Schematic drawing of hooks:

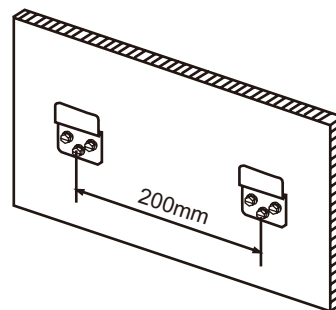

### 2. Indoor Unit Installation Drawings

The indoor unit may be mounted in any of the three styles

shown here.

Console unit shall be installed on the ground or the position where is 0.3m from the floor.

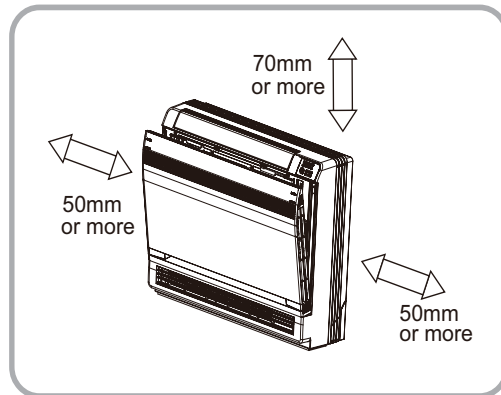
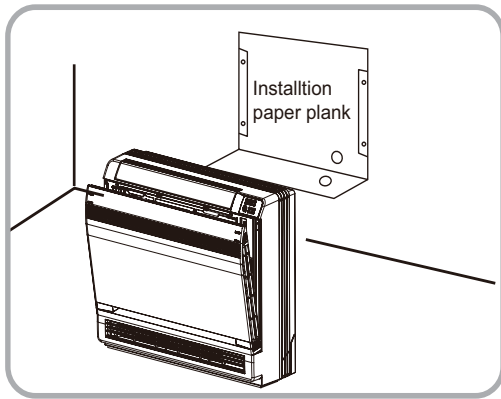

### 3. Refrigerant Piping

- (1) Drill a hole ( 65mm in diameter ) in the spot indicated by  the symbol in the illustration ad below .
- (2) The location of the hole is different depending on which side of the pipe is taken out .
- (3) For piping , see 6. Connecting the refrigerant pipe , under Indoor Unit Installation.
- (4) Allow space around the pipe for a easier indoor unit pipe connection.

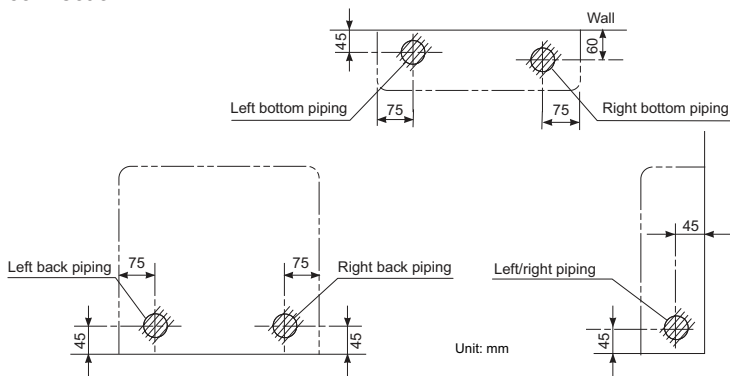

### CAUTION

Min. allowable length

- The suggested shortest pipe length is 2.5m, in order to avoid noise from the outdoor unit and vibration. (Mechanical noise and vibration may occur depending on how the unit is

installed and the environment in which it is used.)

- See the installation manual for the outdoor unit for the maximum pipe length.
- For multi-connections , see the installation manual for the multi-outdoor unit.

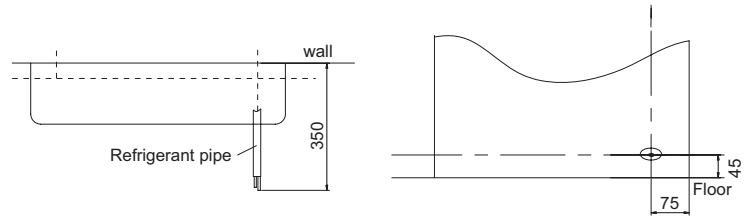

### 4. Boring a Wall Hole and Installing Wall Embedded Pipe

- For walls containing metal frame or metal board , be sure to use a wall embedded pipe and wall cover in the feed-through hole to
  - Be sure to caulk the gaps around the pipes with caulking material to prevent water leakage.
- (1) Bore a feed-through hole of 55mm in the wall so it has a down slope toward the outside.
  - (2) Insert a wall pipe into the hole.
  - (3) Insert a wall cover into wall pipe .
  - (4) After completing refrigerant piping, wiring, and drain piping, caulk pipe hole gap with putty.

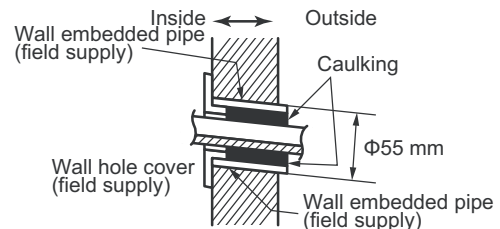

### 5. Drain Piping

- (1) Use commercial rigid polyvinyl chloride pipe general VP 20 pipe, outer diameter 26mm, inner diameter 20mm for the drain pipe.
- (2) The drain hose (outer diameter 18mm at connecting end, 220mm long) is supplied with the indoor unit. Prepare the drain pipe picture below position.
- (3) The drain pipe should be inclined downward so that water will flow smoothly without any accumulation. (Should not be trap.)
- (4) Insert the drain hose to this depth so it won't be pulled out of the drain pipe.
- (5) Insulate the indoor drain pipe with 10mm or more of insulation material to prevent condensation.
- (6) Remove the air filters and pour some water into the drain pan to check the water flows smoothly.

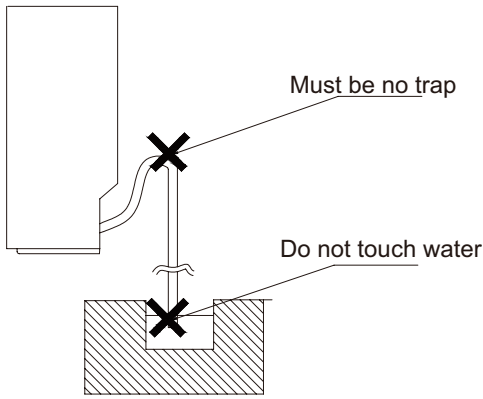
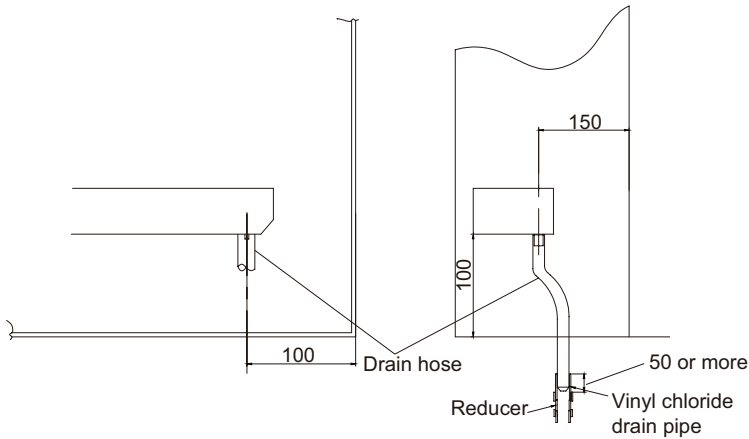

## 6. Installing Indoor Unit Preparation

- Open the front panel, remove the 4 screws and dismount the front grille while pulling it forward.
- Follow the arrows to disengage the clasps on the front case to remove it.
- Follow the procedure below when removing the slit portions.

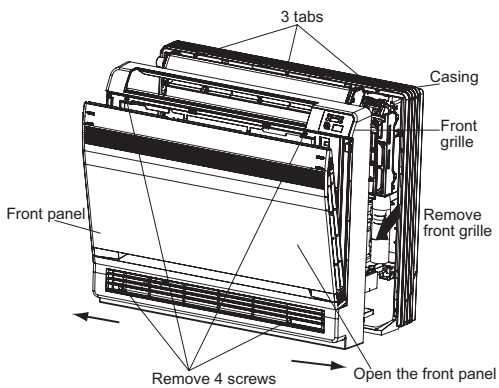

### ■ For Moldings

- Remove the pillars. (Remove the slit portions on the bottom frame using nippers.)

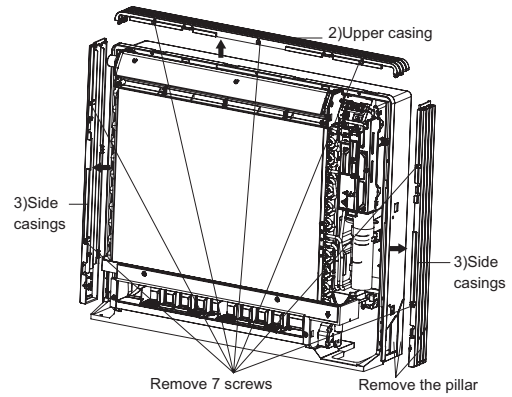

### ■ For Side Piping

- Remove the pillars.
  - (1) Remove the 7 screws.
  - (2) Remove the upper casing (2 tabs).
  - (3) Remove the left and right casings (2 tabs on each side).
  - (4) Remove the slit portions on the bottom frame and casings using nippers.
  - (5) Return by following the steps in reverse order (3>2>1).

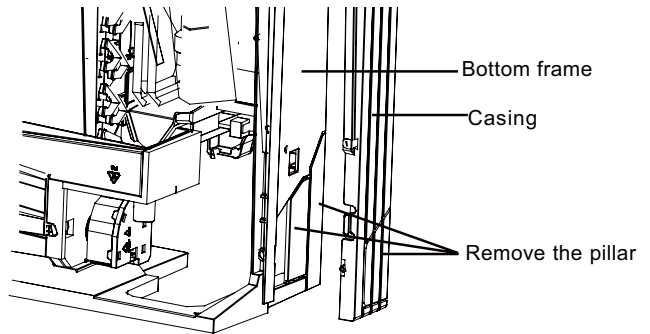
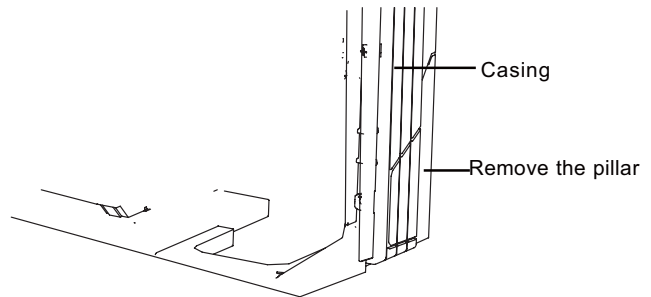

### Installation

- Secure using 6 screws for floor installations. (Do not forget to secure to the rear wall.)
- For wall installations, secure the mounting plate using 5 screws and the indoor unit using 4 screws. The mounting plate should be installed on a wall which can support the weight of the indoor unit.
  - (1) Temporarily secure the mounting plate to the wall, make sure that the panel is completely level, and mark the boring points on the wall.
  - (2) Secure the mounting plate to the wall with screws.

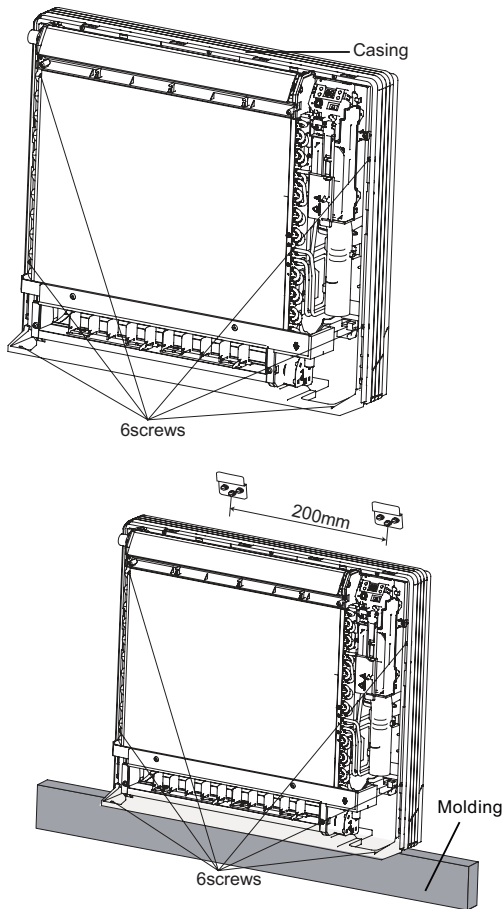

(3) Once refrigerant piping and drain piping connections are complete, fill in the gap of the through hole with putty. A gap can lead to condensation on the refrigerant pipe, and drain pipe, and the entry of insects into the pipes.

(4) Attach the front panel and front grille in their original positions once all connections are complete.

### 7. Flaring the Pipe End

- (1) Cut the pipe end with a pipe cutter.
- (2) Remove burrs with the cut surface facing downward so that the chips do not enter the pipe.
- (3) Fit the flare nut on the pipe.
- (4) Flare the pipe.
- (5) Check that the flaring is properly made.

### ⚠ CAUTION

- (1) **DO not use mineral oil on flared part.**
- (2) **Prevent mineral oil from getting into the system as this would reduce the lifetime of the units.**
- (3) **Never use piping which had been used for previous installations. Only use parts which are delivered with the unit.**
- (4) **Do never install a drier to this R32 unit in order to guarantee its lifetime.**
- (5) **The drying material may dissolve and damage the system.**
- (6) **Incomplete flaring may cause refrigerant gas leakage.**

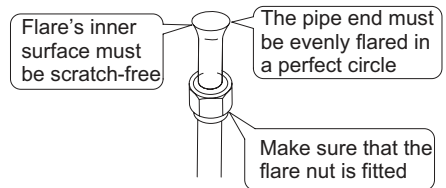
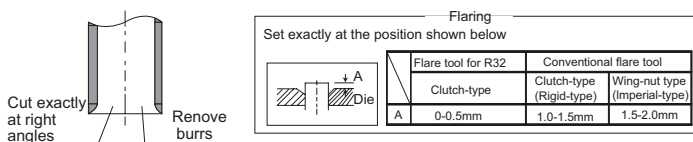

### 8. Connecting the Refrigerant Pipe

(1) Use torque wrenches when tightening the flare nuts to prevent damage to the flare nuts and gas leaks.

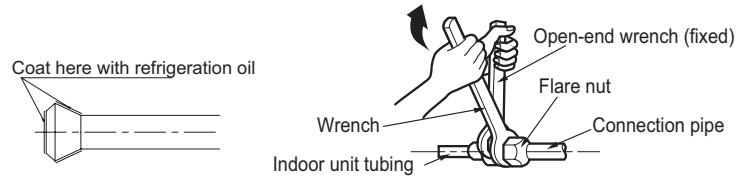

(2) Align the centres of both flares and tighten the flares and tighten the flare nuts 3 or 4 turns by hand.

Then tighten them fully with the torque wrenches.

(3) To prevent gas leakage, apply refrigeration oil on both inner and outer surfaces in the flare. (Use refrigeration oil for R32.)

Hex nut diameter(inch)	Tightening torque(N·m)
1/4	15~20
3/8	30~40
1/2	45~55
5/8	60~65
3/4	70~75

### Caution on Piping Handling

- (1) Protect the open end of the pipe against dust and moisture.
- (2) All pipe bends should be as gentle as possible. Use a pipe bender for bending. (Bending radius should be 30 to 40mm or larger.)

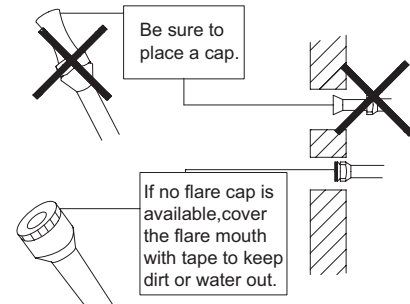

### Selection of Copper and Heat Insulation Materials

When using commercial copper pipes and fittings, observe the following:

- (1) Insulation material: Polyethylene foam  
Heat transfer rate: 0.041 to 0.052W/mK (0.035 to 0.045kcal/(mh°C)  
Refrigerant gas pipes surface temperature reaches 110 max.  
Choose heat insulation materials that will withstand this temperature.

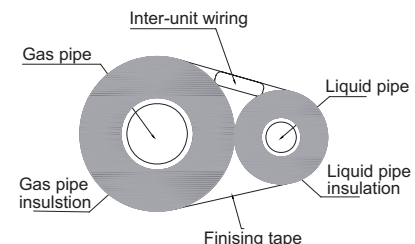

(2) Be sure to insulate both the gas and liquid piping and to provide insulation dimensions as below.

Gas side		Liquid side
09/12K	18K	
O.D. 3/8 inch	O.D. 1/2 inch	O.D. 1/4 inch
Thickness 0.8mm		

Gas pipe thermal insulation		Liquid pipe thermal insulation
09/12K	18K	
I.D. 12-15 mm	I.D. 14-16 mm	I.D. 8-10 mm
Thickness 10mm Min.		

(3) Use separate thermal insulation pipes for gas and liquid refrigerant pipes.

### 9. Checking for Gas Leakage

- (1) Check for leakage of gas after air purging
- (2) See the sections on air purges and gas leak checks in the installation manual for the outdoor unit.

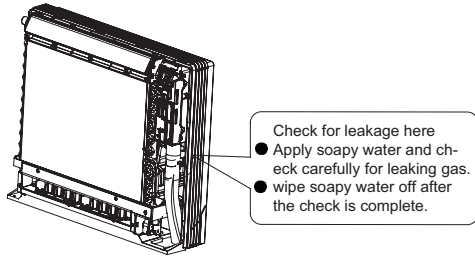

### 10. Attaching the Connection Pipe

- Attach the pipe after checking for gas leakage, described above.
- (1) Cut the insulated portion of the on-site piping, matching it up with the connecting portion.
  - (2) Secure the slit on the refrigerant piping side with the butt joint on the auxiliary piping using the tape, making sure there are no gaps.
  - (3) Wrap the slit and butt joint with the included insulation sheet, making sure there are no gaps.

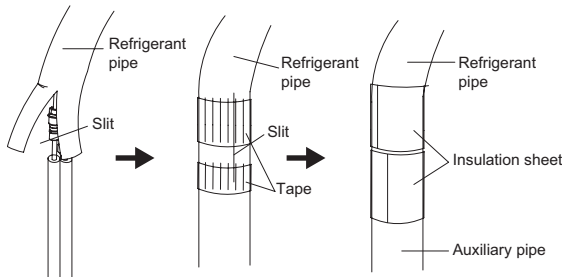

### ⚠ CAUTION

- (1) Insulate the joint of the pipes securely. Incomplete insulation may lead to water leakage.
- (2) Push the pipe inside so it does not place undue force on the front grille.

### 11. Connecting the Drain Hose

Insert the supplied C drain hose into the socket of the drain pan. Fully insert the drain hose until it adheres to a seat of the socket.

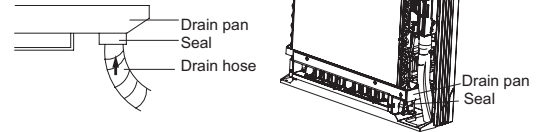

### 12. Wiring

With a Multi indoor unit, install as described in the installation manual supplied with the Multi outdoor unit.

- Live the sensor securing plate, remove the front metal plate cover, and connect the branch wiring to the terminal block.

- (1) Strip wire ends (15mm)
- (2) Match wire colours with terminal numbers on indoor and outdoor units terminal blocks and firmly screw wires to the corresponding terminals.
- (3) Connect the earth wires to the corresponding terminals.
- (4) Pull wires to make sure that they are securely latched up, then retain wires with wire retainer.
- (5) In case of connecting to an adapter system, Run the remote controller cable and attach the S21. (Refer to 11. When connecting go an system.)

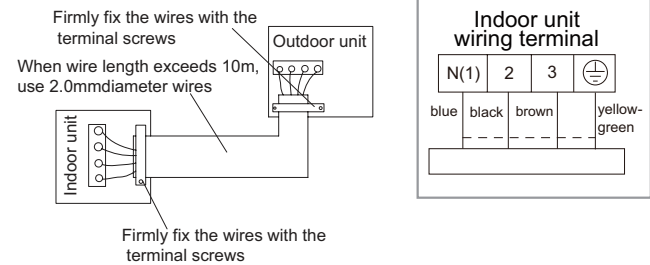
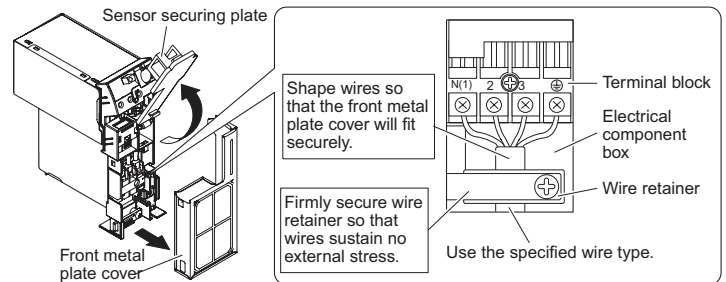

### ⚠ CAUTION

- (1) Do not use tapped wires, stranded wires, extensioncords, or starburst connections, as they may cause overheating, electrical shock, or fire.
- (2) Do not use locally purchased electrical parts inside the product. (Do not branch the power for the drain pump, etc, from the terminal block.) Doing so may cause electric shock or fire.)



## 8.3 Outdoor Unit Installation

### 1. Fix the Support of Outdoor Unit(Select it according to the actual installation situation)

- (1) Select installation location according to the house structure.
- (2) Fix the support of outdoor unit on the selected location with expansion screws.

#### ⚠ CAUTION

- (1) Take sufficient protective measures when installing the outdoor unit.
- (2) Make sure the support can withstand at least four times the unit weight.
- (3) The outdoor unit should be installed at least 3cm above the floor in order to install drain joint.(As show in Fig.A)
- (4) For the unit with cooling capacity of 2300W~5000W, 6 expansion screws are needed; for the unit with cooling capacity of 6000W~8000W, 8 expansion screws are needed; for the unit with cooling capacity of 10000W~16000W, 10 expansion screws are needed.

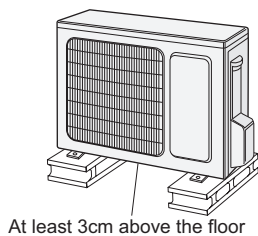

Fig.A

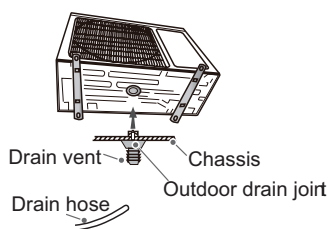

Fig.B

### 2. Install Drain Joint(Only for cooling and heating unit)

- (1) Connect the outdoor drain joint into the hole on the chassis.
- (2) Connect the drain hose into the drain vent.(As show in Fig.B)

### 3. Fix Outdoor Unit

- (1) Place the outdoor unit on the support.
- (2) Fix the foot holes of outdoor unit with bolts.(As show in Fig.C)

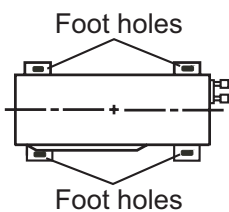

Fig.C

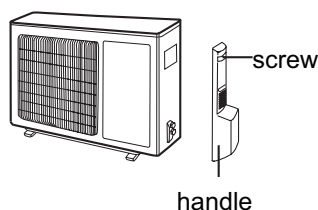

Fig.D

### 4. Connect Indoor and Outdoor Pipes

- (1) Remove the screw on the right handle of outdoor unit and then remove the handle.(As show in Fig.D)
- (2) Remove the screw cap of valve and aim the pipe joint at the bellmouth of pipe.(As show in Fig.E)

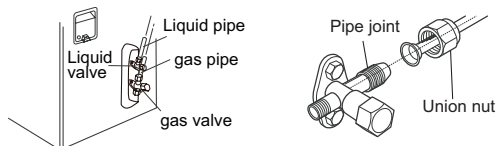

Fig.E

- (3) Pretightening the union nut with hand.
- (4) Tighten the union nut with torque wrench .

Refer to the following table for wrench moment of force:

Hex nut diameter(inch)	Tightening torque(N·m)
1/4	15~20
3/8	30~40
1/2	45~55
5/8	60~65
3/4	70~75

### 5. Connect Outdoor Electric Wire

- (1) Remove the wire clip; connect the power connection wire and signal control wire (only for cooling and heating unit) to the wiring terminal according to the color; fix them with screws.(As show in Fig.F)

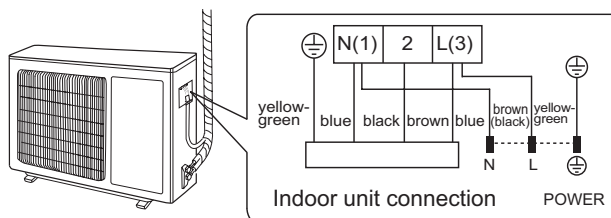

Fig.F

Note: the wiring board is for reference only, please refer to the actual one.

- (2) Fix the power connection wire and signal control wire with wire clip (only for cooling and heating unit).

#### ⚠ Note:

- (1) After tightening the screw, pull the power cord slightly to check if it is firm.
- (2) Never cut the power connection wire to prolong or shorten the distance.

## 8.4 Vacuum Pumping and Leak Detection

### 1. Use Vacuum Pump

- (1) Remove the valve caps on the liquid valve and gas valve and the nut of refrigerant charging vent.
- (2) Connect the charging hose of piezometer to the refrigerant charging vent of gas valve and then connect the other charging hose to the vacuum pump.
- (3) Open the piezometer completely and operate for 10-15min to check if the pressure of piezometer remains in  $-0.1\text{MPa}$ .
- (4) Close the vacuum pump and maintain this status for 1-2min to check if the pressure of piezometer remains in  $-0.1\text{MPa}$ . If the pressure decreases, there may be leakage.
- (5) Remove the piezometer, open the valve core of liquid valve and gas valve completely with inner hexagon spanner.
- (6) Tighten the screw caps of valves and refrigerant charging vent.

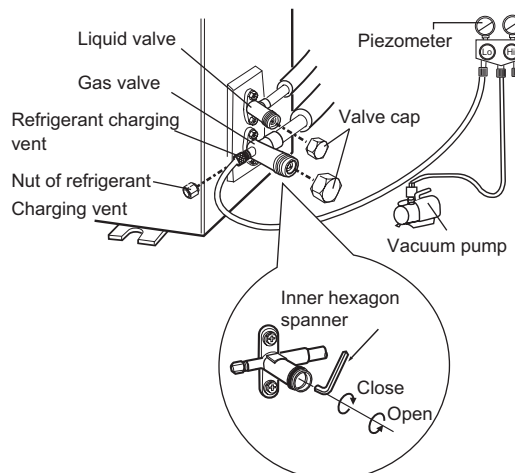

## 2. Leakage Detection

(1) With leakage detector:

Check if there is leakage with leakage detector.

(2) With soap water:

If leakage detector is not available, please use soap water for leakage detection. Apply soap water at the suspected position and keep the soap water for more than 3min. If there are air bubbles coming out of this position, there's a leakage.

## 8.5 Check after Installation and Test Operation

### 1. Check after Installation

Check according to the following requirement after finishing installation.

NO.	Items to be checked	Possible malfunction
1	Has the unit been installed firmly?	The unit may drop, shake or emit noise.
2	Have you done the refrigerant leakage test?	It may cause insufficient cooling (heating) capacity.
3	Is heat insulation of pipeline sufficient?	It may cause condensation and water dripping.
4	Is water drained well?	It may cause condensation and water dripping.
5	Is the voltage of power supply according to the voltage marked on the nameplate?	It may cause malfunction or damage the parts.
6	Is electric wiring and pipeline installed correctly?	It may cause malfunction or damage the parts.
7	Is the unit grounded securely?	It may cause electric leakage.
8	Does the power cord follow the specification?	It may cause malfunction or damage the parts.
9	Is there any obstruction in air inlet and air outlet?	It may cause insufficient cooling (heating) capacity.
10	The dust and sundries caused during installation are removed?	It may cause malfunction or damaging the parts.
11	The gas valve and liquid valve of connection pipe are open completely?	It may cause insufficient cooling (heating) capacity.
12	Is the inlet and outlet of piping hole been covered?	It may cause insufficient cooling (heating) capacity or waster eletricity.

### 2. Test Operation

(1) Preparation of test operation

- The client approves the air conditioner installation.
- Specify the important notes for air conditioner to the client.

(2) Method of test operation

- Put through the power, press ON/OFF button on the remote controller to start operation.
- Press MODE button to select AUTO, COOL, DRY, FAN and HEAT to check whether the operation is normal or not.
- If the ambient temperature is lower than 16°C , the air conditioner cant start cooling.

# 9. Maintenance

## 9.1 Error Code List

Error code	Malfunction name	AC status	Possible causes
<b>E5</b>	Malfunction of jumper cap	The complete unit stops operation	<ol style="list-style-type: none"> <li>1. Jumper cap is not installed in control panel;</li> <li>2. Poor contact of jumper cap;</li> <li>3. Jumper cap is damaged;</li> <li>4. The tested circuit of jumper cap on control panel is abnormal.</li> </ol>
<b>E6</b>	Communication malfunction between indoor unit and outdoor unit	Cool: compressor stops operation, while indoor fan operates; Heat: all loads stops operation.	See "Communication malfunction"
<b>H5</b>	IPM protection	Cool/Dry: compressor stops operation, while indoor fan operates. Heat: all loads stops operation.	See "IPM protection, over-phase current of compressor"
<b>L3 LA</b>	Malfunction of outdoor fan/ malfunction of DC motor	Cool/Dry: all loads stops operation except indoor fan. Heat: all loads stops operation.	<ol style="list-style-type: none"> <li>1. Outdoor condenser, air inlet and air outlet are blocked by filth or dirt;</li> <li>2. Fan is blocked or loosened;</li> <li>3. Motor or connection wire of motor is damaged;</li> <li>4. Main board of outdoor unit is damaged;</li> </ol> (As for dual-outdoor fan, L3 indicates fan 1; LA indicates fan 2)
<b>H3</b>	Overload protection of compressor	Cool/Dry: compressor stops operation, while indoor fan operates. Heat: all loads stops operation.	<ol style="list-style-type: none"> <li>1. Overload wire of compressor is loose;</li> <li>2. The overload protector is damaged. Under normal circumstances, the resistance between both ends of terminal is less than 1ohm.</li> <li>3. See "Overload protection of compressor , High discharge temperature protection of compressor"</li> </ol>
<b>F0</b>	Refrigerant insufficient protection, cut-off protection of refrigerant	Cool: compressor and outdoor fan stops operation, while indoor fan operates; Heat: Compressor, outdoor fan and indoor fan stops operation.	<ol style="list-style-type: none"> <li>1. Is system cooling under high humidity environment, thus temperature difference of heat transfer is small;</li> <li>2. Check whether the big valve and small valve of outdoor unit are opened completely;</li> <li>3. Is the temperature sensor of evaporator of indoor unit loose?</li> <li>4. Is the temperature sensor of condenser of outdoor unit loose?</li> <li>5. Is the capillary or the electronic expansion valve blocked?</li> <li>6. Is refrigerant leaking?</li> </ol>
<b>F1</b>	Indoor ambient temperature sensor is open/short-circuited	Cool/Dry: indoor fan operates, while compressor and outdoor fan stops operation; Heat: all loads stops operation.	<ol style="list-style-type: none"> <li>1. Temperature sensor is not well connected;</li> <li>2. Temperature sensor is damaged</li> <li>3. Main board of indoor unit is damaged.</li> </ol>
<b>F2</b>	Indoor evaporator temperature sensor is open/short-circuited	Cool/Dry: indoor fan operates, while compressor and outdoor fan stops operation; Heat: all loads stops operation.	<ol style="list-style-type: none"> <li>1. Temperature sensor is not well connected;</li> <li>2. Temperature sensor is damaged</li> <li>3. Main board of indoor unit is damaged.</li> </ol>
<b>H6</b>	No feedback from indoor unit's motor	The complete unit stops operation	<ol style="list-style-type: none"> <li>1. Is the fan blocked?</li> <li>2. Is the motor terminal loose?</li> <li>3. Is the connection wire of motor damaged?</li> <li>4. Is the motor damaged?</li> <li>5. Is the main board of indoor unit damaged?</li> </ol>
<b>LP</b>	Indoor unit and outdoor can be matched with each other	Heat: compressor, outdoor unit and indoor fan stops operation.	Capacity of indoor unit and outdoor unit can't be matched.
<b>C4</b>	Malfunction of jumper cap of outdoor unit	Heat: all loads are stopped; other modes: outdoor unit stops operation.	Jumper cap of outdoor unit hasn't been installed.
<b>b7</b>	Gas valve temperature sensor is ON / short-circuited		<ol style="list-style-type: none"> <li>1. Temperature sensor is not well connected or damaged;</li> <li>2. The wire of temperature sensor is damaged, causing short circuit to copper pipe or outer casing;</li> <li>3. Main board of outdoor unit is damaged.</li> </ol>

Error code	Malfunction name	AC status	Possible causes
<b>b5</b>	Liquid valve temperature sensor is ON / short-circuited		<ol style="list-style-type: none"> <li>1. Temperature sensor is not well connected or damaged;</li> <li>2. The wire of temperature sensor is damaged, causing short circuit to copper pipe or outer casing;</li> <li>3. Main board of outdoor unit is damaged.</li> </ol>
<b>E1</b>	High pressure protection of system	Cool/Dry: all loads stops operation except indoor fan; Heat: all loads stops operation.	<ol style="list-style-type: none"> <li>1. Heat exchange of outdoor unit is too dirty, or it blocked the air inlet/outlet;</li> <li>2. Is power voltage normal; (three-phase unit)</li> <li>3. Ambient temperature is too high;</li> <li>4. Wiring of high pressure switch is loose or high pressure switch is damaged;</li> <li>5. The internal system is blocked; (dirt blockage, ice blockage, oil blockage, angle valve is not completely opened)</li> <li>6. Main board of outdoor unit is damaged;</li> <li>7. Refrigerant is too much.</li> </ol>
<b>E3</b>	Low pressure/low system pressure protection/ compressor low pressure protection	Cool: compressor, outdoor fan and indoor fan stop operation; Heat: compressor and outdoor fan stop operation at first. About 1min later, indoor fan stops operation; 2mins later, the 4-way valve stop operation.	<ol style="list-style-type: none"> <li>1. Low pressure switch is damaged;</li> <li>2. Refrigerant inside the system is insufficient.</li> </ol>
<b>E4</b>	High discharge temperature protection of compressor	Cool/Dry: compressor and outdoor fan stops operation, while indoor fan operates; Heat: all loads stops operation.	See "Overload protection of compressor , High discharge temperature protection of compressor"
<b>E5</b>	AC overcurrent protection	Cool/Dry: compressor and outdoor fan stops operation, while indoor fan operates; Heat: all loads stops operation.	<ol style="list-style-type: none"> <li>1. Power voltage is unstable;</li> <li>2. Power voltage is too low;</li> <li>3. System load is too high, which leads to high current;</li> <li>4. Heat exchange of indoor unit is too dirty, or it blocked the air inlet/outlet;</li> <li>5. Fan motor operation is abnormal; the fan speed is too low or not functioning;</li> <li>6. Compressor is blocked;</li> <li>7. The internal system is blocked; (dirt blockage, ice blockage, oil blockage, angle valve is not completely opened)</li> <li>8. Main board of outdoor unit is damaged.</li> </ol> See "AC overcurrent protection"
<b>E7</b>	Mode shock/sysmte mode shock	Load of indoor unit stops operation (indoor fan, E-heater, swing)	Malfunction of one-to-more system; there may be two indoor units which has set the shock mode, such as one is cooling and the other is heating.
<b>E8</b>	High temperature prevention protection	Cool: compressor stops operation while indoor fan operates; Heat: all loads stops operation.	See "High temperature prevention protection; high power; system isabnormal"
<b>EE</b>	Malfunction of EEPROM	Cool/Dry: compressor stops operation, while indoor fan operates; Heat: all loads stops operation.	Main board of outdoor unit is damaged.
<b>Fo</b>	Refrigerant-recovery mode	Cool/Dry: compressor and outdoor fan stops operation, while indoor fan operates.	Refrigerant recovery. The maintenance personnel operate it when he is maintaining the unit.
<b>F3</b>	Outdoor ambient temperature is open/short-circuited	Cool/Dry: compressor and outdoor fan stop operation, while indoor fan operates; Heat: all loads stops operation.	<ol style="list-style-type: none"> <li>1. Temperature sensor is not connected well or damaged;</li> <li>2. Temperature sensor wire of outdoor unit is damaged; short circuit between the temperature sensor and copper pipe or outer case</li> <li>3. Main board of outdoor unit is damaged;</li> </ol>

Error code	Malfunction name	AC status	Possible causes
F4	Outdoor condenser temperature sensor is open/short-circuited	Cool/Dry: compressor and outdoor fan stop operation, while indoor fan operates; Heat: after operating for 3mins, all loads stops operation.	1. Temperature sensor is not connected well or damaged; 2. Temperature sensor wire of outdoor unit is damaged; short circuit between the temperature sensor and copper pipe or outer case; 3. Main board of outdoor unit is damaged.
F5	Outdoor air discharge temperature is open/short-circuited	Complete unit stops operation; motor of sliding door is cut off power.	1. The exhaust temperature sensor is not connected well or damaged. 2. Temperature sensor wire of outdoor unit is damaged; short circuit between the temperature sensor and copper pipe or outer case 3. Main board of outdoor unit is damaged;
FC	Malfunction of micro switch	Cool/Dry: compressor stops operation, while indoor fan operates; Heat: all loads stops operation.	1. The sliding door is blocked; 2. Malfunction of the photoelectric inspection panel of sliding door;
H4	System is abnormal	Cool/Dry: all loads stops operation except indoor fan; Heat: all loads stops operation.	See "High temperature prevention protection; high power; system is abnormal"
H7	Desynchronizing of compressor	Cool/Dry: compressor stops operation, while indoor fan operates; Heat: all loads stops operation.	See "Desynchronization diagnosis for compressor"
HC	PFC protection	Cool/Dry: compressor stops operation, while indoor fan operates; Heat: all loads stops operation.	1. The power grid quality is bad; AC input voltage fluctuates sharply; 2. Power plug of air conditioner or wiring board or reactor is not connected reliably; 3. Indoor and outdoor heat exchanger is too dirty, or air inlet/outlet is blocked; 4. Main board of outdoor unit is damaged.
HE	Demagnetization protection of compressor	Cool: compressor and outdoor fan stop operation; Heat: compressor and outdoor fan stop operation at first; about 1min later, indoor fan stops operation.	1. The main board of outdoor unit is damaged; 2. Compressor is damaged;
UF	Communication malfunction between indoor unit and inspection board	Normal operation	1. Poor connection between the indoor unit and the inspection board. 2. The main board of indoor unit is damaged; 3. The inspection board is damaged;
L1	Malfunction of humidity sensor	Compressor, outdoor fan and indoor fan stop operation;	The inspection board is damaged.
L9	High power protection	Cool: compressor and outdoor fan stops operation, while indoor fan operates.	See "High temperature prevention protection; high power; system is abnormal"
Lc	Start-up failed	Cool/Dry: compressor stops, while indoor fan operates; Heat: all loads stops operation.	See "Malfunction diagnosis for failure startup"
Ld	Lost phase	Cool: compressor and outdoor fan stop operation; Heat: compressor and outdoor fan stop operation at first; about 1min later, indoor fan stops operation.	1. The main board of outdoor unit is damaged; 2. The compressor is damaged; 3. The connection wire of compressor is not connected well.
PS	Over-phase current protection of compressor	Cool/Dry: compressor stops operation, while indoor fan operates; Heat: all loads stops operation.	See "Overload protection of compressor , High discharge temperature protection of compressor"

Error code	Malfunction name	AC status	Possible causes
<b>OE</b>	Undefined outdoor unit error	Cool: compressor and outdoor fan stops operation, while indoor fan operates; Heat: compressor, outdoor fan and indoor fan stop operation.	<ol style="list-style-type: none"> <li>1. Outdoor ambient temperature exceeds the operation range of unit (eg: less than -20°C or more than 60°C for cooling; more than 30°C for heating);</li> <li>2. Are wires of compressor not connected tightly?</li> <li>3. Failure startup of compressor?</li> <li>4. Is compressor damaged?</li> <li>5. Is main board damaged?</li> </ol>
<b>PE</b>	Communication malfunction between the drive board and the main board	Cool: compressor and outdoor fan stops operation; Heat: compressor and outdoor fan stop at first; about 1min later, indoor fan stops operation;	<ol style="list-style-type: none"> <li>1. The drive board is damaged;</li> <li>2. The main board of outdoor unit is damaged;</li> <li>3. The drive board and the main board is not connected well.</li> </ol>
<b>PE</b>	Circuit malfunction of module temperature sensor	Cool/Dry: compressor stops operation, while indoor fan operates; Heat: all loads stops operation.	Replace outdoor control board
<b>PE</b>	Module overheating protection	Cool: compressor stops operation, while indoor fan operates; Heat: all loads stops operation.	<ol style="list-style-type: none"> <li>1. Air inlet / air outlet of outdoor unit are blocked by filth or dirt;</li> <li>2. Condenser of outdoor unit is blocked by filth or dirt;</li> <li>3. IPM screw of main board is not tightened;</li> <li>4. Main board of outdoor unit is damaged;</li> </ol>
<b>PE</b>	Malfunction of ambient temperature sensor of drive board	Cool: compressor, outdoor fan and indoor fan stop operation; Heat: compressor and outdoor fan stop operation at first; about 1min later, indoor fan stops operation.	<ol style="list-style-type: none"> <li>1. The ambient temperature sensor of the drive board is not connected well;</li> <li>2. Malfunction of the ambient temperature sensor of drive board.</li> </ol>
<b>PH</b>	DC bus voltage is too high	Cool/Dry: compressor stops operation, while indoor fan operates; Heat: all loads stops operation.	<ol style="list-style-type: none"> <li>1. Measure the voltage between position L and position N on the wiring board (XT). If it's higher than 265 VAC, please turn on the unit until the power voltage is decreased to the normal range;</li> <li>2. If the AC input is normal, please replace the outdoor control board.</li> </ol>
<b>PL</b>	DC bus voltage is too low	Cool/Dry: compressor stops operation, while indoor fan operates; Heat: all loads stops operation.	<ol style="list-style-type: none"> <li>1. Measure the voltage between position L and position N on the wiring board (XT). If it's lower than 150 VAC, please turn on the unit until the power voltage is increased to the normal range;</li> <li>2. If the AC input is normal, please replace the outdoor control board.</li> </ol>
<b>PU</b>	Charging malfunction of capacitor	Cool/Dry: compressor stops operation, while indoor fan operates; Heat: all loads stops operation.	See "Charging malfunction of capacitor"
<b>RF</b>	Malfunction of RF module	Cool: compressor and outdoor fan stop operation; Heat: compressor and outdoor fan stop operation at first; about 1min later, indoor fan stops operation.	<ol style="list-style-type: none"> <li>1. The connection wire of RF module is not connected well.</li> <li>2. Malfunction of RF module;</li> </ol>
<b>U1</b>	Phase current detection circuit malfunction of	Cool: compressor and outdoor fan stops operation, while indoor fan operates; Heat: compressor, outdoor fan and indoor fan stops operation.	The control board is damaged
<b>U2</b>	Lost phase protection of compressor	Cool: compressor and outdoor fan stop operation; Heat: compressor and outdoor fan stop operation at first; about 1min later, indoor fan stops operation.	<ol style="list-style-type: none"> <li>1. The main board of outdoor unit is damaged;</li> <li>2. The compressor is damaged;</li> <li>3. The connection wire of compressor is not connected well.</li> </ol>

Error code	Malfunction name	AC status	Possible causes
U3	DC bus voltage drop malfunction	Cool/Dry: compressor stops operation, while indoor fan operates; Heat: all loads stops operation.	The power voltage is unstable.
U5	Current detection malfunction of unit	Cool: compressor and outdoor fan stops operation, while indoor fan operates; Heat: compressor, outdoor fan and indoor fan stops operation.	1. Is the complete unit lacking of refrigerant? 2. There's malfunction for the circuit of control board of outdoor unit. Replace the control board of outdoor unit.
U7	4-way valve is abnormal	This malfunction occurs when the unit is heating. All loads stops operation.	1. Power voltage is lower than AC175V; 2. Wiring terminal of 4-way valve is loose or broken; 3. 4-way valve is damaged. Replace the 4-way valve.
U8	Malfunction of zero-crossing signal of indoor unit	Compressor, outdoor fan and indoor fan stop operation.	1. The power is abnormal; 2. Main board of indoor unit is damaged.
U9	Zero-crossing malfunction of outdoor unit	Cool: compressor stops operation, while indoor fan operates; Heat: all loads stops operation.	Replace the control board of outdoor unit.
E2	Evaporator anti-freezing protection		Not error code, it is the status code in cooling process
E9	Anti cold air protection		Not error code, it is the status code in cooling process
	Defrosting	Heat indicator Flash once/10s	Not error code, it is the status code in cooling process

### Analysis or processing of some of the malfunction display:

#### 1. Compressor discharge protection

Possible causes: shortage of refrigerant; blockage of air filter; poor ventilation or air flow short pass for condenser; the system has noncondensing gas (such as air, water etc.); blockage of capillary assy (including filter); leakage inside four-way valve causes incorrect operation; malfunction of compressor; malfunction of protection relay; malfunction of discharge sensor; outdoor temperature too high.

Processing method: refer to the malfunction analysis in the above section.

#### 2. Low voltage overcurrent protection

Possible cause: Sudden drop of supply voltage.

#### 3. Communication malfunction

Processing method: Check if communication signal cable is connected reliably.

#### 4. Sensor open or short circuit

Processing method: Check whether sensor is normal, connected with the corresponding position on the controller and if damage of lead wire is found.

#### 5. Compressor over load protection

Possible causes: insufficient or too much refrigerant; blockage of capillary and increase of suction temp.; improper running of compressor, burning in or stuck of bearing, damage of discharge valve; malfunction of protector.

Processing method: adjust refrigerant amount; replace the capillary; replace the compressor; use universal meter to check if the contactor of compressor is fine when it is not overheated, if not replace the protector.

#### 6. System malfunction

i.e. overload protection. When tube temperature (Check the temperature of outdoor heat exchanger when cooling and check the temperature of indoor heat exchanger when heating) is too high, protection will be activated.

Possible causes: Outdoor temperature is too high when cooling; insufficient outdoor air circulation; refrigerant flow malfunction.

please refer to the malfunction analysis in the previous section for handling method.

#### 7. IPM module protection

Processing method: Once the module malfunction happens, if it persists for a long time and can not be self-canceled, cut off the power and turn off the unit, and then re-energize the unit again after about 10 min. After repeating the procedure for several times, if the malfunction still exists, replace the module.

## 9.2 Procedure of Troubleshooting

### 1. Troubleshooting for jumper cap C5

Main check points:

(1) jumper cap (2) control board of indoor unit

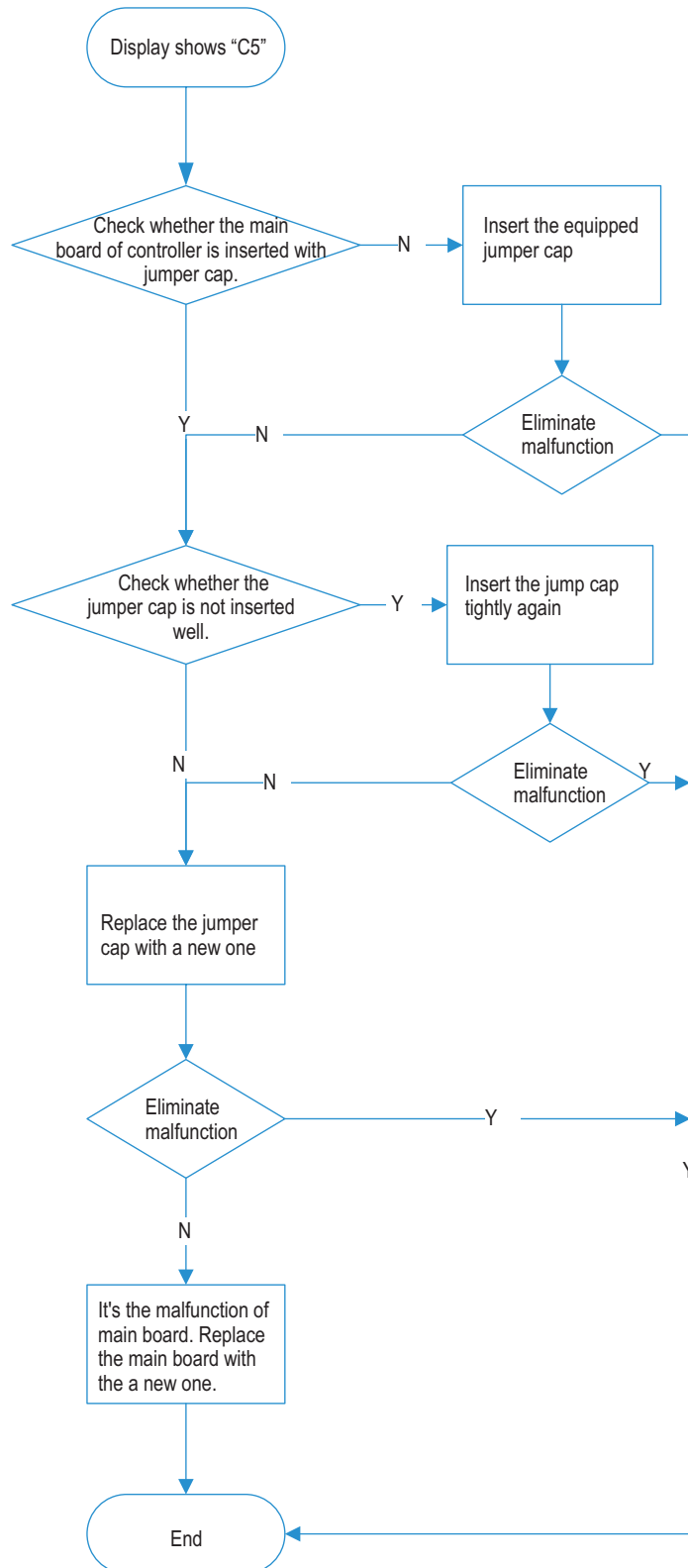



## 2. Communication malfunction EE

Main check points:

- (1) Connection wire between indoor unit and outdoor unit
- (2) Wiring inside the unit
- (3) Communication circuit of control board of indoor unit
- (4) Communication circuit of control board of outdoor unit

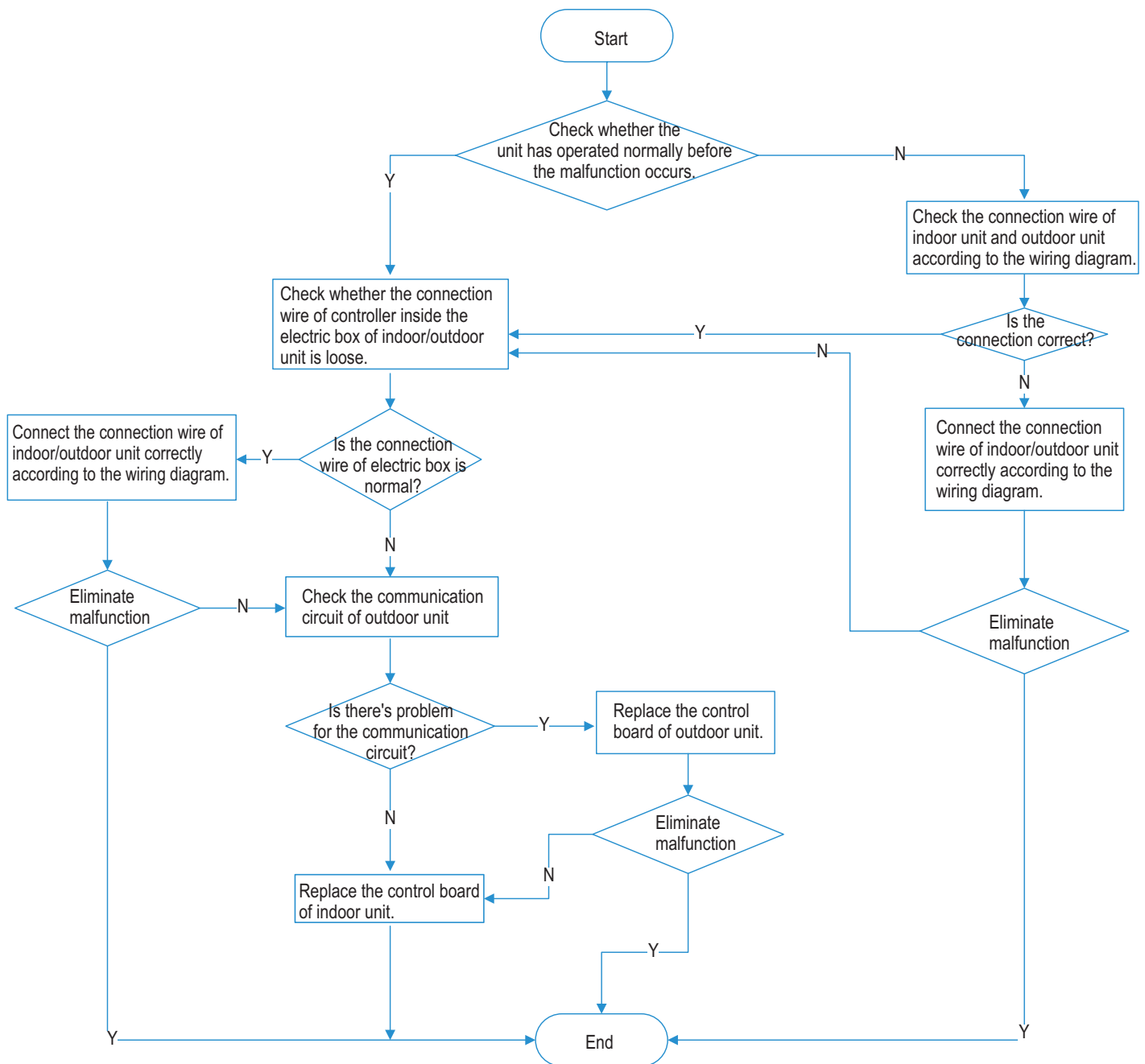

### 3. IPM protection H5, over-phase current of compressor P5

Main check points:

- (1) compressor COMP terminal
- (2) power supply voltage
- (3) compressor
- (4) charging amount of refrigerant
- (5) air inlet and air outlet of indoor/outdoor unit

NOTE: The control board as below means the control board of outdoor unit.

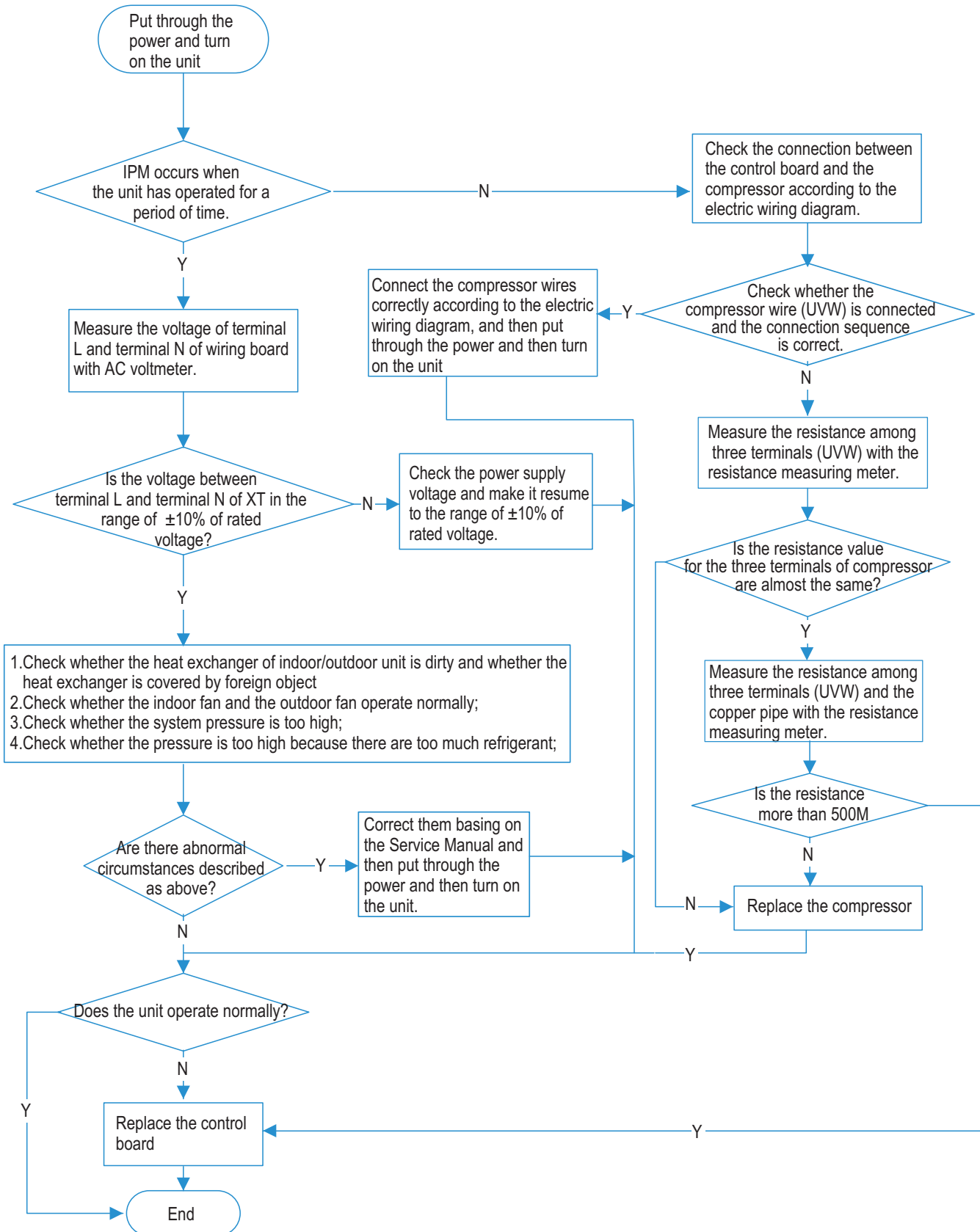

## 4. Overload protection of compressor H3, high discharge temperature, protection of compressor E4

Main check points:

- (1) electronic expansion valve (2) expansion valve terminal
- (3) charging amount of refrigerant (4) overload protector

NOTE: The control board as below means the control board of outdoor unit.

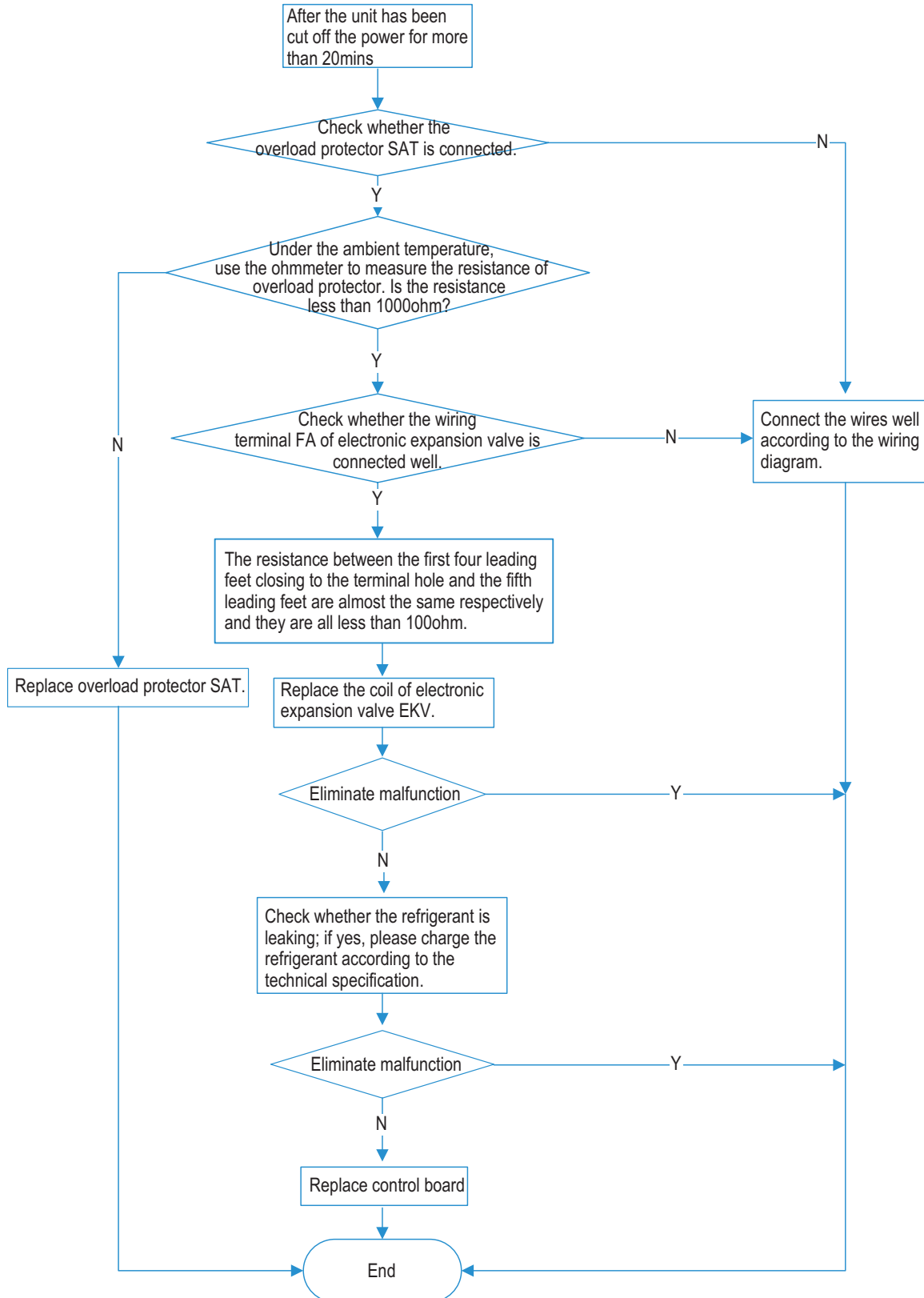

## 5. Troubleshooting for temperature sensor F1, F2, F3, F4, F5

Main check points:

(1) connection terminal (2) temperature sensor (3) main board

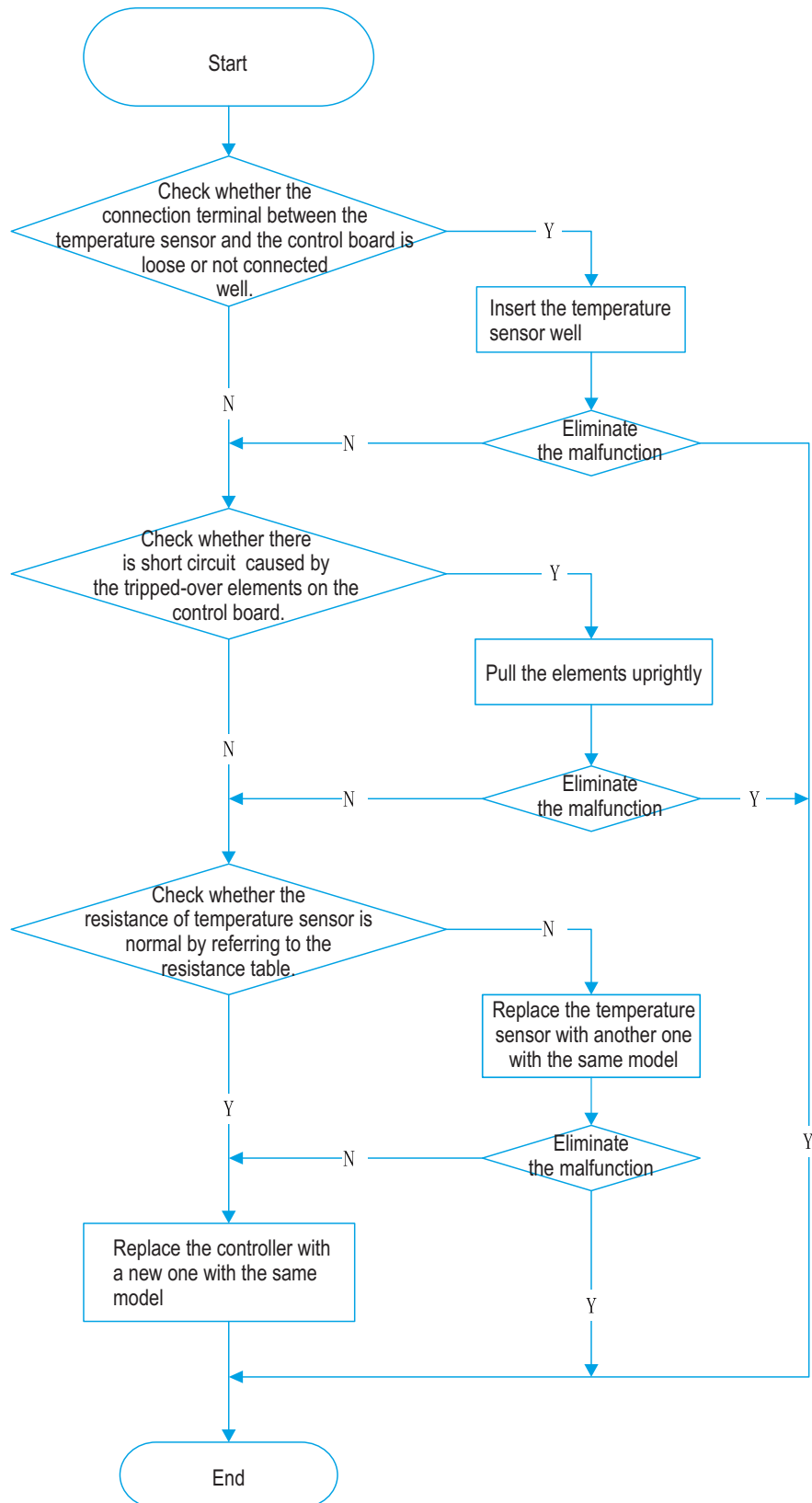

## 6.High temperature prevention protection 故障; high power 故障; system is abnormal 故障

Main check points:

(1) outdoor temperature (2) fan (3)air inlet and air outlet of indoor/outdoor unit

NOTE:The control board as below means the control board of outdoor unit.

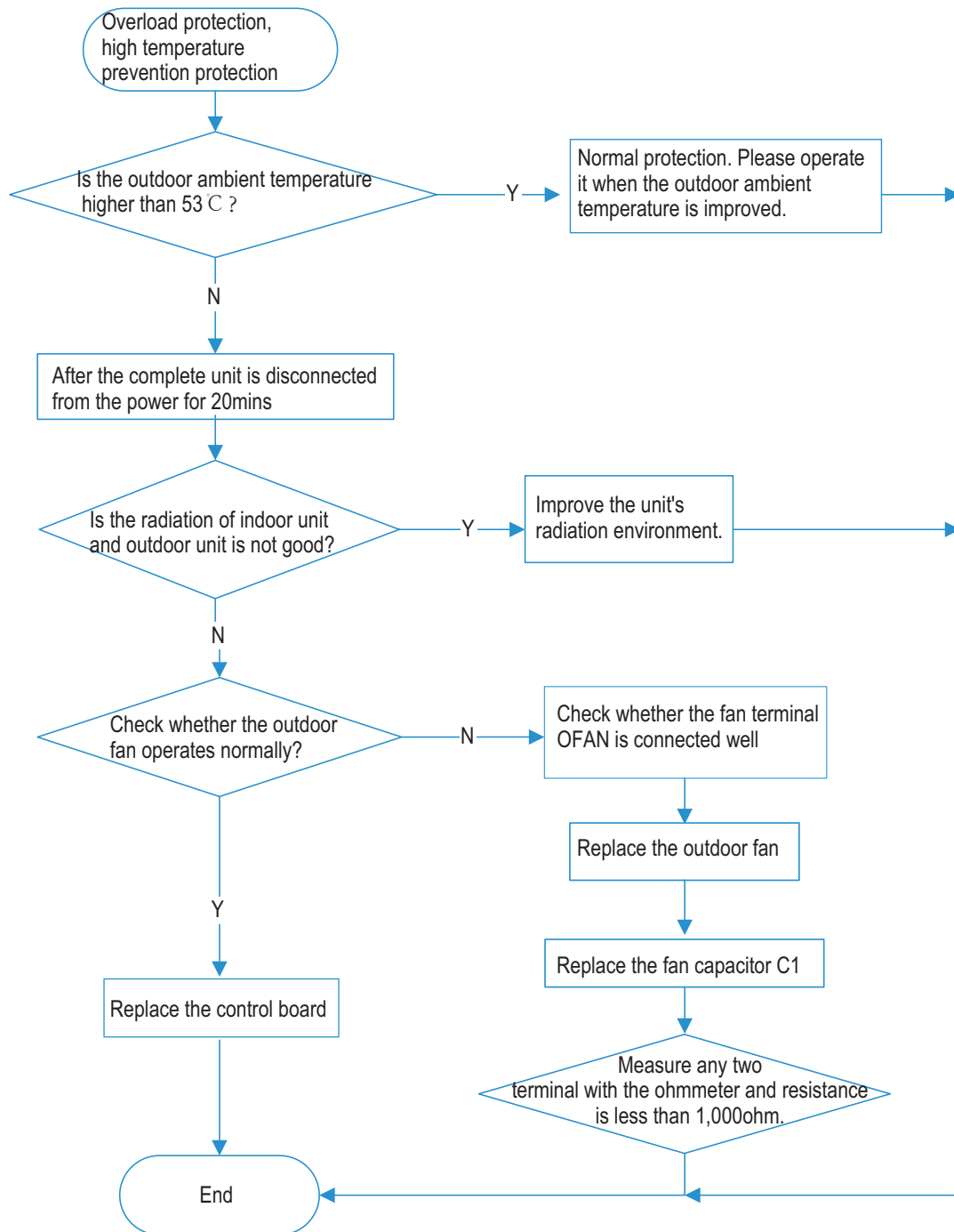

## 7.Desynchronization diagnosis for compressor H 7

Main check point:

(1) system pressure (2) power supply voltage

NOTE:The control board as below means the control board of outdoor unit.

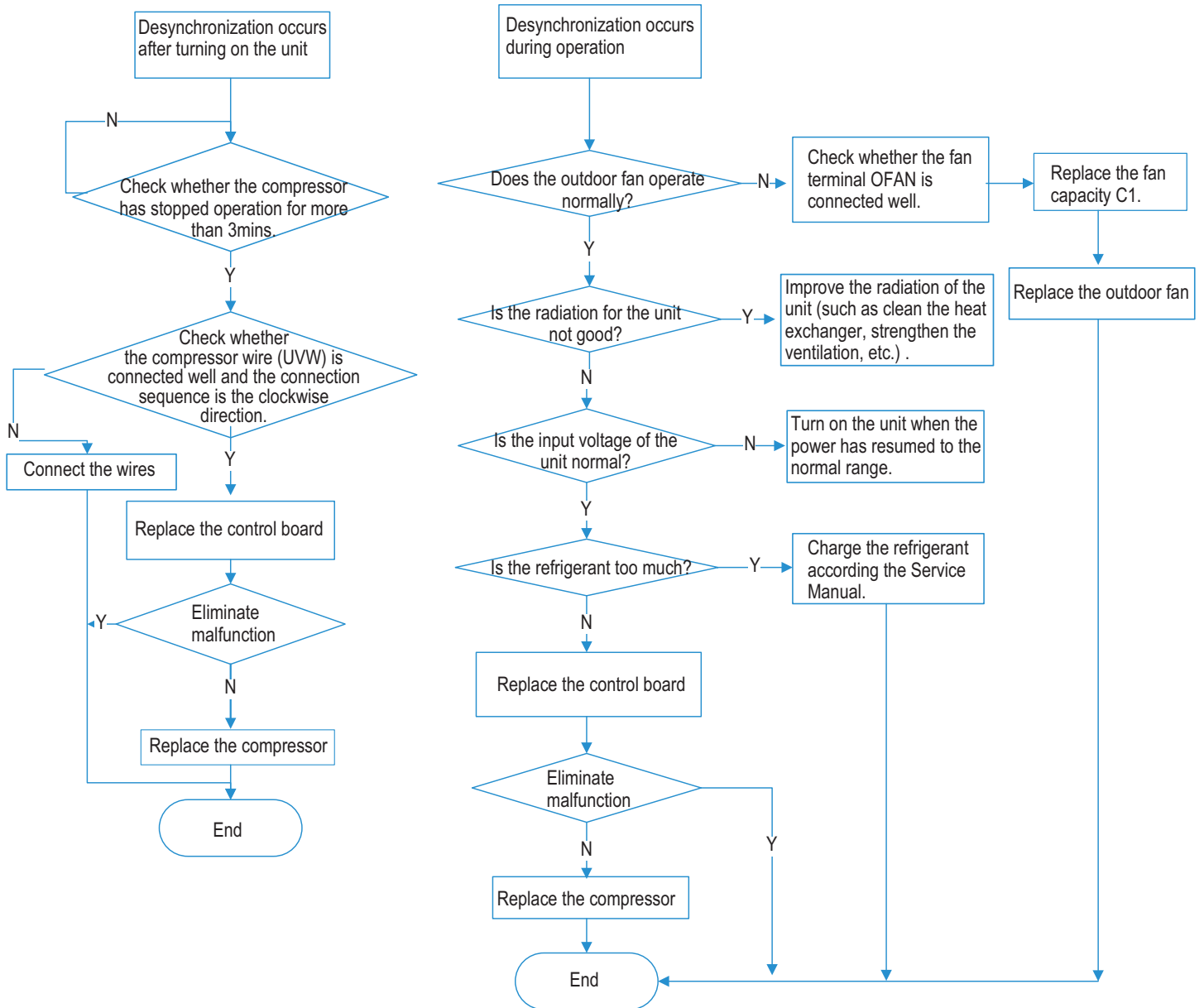

## 8. Malfunction diagnosis for failure startup

Main check points:

(1) compressor wire (2) compressor (3) charging amount of refrigerant

NOTE: The control board as below means the control board of outdoor unit.

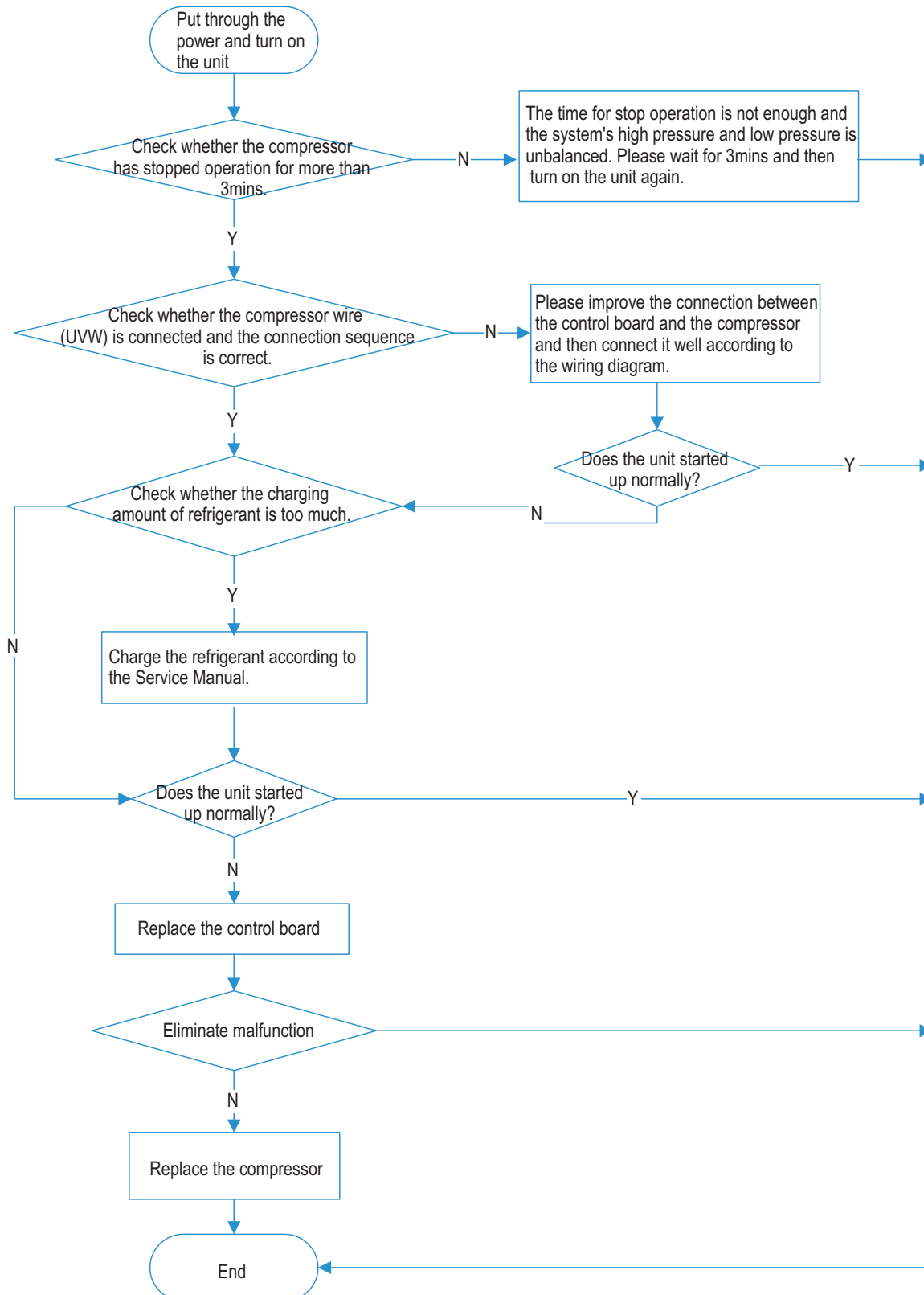

## 9. Charging malfunction of capacitor PU

Main check points:

(1) wiring board XT (2) reactor

NOTE: The control board as below means the control board of outdoor unit.

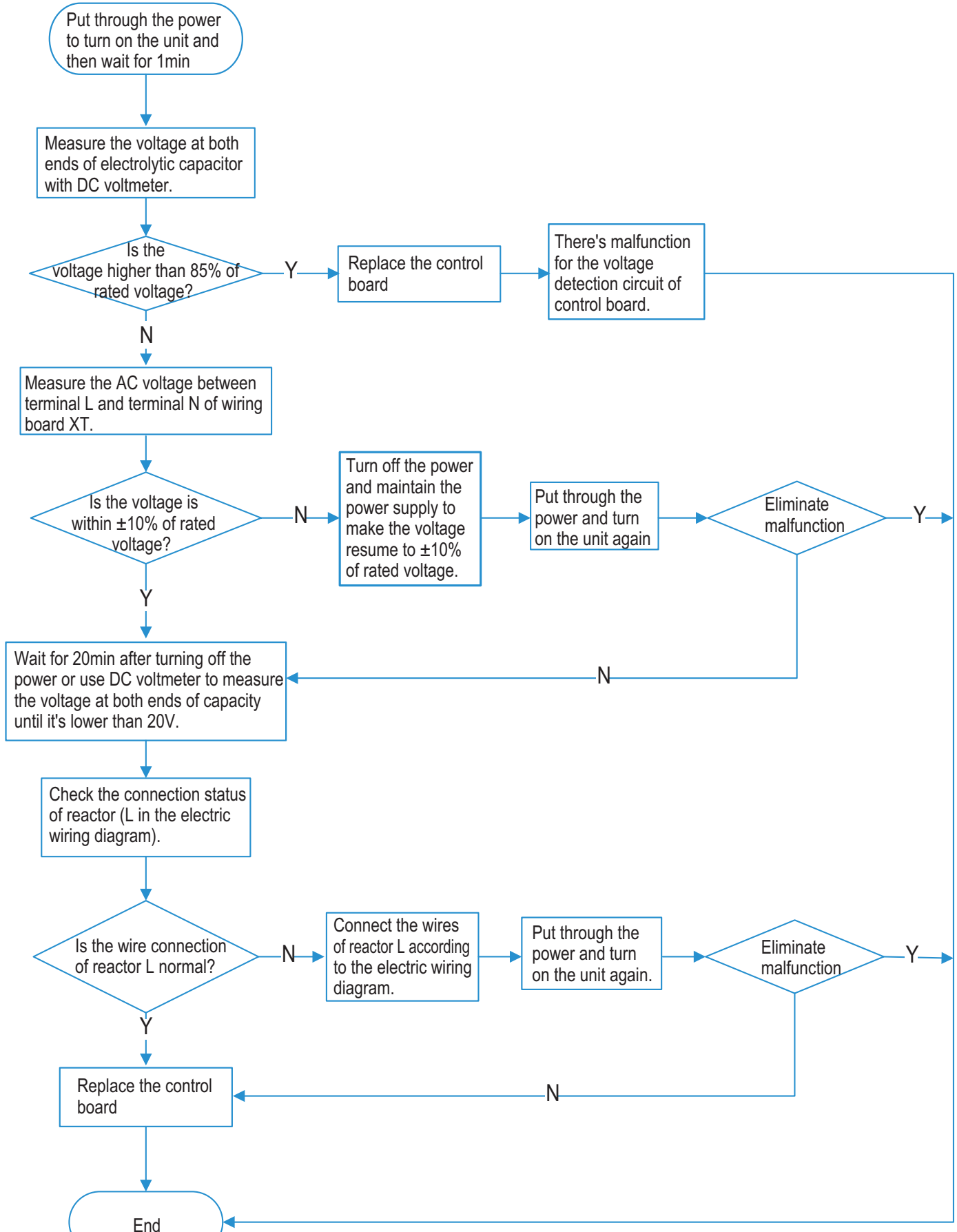



## 10. Troubleshooting-motor(indoor fan) doesn't operate H5

Main check points:

(1) connection terminal (2) motor (3) control board AP1 of indoor unit (4) blade

### 10.1 DC motor

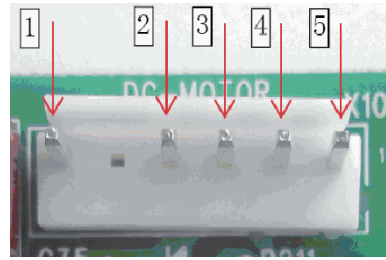
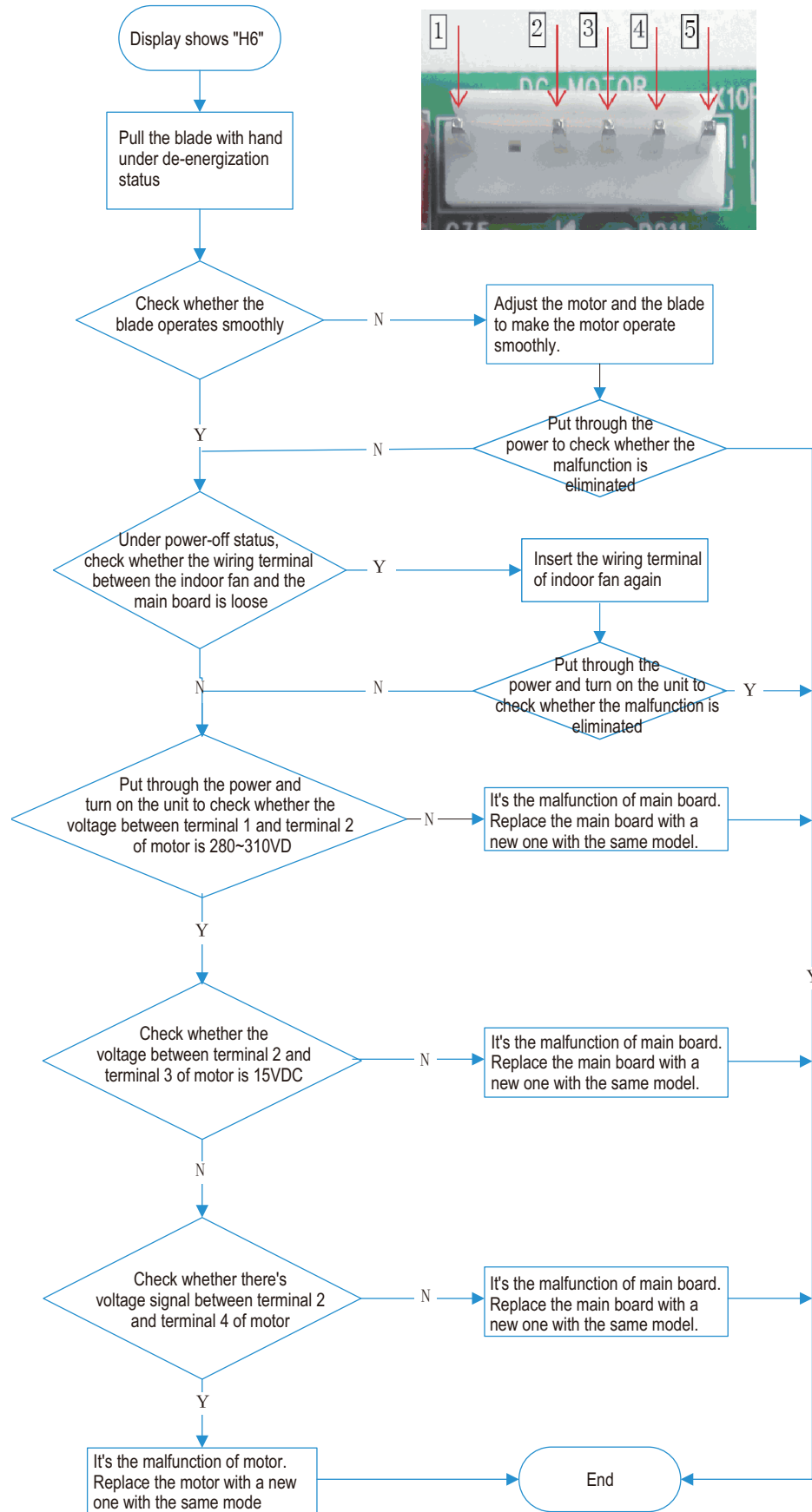

## 10.2 PG motor

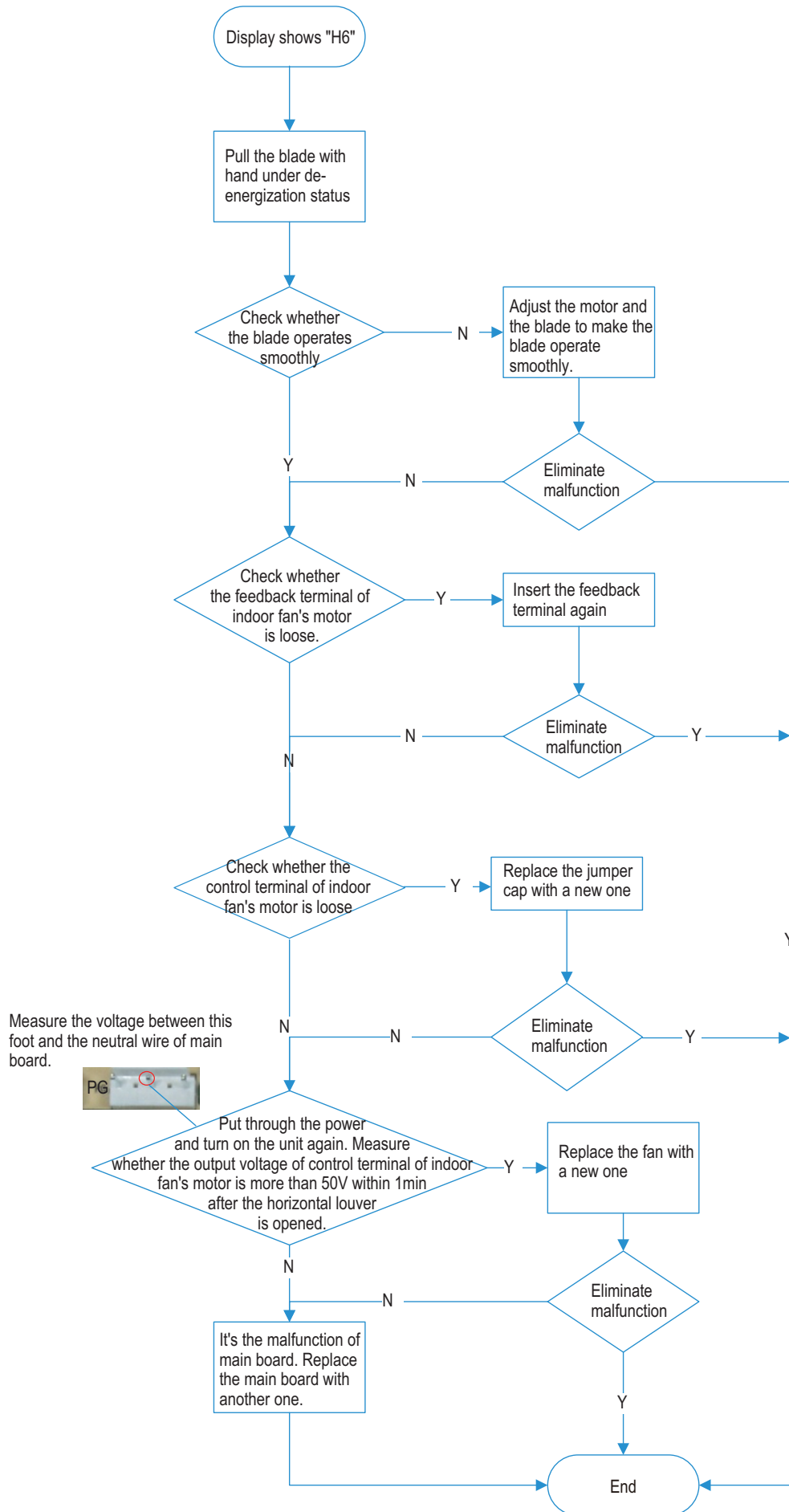

## 11. AC overcurrent protection E5

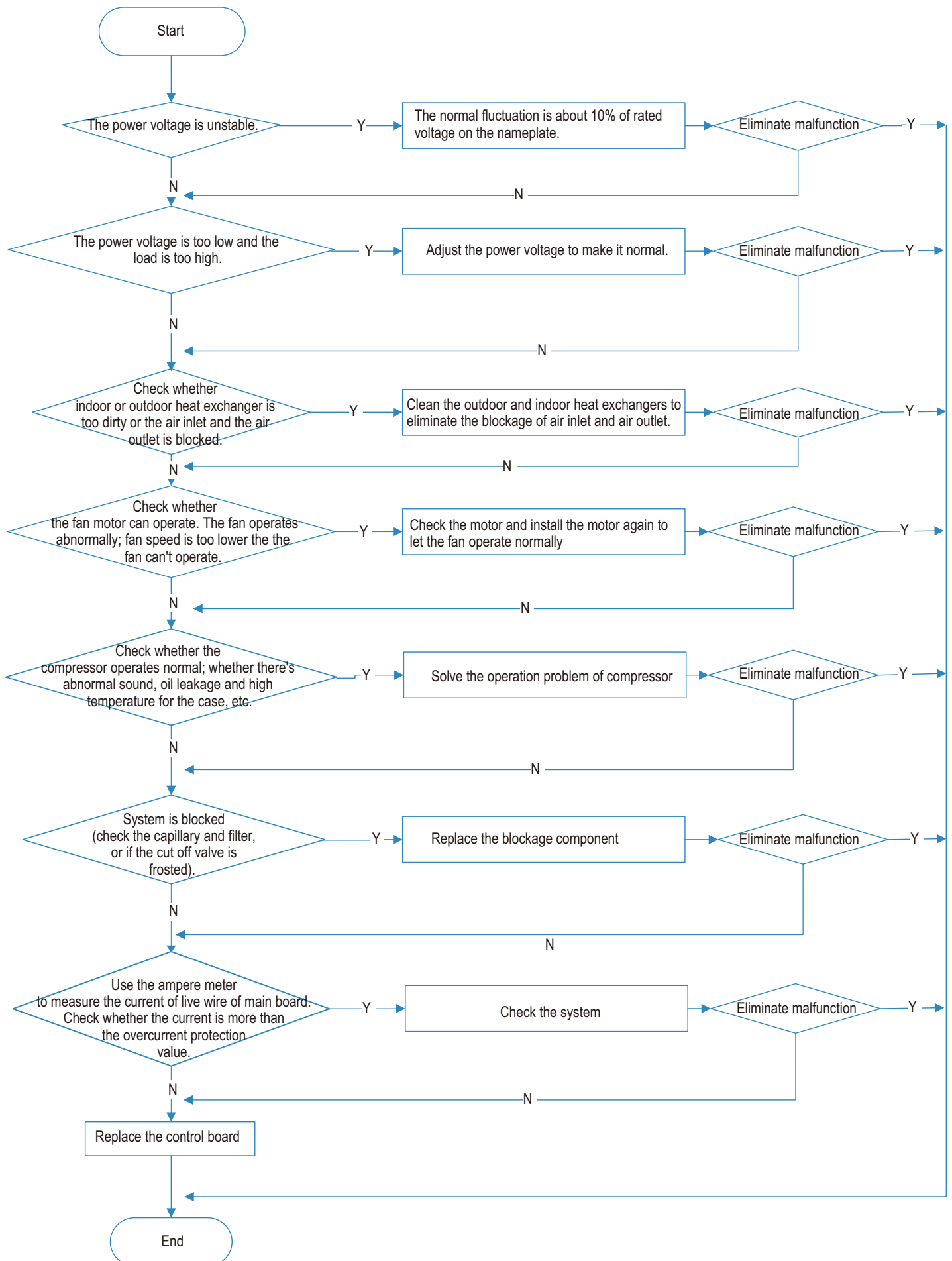

## 9.3 Troubleshooting for Normal Malfunction

### 1. Air Conditioner can't be Started Up

Possible Causes	Discriminating Method (Air conditioner Status)	Troubleshooting
No power supply, or poor connection for power plug	After energization, operation indicator isn't bright and the buzzer can't give out sound	Confirm whether it's due to power failure. If yes, wait for power recovery. If not, check power supply circuit and make sure the power plug is connected well.
Wrong wire connection between indoor unit and outdoor unit, or poor connection for wiring terminals	Under normal power supply circumstances, operation indicator isn't bright after energization	Check the circuit according to circuit diagram and connect wires correctly. Make sure all wiring terminals are connected firmly
Electric leakage for air conditioner	After energization, room circuit breaker trips off at once	Make sure the air conditioner is grounded reliably Make sure wires of air conditioner is connected correctly Check the wiring inside air conditioner. Check whether the insulation layer of power cord is damaged; if yes, place the power cord.
Model selection for air switch is improper	After energization, air switch trips off	Select proper air switch
Malfunction of remote controller	After energization, operation indicator is bright, while no display on remote controller or buttons have no action.	Replace batteries for remote controller Repair or replace remote controller

### 2. Poor Cooling (Heating) for Air Conditioner

Possible Causes	Discriminating Method (Air conditioner Status)	Troubleshooting
Set temperature is improper	Observe the set temperature on remote controller	Adjust the set temperature
Rotation speed of the IDU fan motor is set too low	Small wind blow	Set the fan speed at high or medium
Filter of indoor unit is blocked	Check the filter to see its blocked	Clean the filter
Installation position for indoor unit and outdoor unit is improper	Check whether the installation position is proper according to installation requirement for air conditioner	Adjust the installation position, and install the rainproof and sunproof for outdoor unit
Refrigerant is leaking	Discharged air temperature during cooling is higher than normal discharged wind temperature; Discharged air temperature during heating is lower than normal discharged wind temperature; Units pressure is much lower than regulated range	Find out the leakage causes and deal with it. Add refrigerant.
Malfunction of 4-way valve	Blow cold wind during heating	Replace the 4-way valve
Malfunction of capillary	Discharged air temperature during cooling is higher than normal discharged wind temperature; Discharged air temperature during heating is lower than normal discharged wind temperature; Unit pressure is much lower than regulated range. If refrigerant isn't leaking, part of capillary is blocked	Replace the capillary
Flow volume of valve is insufficient	The pressure of valves is much lower than that stated in the specification	Open the valve completely
Malfunction of horizontal louver	Horizontal louver can't swing	Refer to point 3 of maintenance method for details
Malfunction of the IDU fan motor	The IDU fan motor can't operate	Refer to troubleshooting for H6 for maintenance method in details
Malfunction of the ODU fan motor	The ODU fan motor can't operate	Refer to point 4 of maintenance method for details
Malfunction of compressor	Compressor can't operate	Refer to point 5 of maintenance method for details

### 3. Horizontal Louver can't Swing

Possible Causes	Discriminating Method (Air conditioner Status)	Troubleshooting
Wrong wire connection, or poor connection	Check the wiring status according to circuit diagram	Connect wires according to wiring diagram to make sure all wiring terminals are connected firmly
Stepping motor is damaged	Stepping motor can't operate	Repair or replace stepping motor
Main board is damaged	Others are all normal, while horizontal louver can't operate	Replace the main board with the same model

#### 4. ODU Fan Motor can't Operate

Possible causes	Discriminating method (air conditioner status)	Troubleshooting
Wrong wire connection, or poor connection	Check the wiring status according to circuit diagram	Connect wires according to wiring diagram to make sure all wiring terminals are connected firmly
Capacity of the ODU fan motor is damaged	Measure the capacity of fan capacitor with an universal meter and find that the capacity is out of the deviation range indicated on the nameplate of fan capacitor.	Replace the capacity of fan
Power voltage is a little low or high	Use universal meter to measure the power supply voltage. The voltage is a little high or low	Suggest to equip with voltage regulator
Motor of outdoor unit is damaged	When unit is on, cooling/heating performance is bad and ODU compressor generates a lot of noise and heat.	Change compressor oil and refrigerant. If no better, replace the compressor with a new one

#### 5. Compressor can't Operate

Possible causes	Discriminating method (air conditioner status)	Troubleshooting
Wrong wire connection, or poor connection	Check the wiring status according to circuit diagram	Connect wires according to wiring diagram to make sure all wiring terminals are connected firmly
Capacity of compressor is damaged	Measure the capacity of fan capacitor with an universal meter and find that the capacity is out of the deviation range indicated on the nameplate of fan capacitor.	Replace the compressor capacitor
Power voltage is a little low or high	Use universal meter to measure the power supply voltage. The voltage is a little high or low	Suggest to equip with voltage regulator
Coil of compressor is burnt out	Use universal meter to measure the resistance between compressor terminals and it's 0	Repair or replace compressor
Cylinder of compressor is blocked	Compressor can't operate	Repair or replace compressor

#### 6. Air Conditioner is Leaking

Possible causes	Discriminating method (air conditioner status)	Troubleshooting
Drain pipe is blocked	Water leaking from indoor unit	Eliminate the foreign objects inside the drain pipe
Drain pipe is broken	Water leaking from drain pipe	Replace drain pipe
Wrapping is not tight	Water leaking from the pipe connection place of indoor unit	Wrap it again and bundle it tightly

#### 7. Abnormal Sound and Vibration

Possible causes	Discriminating method (air conditioner status)	Troubleshooting
When turn on or turn off the unit, the panel and other parts will expand and theres abnormal sound	Theres the sound of "PAPA"	Normal phenomenon. Abnormal sound will disappear after a few minutes.
When turn on or turn off the unit, theres abnormal sound due to flow of refrigerant inside air conditioner	Water-running sound can be heard	Normal phenomenon. Abnormal sound will disappear after a few minutes.
Foreign objects inside the indoor unit or therere parts touching together inside the indoor unit	Theres abnormal sound fro indoor unit	Remove foreign objects. Adjust all parts position of indoor unit, tighten screws and stick damping plaster between connected parts
Foreign objects inside the outdoor unit or therere parts touching together inside the outdoor unit	Theres abnormal sound fro outdoor unit	Remove foreign objects. Adjust all parts position of outdoor unit, tighten screws and stick damping plaster between connected parts
Short circuit inside the magnetic coil	During heating, the way valve has abnormal electromagnetic sound	Replace magnetic coil
Abnormal shake of compressor	Outdoor unit gives out abnormal sound	Adjust the support foot mat of compressor, tighten the bolts
Abnormal sound inside the compressor	Abnormal sound inside the compressor	If add too much refrigerant during maintenance, please reduce refrigerant properly. Replace compressor for other circumstances.

# 10. Exploded View and Parts List

## 10.1 Indoor Unit

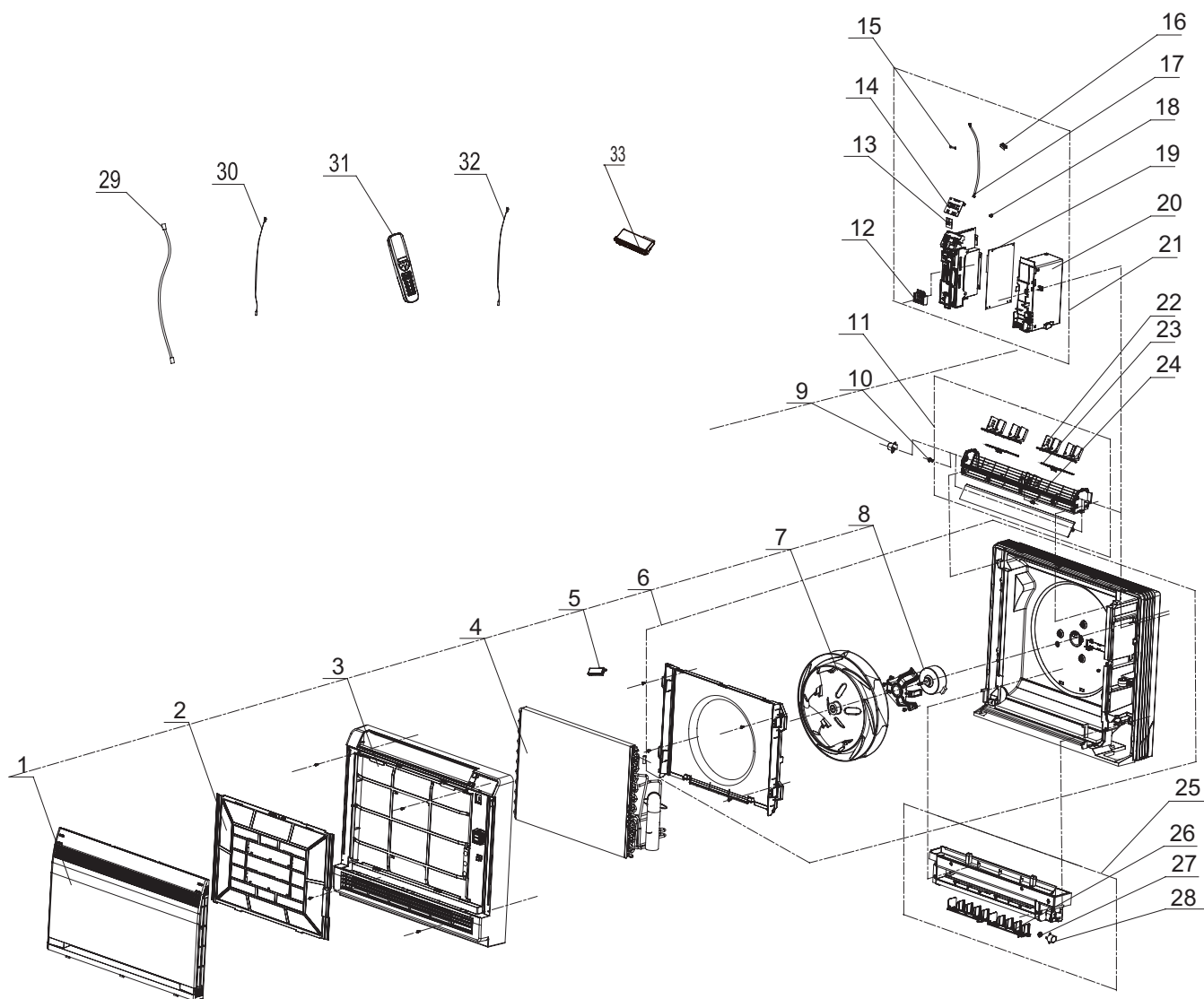

The component picture is only for reference; please refer to the actual product.

NO.	Description
1	Front Panel Assy
2	Filter Sub-Assy
3	Front Case Assy
4	Evaporator Assy
5	Cold Plasma Generator
6	Rear Case Assy
7	Centrifugal Fan
8	Fan Motor
9	Stepping Motor
10	Crank
11	Swing Assy
12	Terminal Board
13	Switch Board
14	Display Board
15	Fuse
16	Radiator
17	Signal Wire

NO.	Description
18	Jumper
19	Main Board
20	Electric Box
21	Electric Box Assy
22	Air Louver (upper)
23	Swing Lever
24	Shaft of Guide Louver
25	Water Tray Assy
26	Air Louver (lower)
27	Axis (lower step motor)
28	Stepping Motor
29	Connecting Cable
30	Temperature Sensor
31	Remote Controller
32	Temperature Sensor
33	Detecting Plate

Some models may not contain some parts, please refer to the actual product.

## 10.2 Outdoor Unit

AZI-FO25VE/O

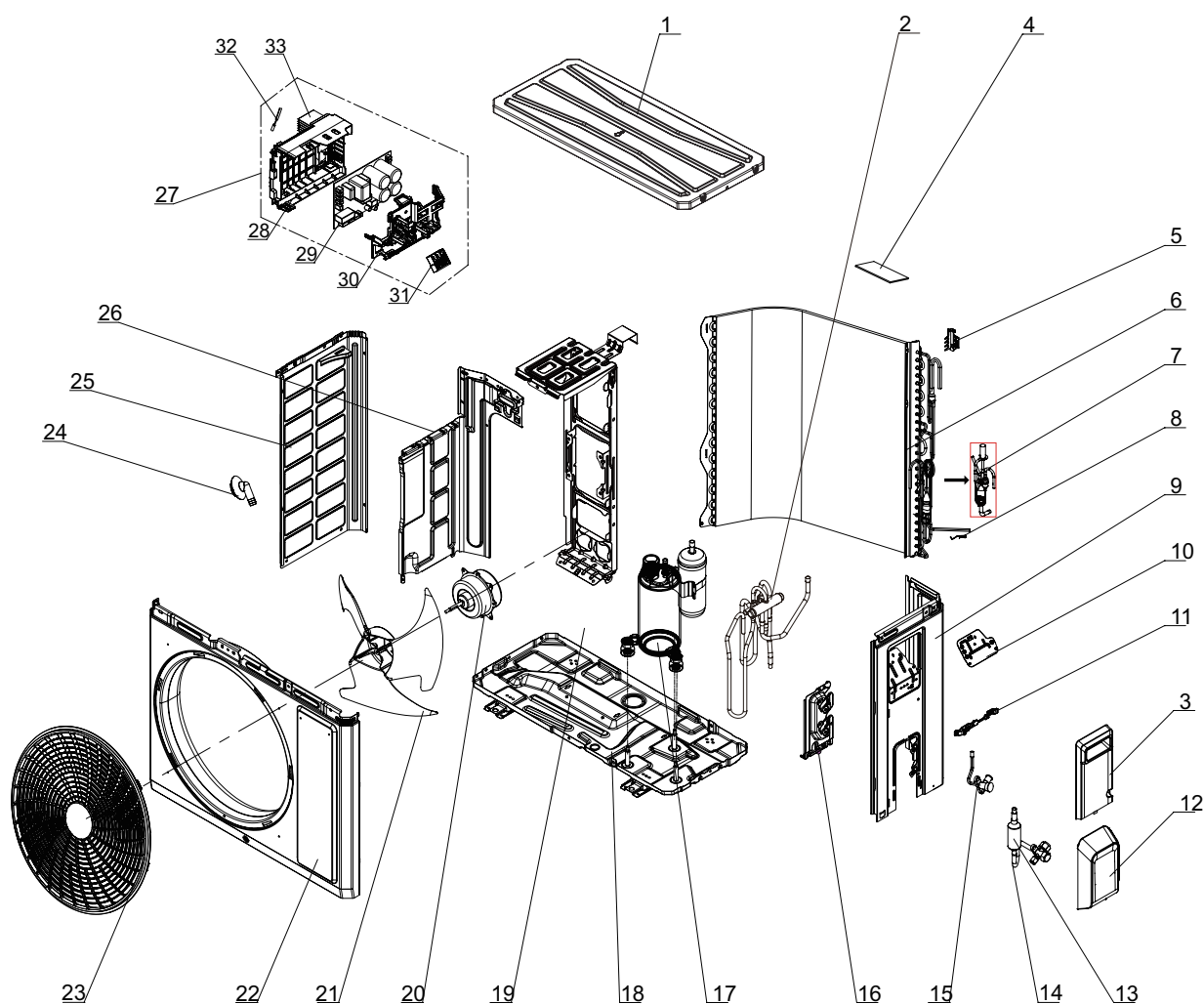

The component picture is only for reference; please refer to the actual product.

NO.	Description
1	Coping
2	4-Way Valve Assy
3	Handle (Right)
4	Sponge(Condenser)
5	Temperature Sensor Support
6	Condenser Assy
7	Electric Expansion Valve Sub-Assy
8	Sensor Insert
9	Right Side Plate
10	Earthing Plate Sub-Assy
11	Wire Clamp
12	Valve Cover

NO.	Description
13	Silencer
14	Cut off Valve Sub-Assy
15	Strainer
16	Valve Support
17	Compressor and Fittings
18	Chassis Sub-assy
19	Motor Support
20	Fan Motor
21	Axial Flow Fan
22	Cabinet
23	Front Grill
24	Drainage Joint(ODU)

NO.	Description
25	Left Side Plate
26	Clapboard
27	Electric Box Assy
28	Electric Box
29	Main Board
30	Electric Box Cover
31	Terminal Board
32	Temperature Sensor
33	Radiator

Some models may not contain some parts, please refer to the actual product.



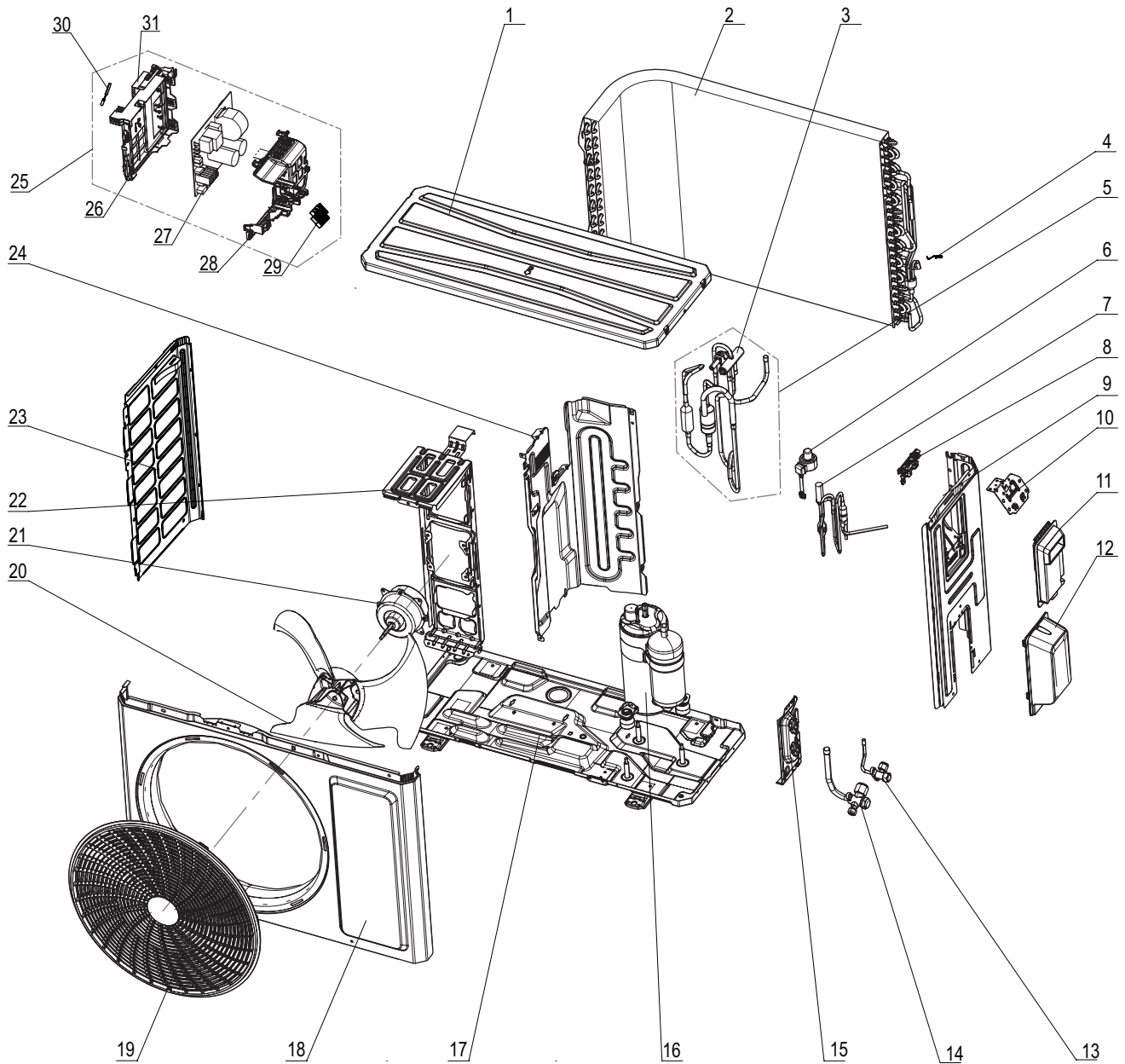

The component picture is only for reference; please refer to the actual product.

NO.	Description
1	Top Cover Assy Grill
2	Condenser Assy
3	4-Way Valve
4	Sensor Insert
5	4-Way Valve Assy
6	Electric Expansion Valve Fitting
7	Electric Expansion Valve Sub-Assy
8	Wire Clamp
9	Right Side Plate
10	Earthing Plate Sub-Assy

NO.	Description
11	Handle
12	Valve Cover
13	Cut-off valve 1/4(N)
14	Cut-off valve 3/8(N)
15	Valve Support
16	Compressor and Fittings
17	Chassis Sub-assy
18	Front Panel Assy
19	Front Grill
20	Axial Flow Fan

NO.	Description
21	Brushless DC Motor
22	Motor Support
23	Left Side Plate
24	Clapboard
25	Electric Box Assy
26	Electric Box
27	Main Board
28	Electric Box Cover
29	Terminal Board
30	Temperature Sensor
31	Radiator

Some models may not contain some parts, please refer to the actual product.

AZI-FO50VE/O

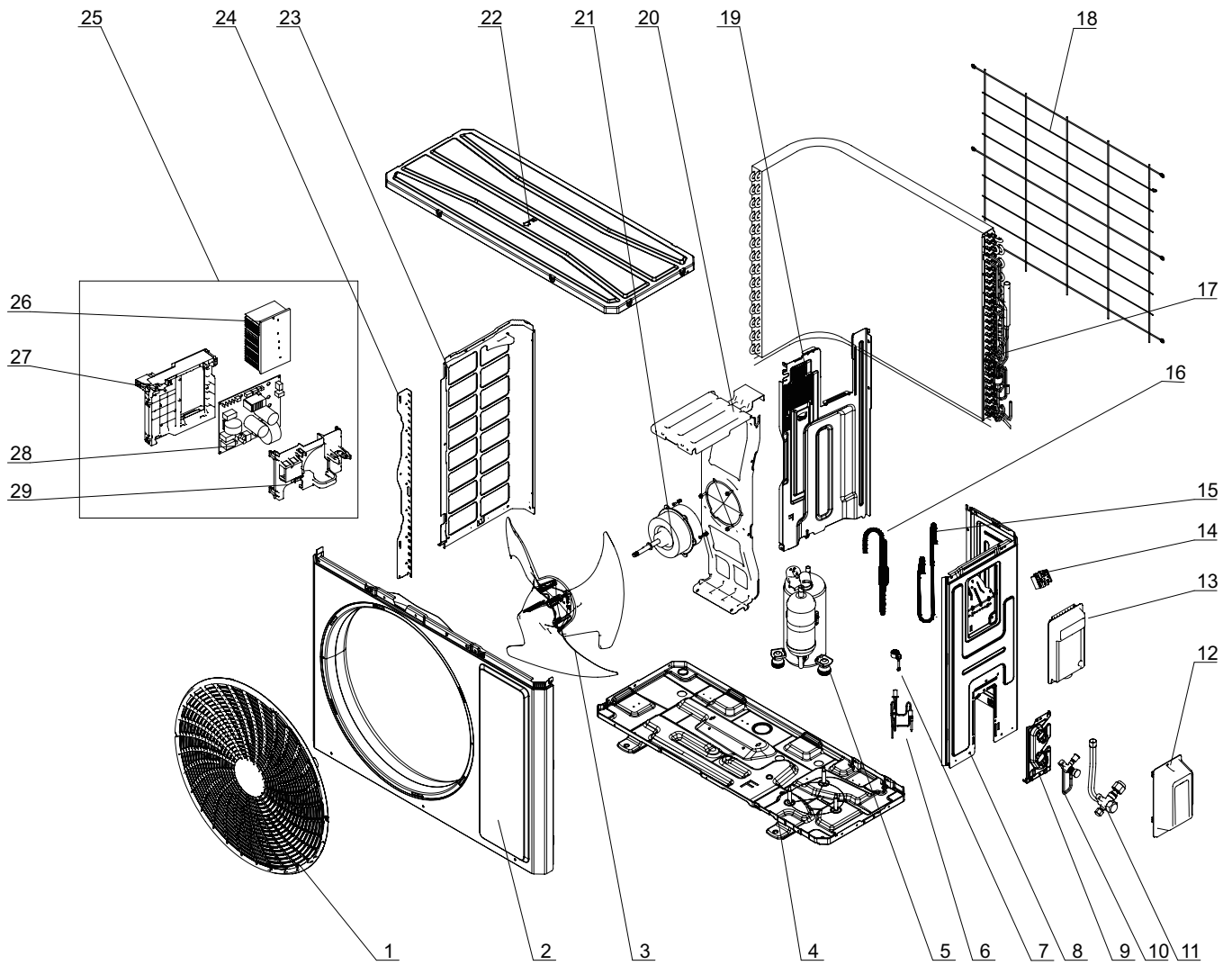

The component picture is only for reference; please refer to the actual product.

NO.	Description
1	Front Grill
2	Front Panel
3	Axial Flow Fan
4	Chassis Sub-assy
5	Compressor and Fittings
6	Electronic Expansion Valve
7	Electric Expand Valve Fitting
8	Right Side Plate
9	Valve Support
10	Cut-off valve

NO.	Description
11	Cut-off valve
12	Valve Cover
13	Handle
14	Terminal Board
15	Discharge Tube
16	Inhalation Tube
17	Condenser Assy
18	Rear Grill
19	Clapboard Assy
20	Motor Support

NO.	Description
21	Brushless DC Motor
22	Top Cover Assy
23	Left Side Plate
24	Condenser Left Border Plate
25	Electric Box Assy
26	Radiator
27	Electric Box
28	Main Board
29	Electric Box Cover

Some models may not contain some parts, please refer to the actual product.

# 11. Removal Procedure

## 11.1 Removal Procedure of Indoor Unit

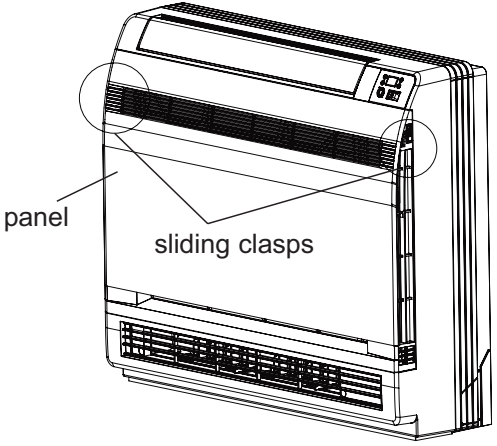
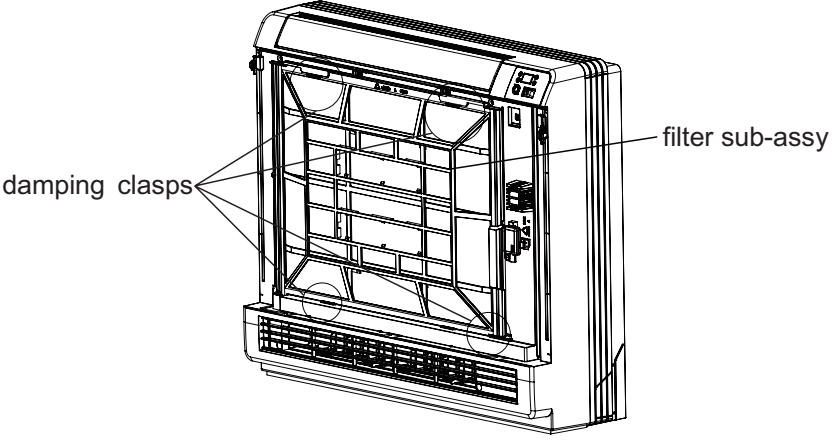
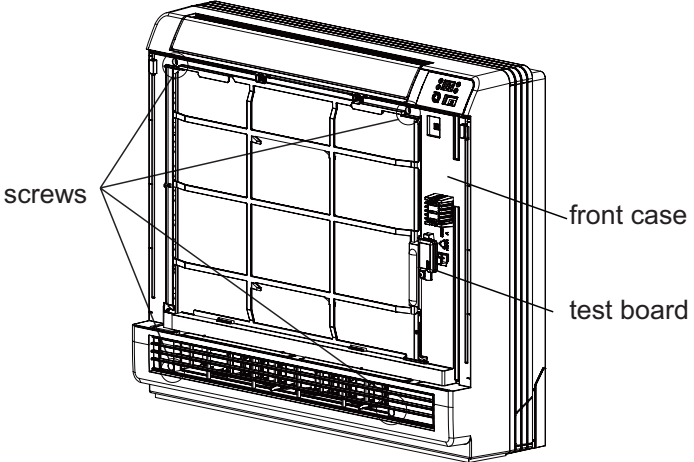

Caution: discharge the refrigerant completely before removal.

Step	Procedure
<b>1. Remove panel</b>	<p>Pull sliding clasps at both sides of panel, pull out the panel outwards and then move the panel upwards to remove it.</p> 
<b>2. Remove filter sub-assy</b>	<p>Pull the damping clasps at upper/lower side of filter sub-assy, and then move the filter sub-assy outwards to remove it.</p> 
<b>3. Remove test board and front case</b>	<p>Remove one screws fixing the test board, and then pull the test board outwards to remove it. Remove 4 screws fixing the front case, and then pull the front case outwards to remove it.</p> 

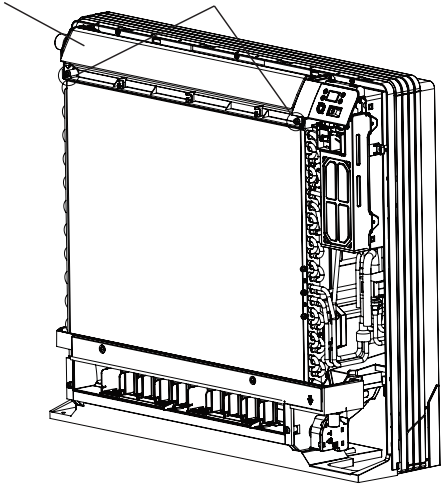
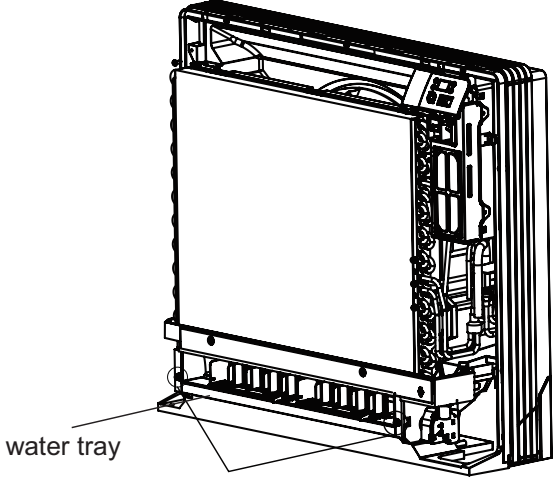
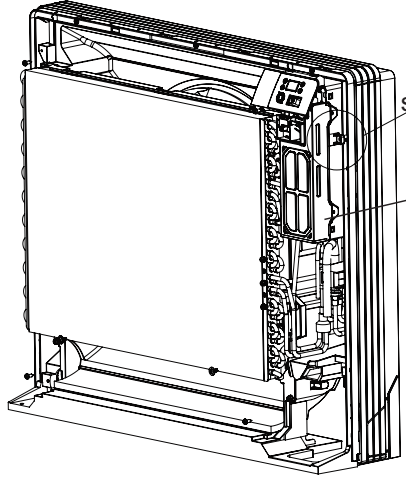
Step	Procedure	
<p><b>4.Remove swing parts</b></p>	<p>Remove 2 screws fixing the swing parts, and then pull the swing parts outwards to remove it.</p>	<p>swing parts</p> <p>screw</p> 
<p><b>5. Remove water tray</b></p>	<p>Remove 2 screws fixing water tray, and then pull the water tray outwards to remove it.</p>	<p>water tray</p> <p>screws</p> 
<p><b>6. Remove electric box</b></p>	<p>Remove one screw fixing the electric box, and then pull the electric box outwards to remove it.</p>	<p>screws</p> <p>electric box</p> 

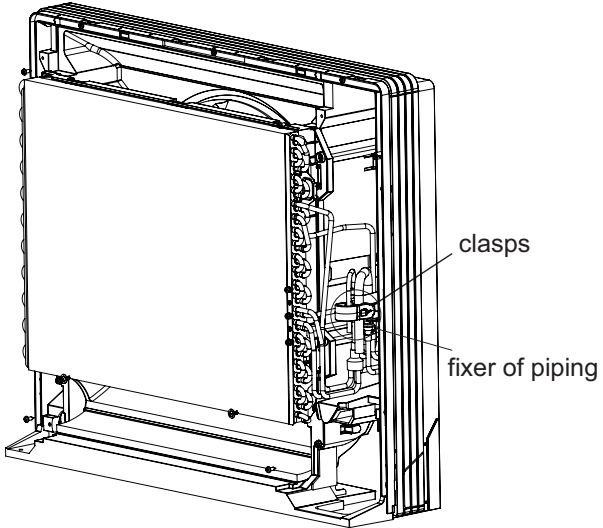
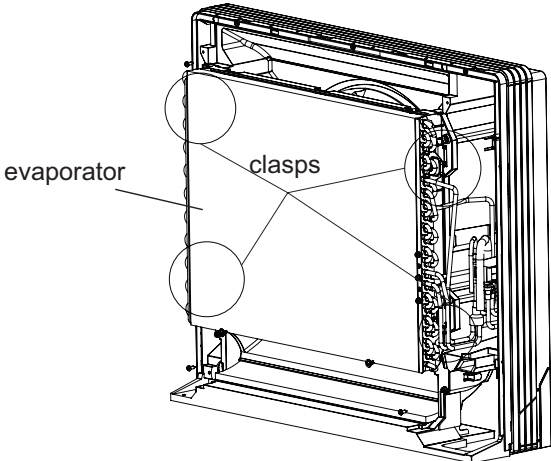
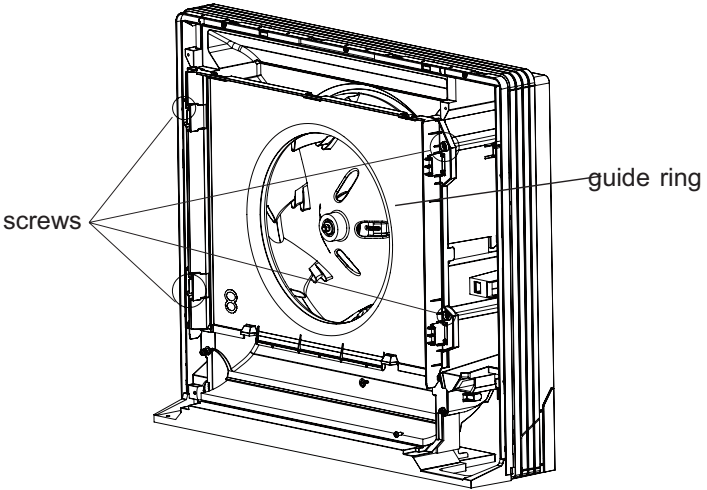
Step	Procedure
<p data-bbox="99 235 420 270"><b>7. Remove fixer of piping</b></p> <p data-bbox="180 515 613 609">Pry out the clasps connecting fixer of piping and bottom case, and then pull the fixer of piping outwards to remove it.</p>	
<p data-bbox="99 853 383 888"><b>8. Remove evaporator</b></p> <p data-bbox="180 1133 623 1227">Pry out the clasps connecting evaporator and bottom case, and then pull the evaporator outwards to remove it.</p>	
<p data-bbox="99 1472 373 1506"><b>9. Remove guide ring</b></p> <p data-bbox="180 1751 607 1845">Remove 4 screws fixing guide ring, and then pull the guide ring outwards to remove it.</p>	

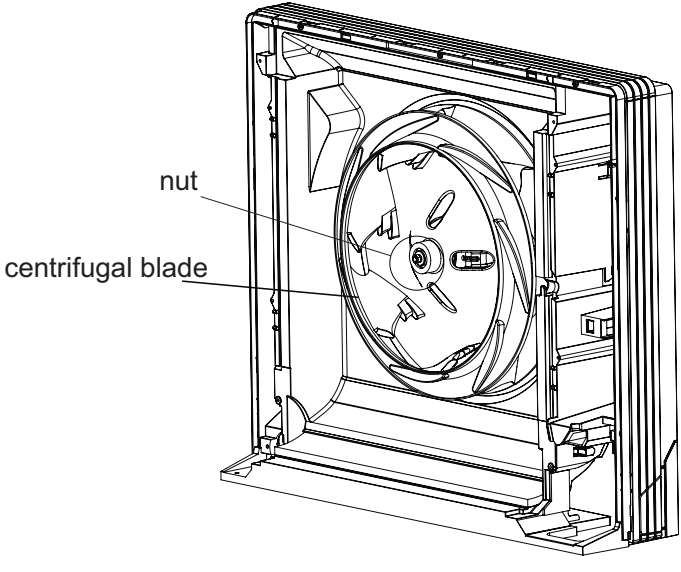
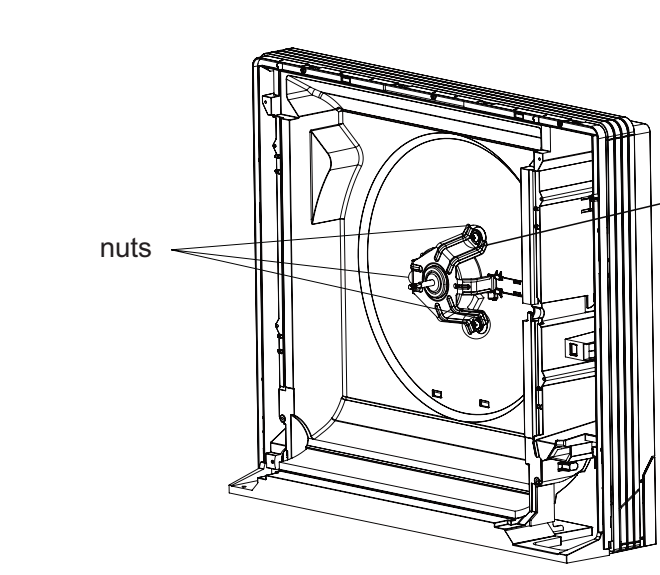
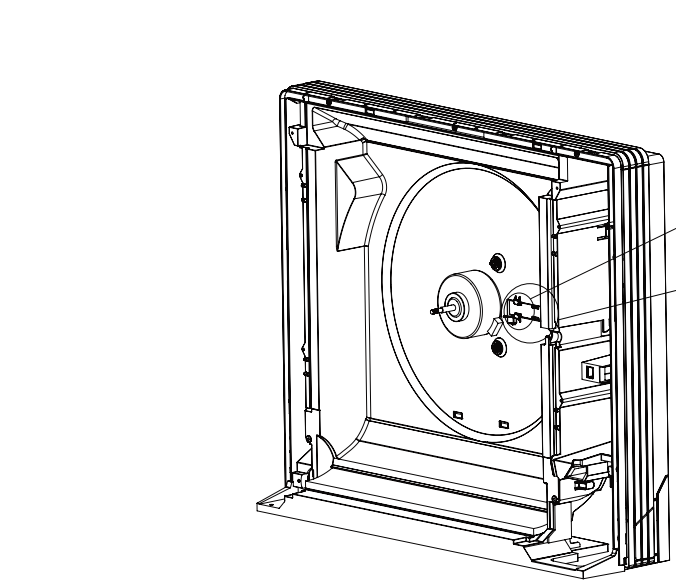
Step	Procedure
<p><b>10. Remove centrifugal blade</b></p> <p>Remove one nut fixing the centrifugal blade, and then pull the centrifugal blade outwards to remove it.</p>	 <p>The diagram shows a centrifugal blade assembly mounted on a frame. A single nut is shown being removed from the blade's mounting point. Labels 'nut' and 'centrifugal blade' point to the respective parts.</p>
<p><b>11. Remove fixing bracket of motor</b></p> <p>Remove 3 nuts on fixing bracket of motor, and then pull the fixing bracket of motor outwards to remove it.</p>	 <p>The diagram shows a motor fixing bracket assembly mounted on a frame. Three nuts are shown being removed from the bracket's mounting points. Labels 'nuts' and 'fixing bracket of motor' point to the respective parts.</p>
<p><b>12. Remove press plate of motor wire</b></p> <p>Loosen clasps between press plate of motor wire and bottom case, and then pull the press plate of motor wire outwards to remove it.</p>	 <p>The diagram shows a motor wire press plate assembly mounted on a frame. Two clasps are shown being loosened from the press plate. Labels 'clasps' and 'press plate of motor wire' point to the respective parts.</p>



## 11.2 Removal Procedure of Outdoor Unit

09K

(The front grill appearance is for reference only)



**Caution: discharge the refrigerant completely before removal.**

Step	Procedure
<b>1. Before disassembly</b>	
<b>2. Remove big handle and valve cover</b>	<p data-bbox="191 1159 789 1225">Remove the screws fixing big handle, valve cover and then remove them.</p> 
<b>3. Remove top cover</b>	<p data-bbox="191 1760 789 1825">Remove the screws fixing top panel and then remove the top panel.</p> 

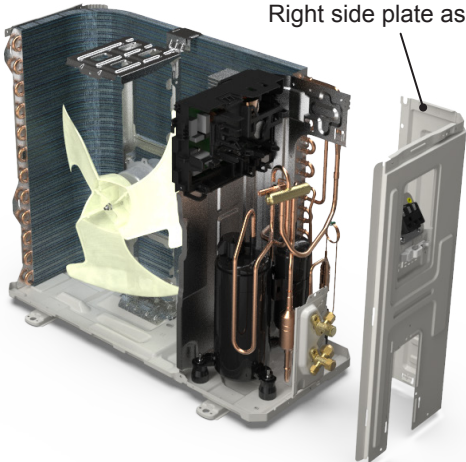
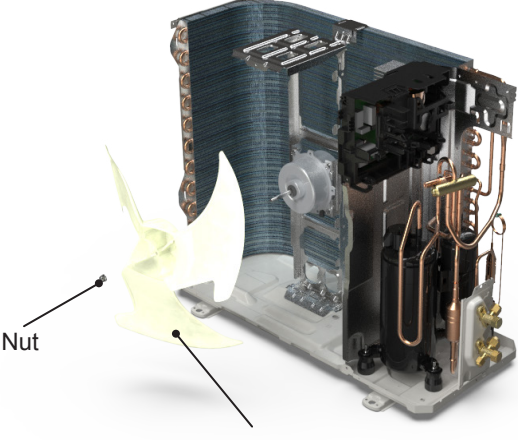
Step	Procedure
<p><b>4. Remove front panel assy</b></p>	<p>Remove connection screws connecting the front panel assy with the chassis and the motor support, and then remove the front panel assy.</p>  <p>Front panel assy</p>
<p><b>5. Remove right side plate assy</b></p>	<p>Rescrew the ground screws, remove the ground wires, loosen the screws fixing terminal board, remove the terminal board, rescrew the screws fixing the right plate, and remove the right side plate assy.</p>  <p>Right side plate assy</p>
<p><b>6. Remove axial flow fan</b></p>	<p>Remove the nut on the fan and then remove the axial flow fan.</p>  <p>Nut</p> <p>Axial flow fan</p>

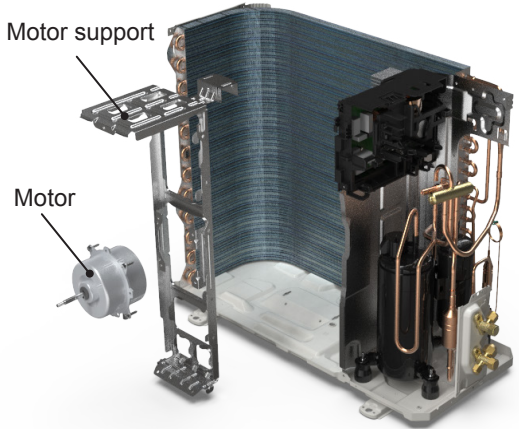
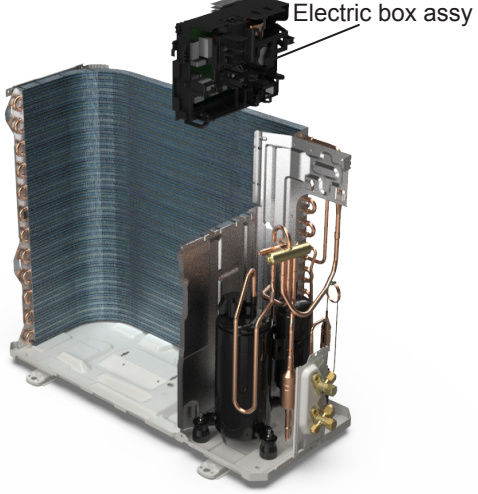
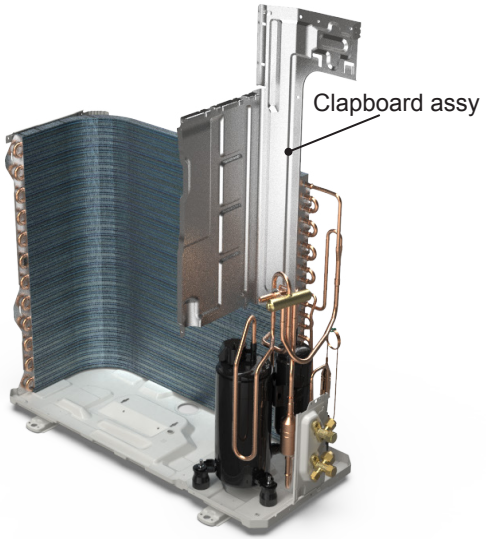

Step	Procedure
<p><b>7. Remove motor support and motor</b></p>	<p>Remove the screws fixing the motor support and lift the motor support to remove it. Remove the screws fixing the motor and then remove the motor.</p> 
<p><b>8. Remove electric box assy</b></p>	<p>Remove the terminals, lift up and rotate the electrical box assy to the right so that the snaps on the clapboard are removed and the electrical box assy are removed.</p> 
<p><b>9. Remove clapboard assy</b></p>	<p>Remove the screws fixing the clapboard assy and then remove the clapboard assy.</p> 

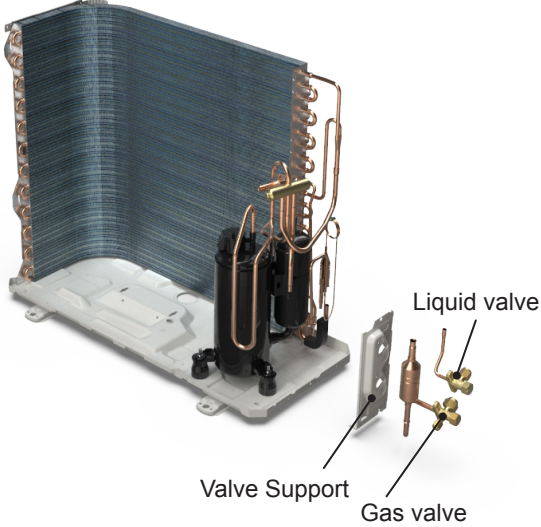
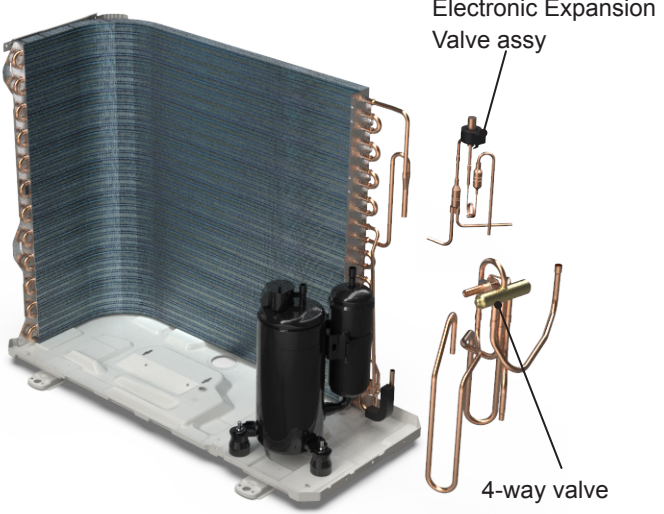
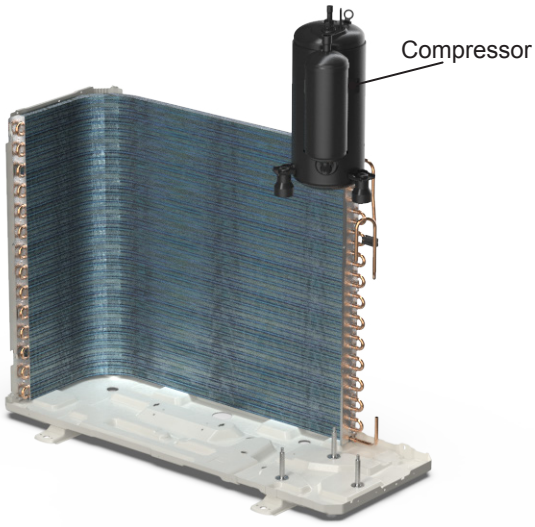
Step	Procedure
<p><b>10. Remove gas valve and liquid valve</b></p> <p>Remove the valve support block, remove the screws fixing the gas valve and the liquid valve, unsolder the welding joint connecting the gas valve and the liquid valve, remove them.</p> <p>Note: Discharge the refrigerant completely before unsoldering; when unsoldering, wrap the gas valve with a wet cloth completely to avoid damage to the valve caused by high temperature.</p>	
<p><b>11. Remove 4-way valve and Electronic Expansion Valve assy</b></p> <p>Unsolder the welding joints connecting Electronic Expansion Valve assy and then remove it.</p> <p>Unsolder the welding joints connecting the 4-way valve assy with capillary sub-assy, compressor and condenser; remove the 4-way valve. Cooling only unit removes Discharge Tube and Inhalation Tube.</p> <p>Note: Before unsoldering the welding joint, wrap the 4-way valve with a wet cloth completely to avoid damage to the valve caused by high temperature.</p>	
<p><b>12. Remove compressor</b></p> <p>Remove the 3 foot nuts on the compressor and then remove the compressor.</p>	



**Caution: discharge the refrigerant completely before removal.**

(The front grill appearance is for reference only)

Step	Procedure
<p><b>1. Before disassembly</b></p>	
<p><b>2. Remove big handle and valve cover</b></p>	<p>Remove the screws fixing big handle, valve cover and then remove them.</p> 
<p><b>3. Remove top cover</b></p>	<p>Remove the screws fixing top panel and then remove the top panel.</p> 

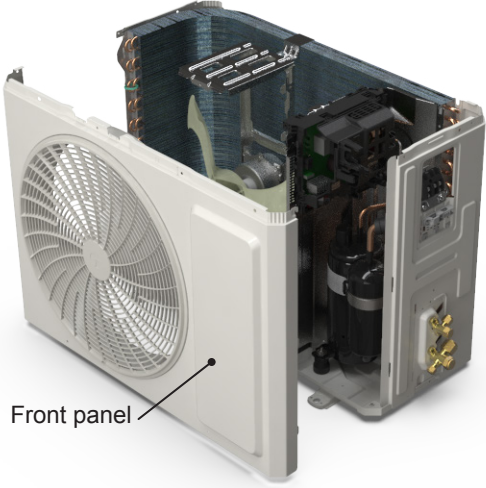
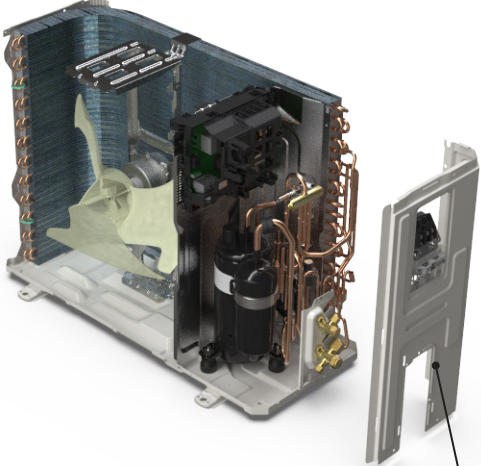
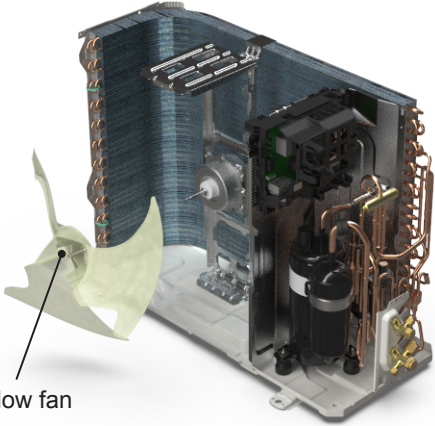
Step	Procedure
<p><b>4. Remove front panel assy</b></p>	<p>Remove connection screws connecting the front panel assy with the chassis and the motor support, and then remove the front panel assy.</p> 
<p><b>5. Remove right side plate assy</b></p>	<p>Rescrew the ground screws, remove the ground wires, loosen the screws fixing terminal board, remove the terminal board, rescrew the screws fixing the right plate, and remove the right side plate assy.</p> 
<p><b>6. Remove axial flow fan</b></p>	<p>Remove the nut on the fan and then remove the axial flow fan.</p> 

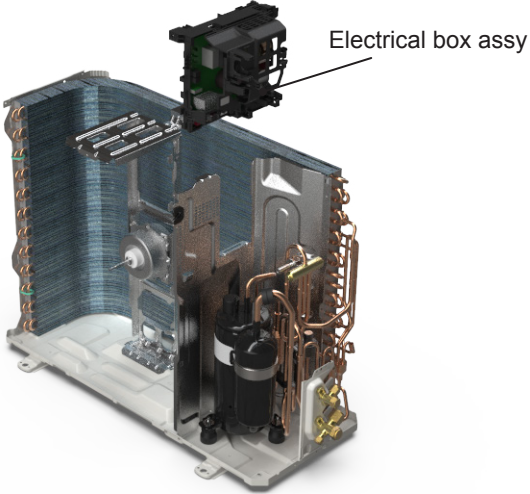
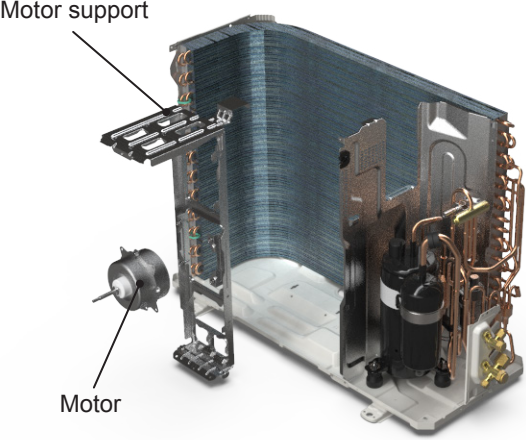
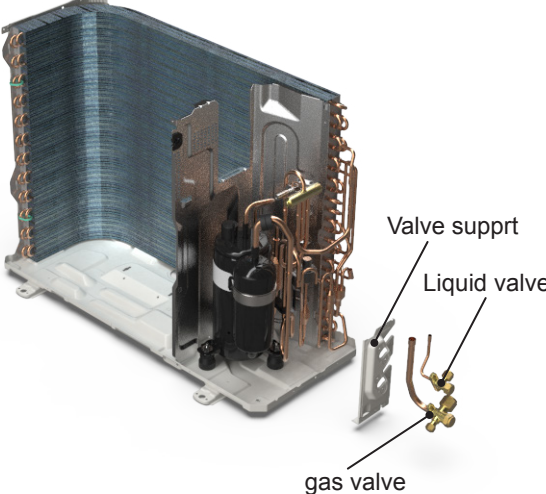
Step	Procedure
<p><b>7. Remove electric box assy</b></p>	<p>Remove the terminals, lift up and rotate the electrical box assy to the right so that the snaps on the clapboard are removed and the electrical box assy are removed.</p>  <p>Electrical box assy</p>
<p><b>8. Remove motor and motor support</b></p>	<p>Remove the screws fixing the motor and then remove the motor. Remove the screws fixing the motor support and lift the motor support to remove it.</p>  <p>Motor support</p> <p>Motor</p>
<p><b>9. Remove gas valve, liquid valve and valve support</b></p>	<p>Remove the valve support block, remove the screws fixing the gas valve and the liquid valve, unsolder the welding joint connecting the gas valve and the liquid valve, remove them. Note: Discharge the refrigerant completely before unsoldering; when unsoldering, wrap the gas valve with a wet cloth completely to avoid damage to the valve caused by high temperature. Remove the screws fixing valve support, then remove the valve support.</p>  <p>Valve support</p> <p>Liquid valve</p> <p>gas valve</p>

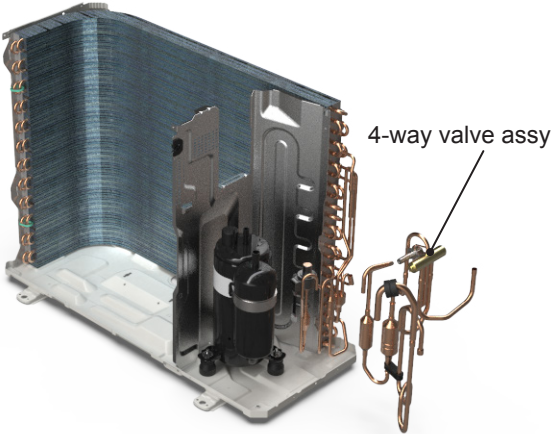
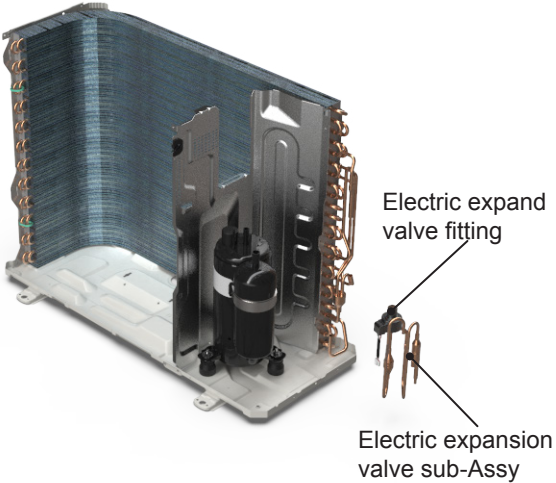
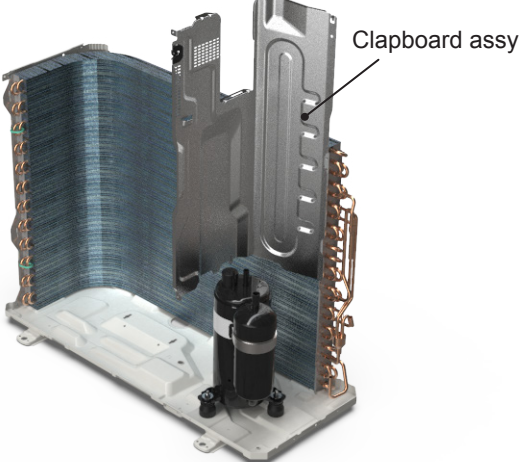
Step	Procedure
<p><b>10. Remove 4-way valve assy</b></p>	<p>Unsolder the welding joints connecting the 4-way valve assy, remove the 4-way valve.</p> <p>Note: Before unsoldering the welding joint, wrap the 4-way valve with a wet cloth completely to avoid damage to the valve caused by high temperature.</p> 
<p><b>11. Remove electric expansion valve sub-Assy</b></p>	<p>Unsolder the spot weld of electric expansion valve sub-Assy and condenser, and then remove the electric expansion valve sub-Assy.</p> <p>Note: When unsoldering the spot weld, wrap the electric expansion valve sub-Assy with wet cloth completely to avoid damaging the valve due to high temperature.</p> 
<p><b>12. Remove clapboard assy</b></p>	<p>Remove the screws fixing the clapboard assy and then remove the clapboard assy.</p> 

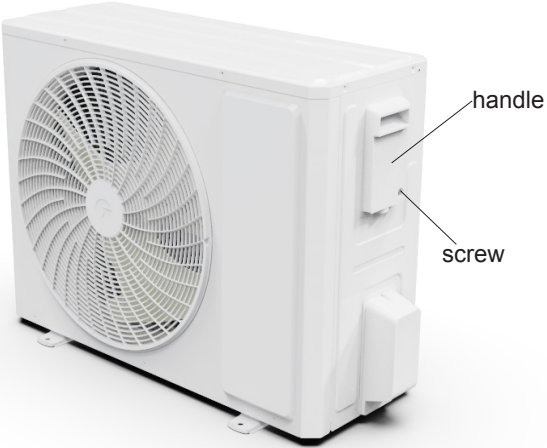
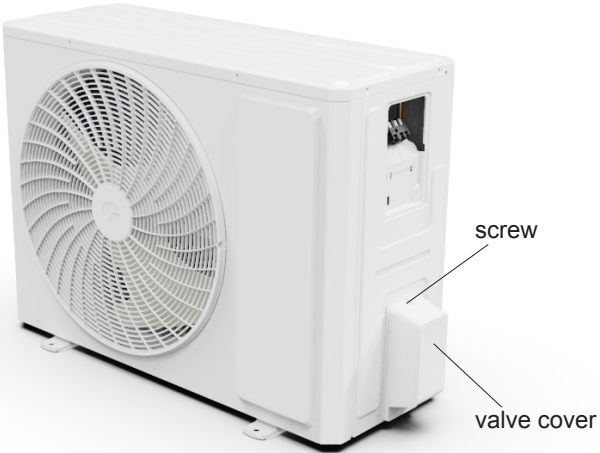
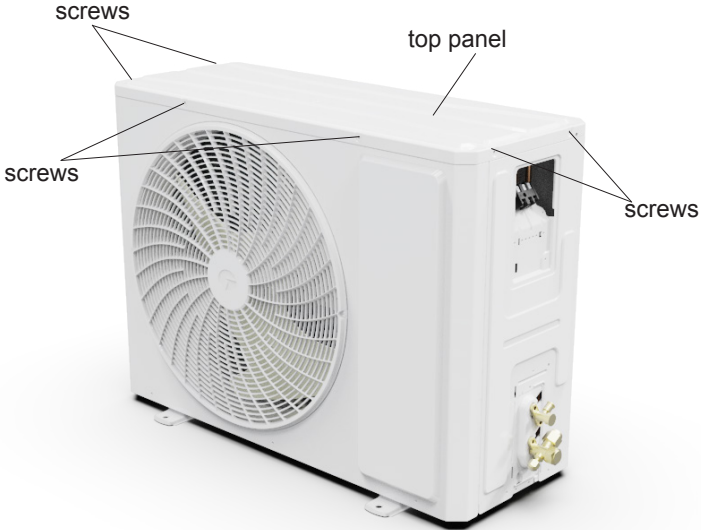

**Caution: discharge the refrigerant completely before removal.**

Step	Procedure
<p><b>1. Remove handle</b></p> <p>Remove the screw fixing the handle and then remove the handle.</p>	 <p>Diagram illustrating the removal of the handle. The handle is shown attached to the side of the outdoor unit, secured by a screw. Labels indicate the 'handle' and the 'screw'.</p>
<p><b>2. Remove valve cover</b></p> <p>Remove the screw fixing the valve cover and then remove the valve cover.</p>	 <p>Diagram illustrating the removal of the valve cover. The valve cover is shown attached to the side of the outdoor unit, secured by a screw. Labels indicate the 'screw' and the 'valve cover'.</p>
<p><b>3. Remove top panel</b></p> <p>Remove the screws fixing the top panel and then remove the top panel.</p>	 <p>Diagram illustrating the removal of the top panel. The top panel is shown attached to the top of the outdoor unit, secured by screws. Labels indicate the 'screws' and the 'top panel'.</p>

Step	Procedure
------	-----------

**4. Remove grille**

Remove the screws fixing the grille and then remove the panel grille.

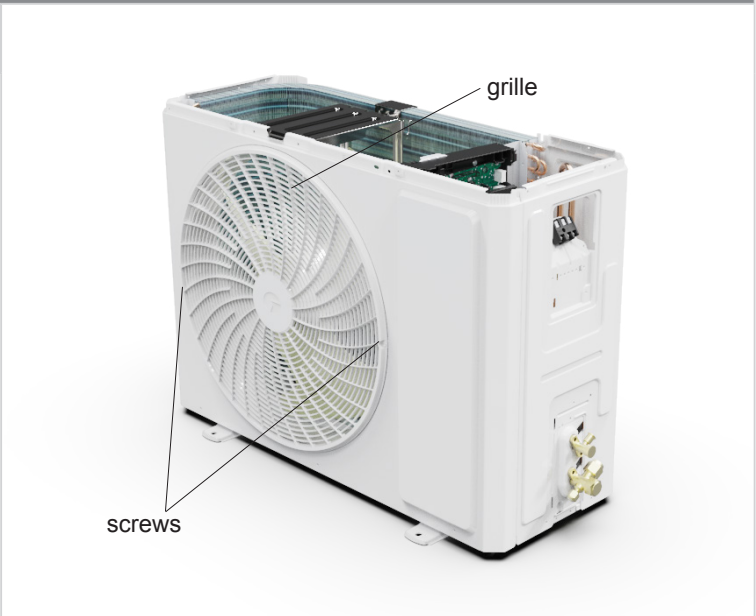

**5. Remove front panel**

Remove screws fixing the front panel and then remove the front panel.



**6. Remove right side plate**

Remove screws fixing connecting the front panel with the chassis and the motor support, and then remove the right side plate.



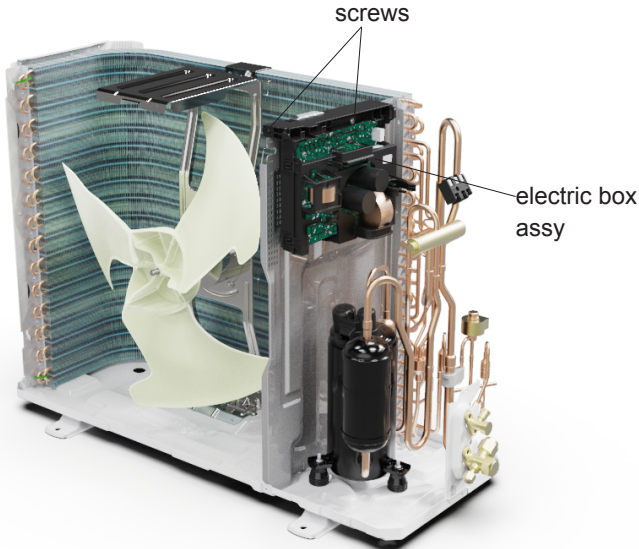
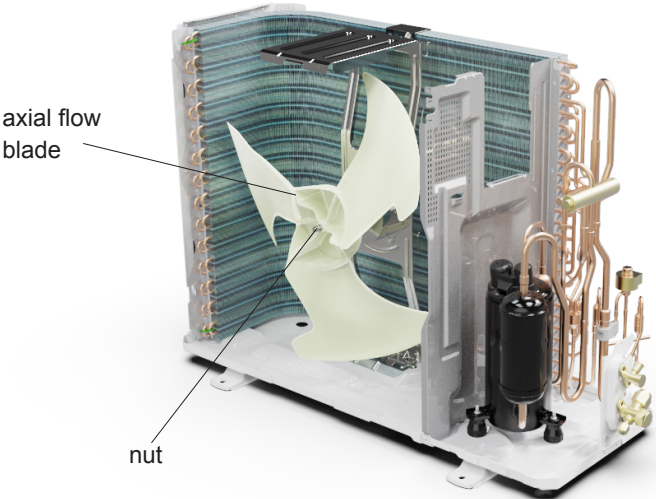
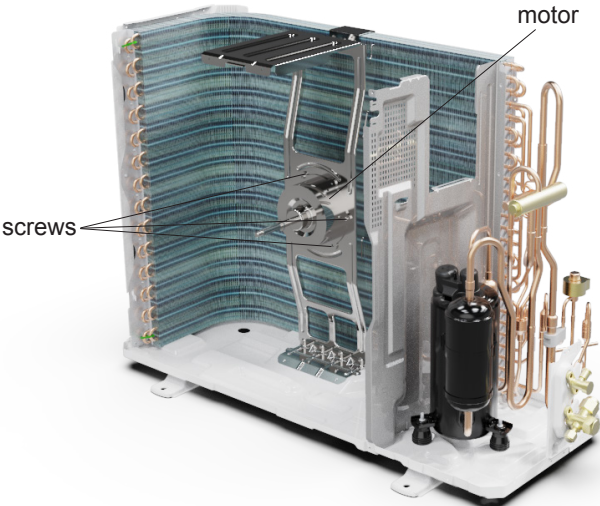

Step	Procedure
<p><b>7. Remove electric box assy</b></p>	<p>Remove the screws fixing the electricbox; loosen the wire bundle; pull out the wiring terminals and then pull electric box upwards to remove it.</p> 
<p><b>8. Remove axial flow blade</b></p>	<p>Remove nut fixing the blade and then remove the blade.</p> 
<p><b>9. Remove motor</b></p>	<p>Remove screws fixing the motor and then remove the motor.</p> 

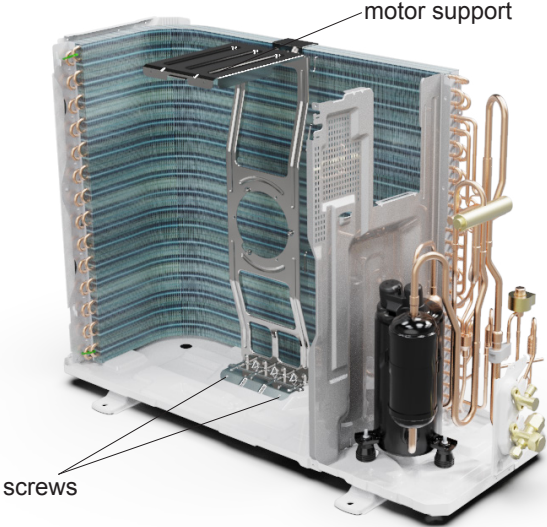
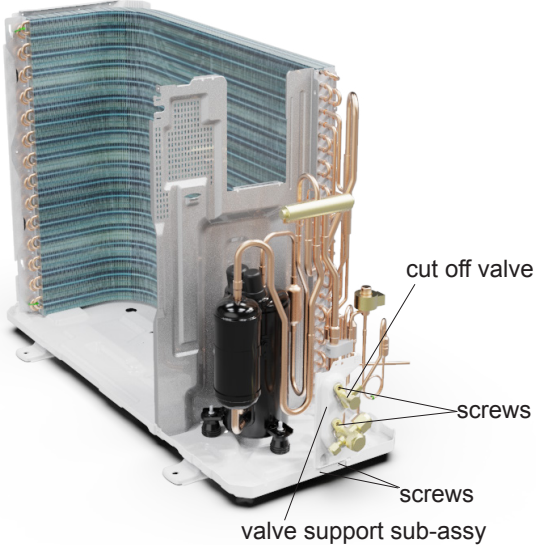
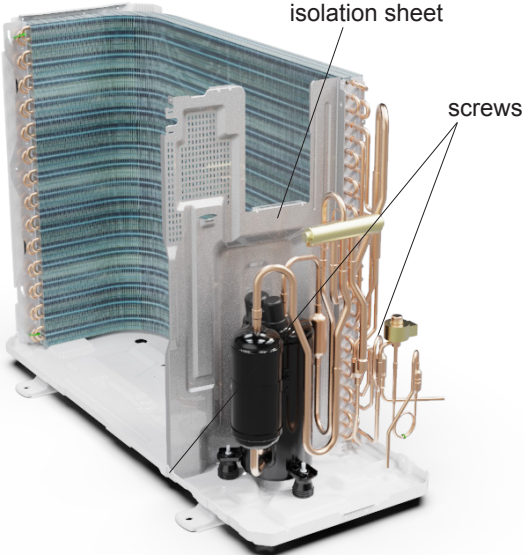
Step	Procedure
<p><b>10. Remove motor support</b></p>	<p>Remove screws fixing the motor support and then remove the motor support.</p> 
<p><b>11. Remove cut off valve and valve support sub-assy</b></p>	<p>Remove screws fixing the cut off valve and then remove the cut off valve;  Remove screws fixing the valve support subassy and then remove the valve support subassy.  Note:  When pulling out the wiring terminal, pay attention to loose the clasp and don't pull it so hard.</p> 
<p><b>12. Remove isolation sheet</b></p>	<p>Remove the screws fixing the isolation sheet and then remove the isolation sheet.</p> 

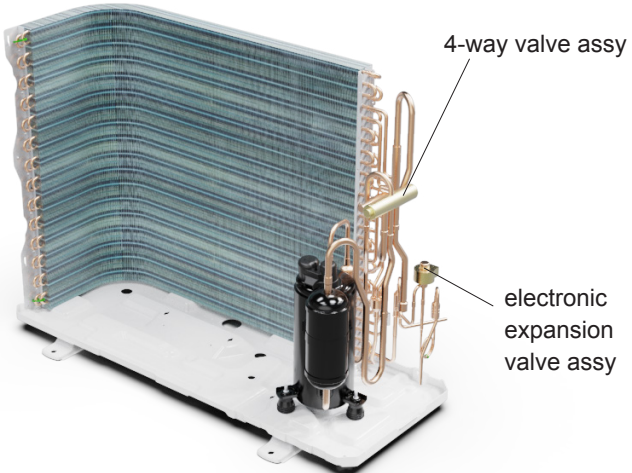
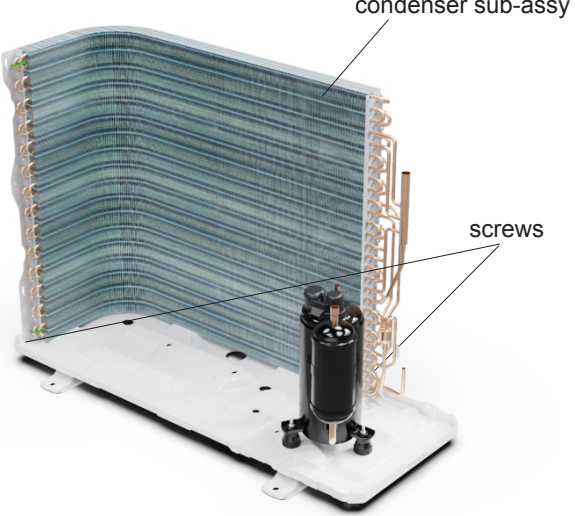
Step	Procedure
<p><b>13. Remove left side plate</b></p>	<p>Remove the screws fixing the left side plate and the chassis, and then remove the left side plate.</p> 
<p><b>14. Remove 4-way valve assy and electronic expansion valve assy</b></p>	<p>Unsolder the welding joints connecting electronic expansion valve assy the 4-way valve assy with capillary sub-assy, compressor and condenser; remove the electronic expansion valve assy and 4-way valve.</p> <p>Note: Before unsoldering the welding joint, wrap the 4-way valve with a wet cloth completely to avoid damage to the valve caused by high temperature.</p> 
<p><b>15. Remove condenser sub-assy</b></p>	<p>Remove the screws fixing the condenser and chassis, and then lift the condenser upwards to remove it.</p> 

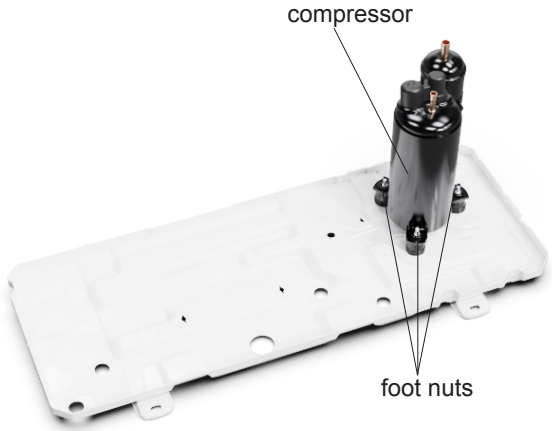
Step	Procedure
<b>16. Remove compressor</b>	<p data-bbox="191 585 787 650">Remove the 3 foot nuts on the compressor and then remove the compressor.</p> 

# Appendix:

## Appendix 1: Reference Sheet of Celsius and Fahrenheit

Conversion formula for Fahrenheit degree and Celsius degree:  $T_f = T_c \times 1.8 + 32$

### Set temperature

Fahrenheit display temperature (°F)	Fahrenheit (°F)	Celsius (°C)	Fahrenheit display temperature (°F)	Fahrenheit (°F)	Celsius (°C)	Fahrenheit display temperature (°F)	Fahrenheit (°F)	Celsius (°C)
61	60.8	16	69/70	69.8	21	78/79	78.8	26
62/63	62.6	17	71/72	71.6	22	80/81	80.6	27
64/65	64.4	18	73/74	73.4	23	82/83	82.4	28
66/67	66.2	19	75/76	75.2	24	84/85	84.2	29
68	68	20	77	77	25	86	86	30

### Ambient temperature

Fahrenheit display temperature (°F)	Fahrenheit (°F)	Celsius (°C)	Fahrenheit display temperature (°F)	Fahrenheit (°F)	Celsius (°C)	Fahrenheit display temperature (°F)	Fahrenheit (°F)	Celsius (°C)
32/33	32	0	55/56	55.4	13	79/80	78.8	26
34/35	33.8	1	57/58	57.2	14	81	80.6	27
36	35.6	2	59/60	59	15	82/83	82.4	28
37/38	37.4	3	61/62	60.8	16	84/85	84.2	29
39/40	39.2	4	63	62.6	17	86/87	86	30
41/42	41	5	64/65	64.4	18	88/89	87.8	31
43/44	42.8	6	66/67	66.2	19	90	89.6	32
45	44.6	7	68/69	68	20	91/92	91.4	33
46/47	46.4	8	70/71	69.8	21	93/94	93.2	34
48/49	48.2	9	72	71.6	22	95/96	95	35
50/51	50	10	73/74	73.4	23	97/98	96.8	36
52/53	51.8	11	75/76	75.2	24	99	98.6	37
54	53.6	12	77/78	77	25			

## Appendix 2: Configuration of Connection Pipe

- Standard length of connection pipe (More details please refer to the specifications.)
- Min length of connection pipe For the unit with standard connection pipe of 5m, there is no limitation for them in length of connection pipe. For the unit with standard connection pipe of 7.5m and 8m, the min length of connection pipe is 3m.
- Max. length of connection pipe and max. high difference. (More details please refer to the specifications.)
- The additional refrigerant oil and refrigerant charging required after prolonging connection pipe
  - After the length of connection pipe is prolonged for 10m at the basis of standard length, you should add 5ml of refrigerant oil for each additional 5m of connection pipe.
  - The calculation method of additional refrigerant charging amount (on the basis of liquid pipe):
  - Basing on the length of standard pipe, add refrigerant according to the requirement as shown in the table. The additional refrigerant charging amount per meter is different according to the diameter of liquid pipe. See the following sheet.
  - Additional refrigerant charging amount = prolonged length of liquid pipe X additional refrigerant charging amount per meter.

Additional refrigerant charging amount for R32

Piping size		Indoor unit throttle	Outdoor unit throttle	
Liquid pipe	Gas pipe	Cooling only, cooling and heating (g / m)	Cooling only(g/m)	Cooling and heating(g/m)
1/4"	3/8" or 1/2"	14	12	16
1/4" or 3/8"	5/8" or 3/4"	40	12	40
1/2"	3/4" or 7/8"	80	24	96
5/8"	1" or 1 1/4"	136	48	96
3/4"	/	200	200	200
7/8"	/	280	280	280

## Appendix 3: Pipe Expanding Method

### ⚠ Note:

Improper pipe expanding is the main cause of refrigerant leakage. Please expand the pipe according to the following steps:

#### A: Cut the pipe

- Confirm the pipe length according to the distance of indoor unit and outdoor unit.
- Cut the required pipe with pipe cutter.

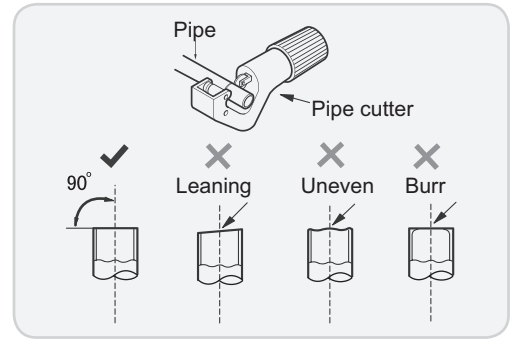

#### B: Remove the burrs

- Remove the burrs with shaper and prevent the burrs from getting into the pipe.

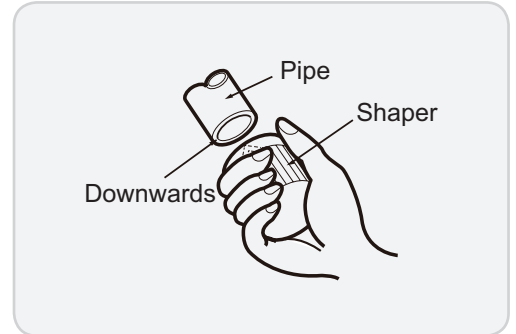

#### C: Put on suitable insulating pipe.

#### D: Put on the union nut

- Remove the union nut on the indoor connection pipe and outdoor valve; install the union nut on the pipe.

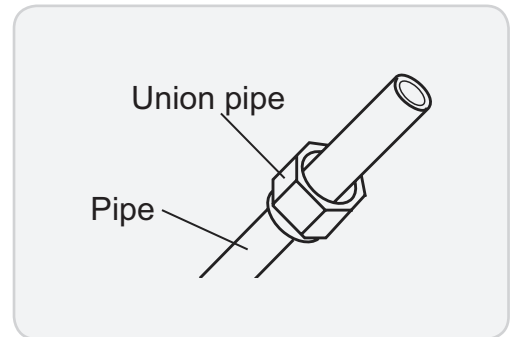

#### E: Expand the port

- Expand the port with expander.

### ⚠ Note:

- "A" is different according to the diameter, please refer to the sheet below:

Outer diameter(mm)	A(mm)	
	Max	Min
Φ6 - 6.35 (1/4")	1.3	0.7
Φ9.52 (3/8")	1.6	1.0
Φ12 - 12.70 (1/2")	1.8	1.0
Φ16 - 15.88 (5/8")	2.4	2.2

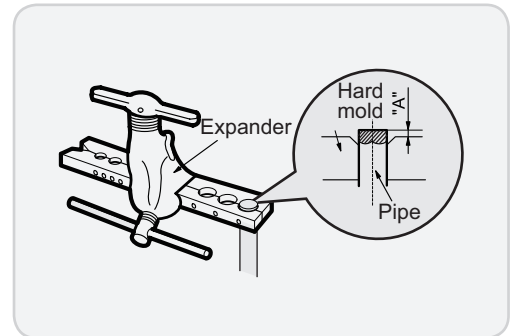

#### F: Inspection

- Check the quality of expanding port. If there is any blemish, expand the port again according to the steps above.

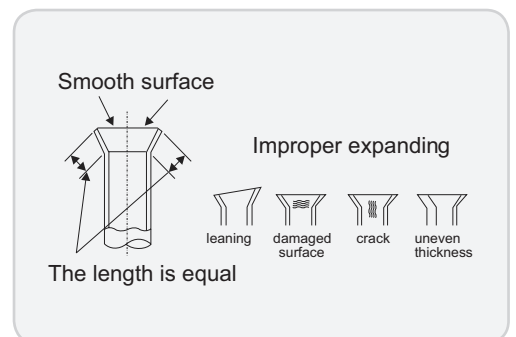

## Appendix 4: List of Resistance for Temperature Sensor

### Resistance Table of Ambient Temperature Sensor for Indoor and Outdoor Units (25K)

Temp(°C)	Resistance(kΩ)
-19	138.10
-18	128.60
-16	115.00
-14	102.90
-12	92.22
-10	82.75
-8	74.35
-6	66.88
-4	60.23
-2	54.31

Temp(°C)	Resistance(kΩ)
0	49.02
2	44.31
4	40.09
6	36.32
8	32.94
10	29.90
12	27.18
14	24.73
16	22.53
18	20.54

Temp(°C)	Resistance(kΩ)
20	18.75
22	17.14
24	15.68
26	14.36
28	13.16
30	12.07
32	11.09
34	10.20
36	9.38
38	8.64

Temp(°C)	Resistance(kΩ)
40	7.97
42	7.35
44	6.79
46	6.28
48	5.81
50	5.38
52	4.99
54	4.63
56	4.29
58	3.99

### Resistance Table of Tube Temperature Sensors for Indoor and Outdoor (35K)

Temp(°C)	Resistance(kΩ)
-19	181.40
-15	145.00
-10	110.30
-5	84.61
0	65.37
5	50.87
10	39.87
15	31.47

Temp(°C)	Resistance(kΩ)
20	25.01
25	20.00
30	16.10
35	13.04
40	10.62
45	8.71
50	7.17
55	5.94

Temp(°C)	Resistance(kΩ)
60	4.95
65	4.14
70	3.48
75	2.94
80	2.50
85	2.13
90	1.82
95	1.56

Temp(°C)	Resistance(kΩ)
100	1.35
105	1.16
110	1.01
115	0.88
120	0.77
125	0.67
130	0.59
135	0.52

### Resistance Table of Discharge Temperature Sensor for Outdoor (50K)

Temp(°C)	Resistance(kΩ)
-30	911.400
-25	660.8
-20	486.5
-15	362.9
-10	274
-5	209
0	161
5	125.1

Temp(°C)	Resistance(kΩ)
10	98
15	77.35
20	61.48
25	49.19
30	39.61
35	32.09
40	26.15
45	21.43

Temp(°C)	Resistance(kΩ)
50	17.65
55	14.62
60	12.17
65	10.18
70	8.555
75	7.224
80	6.129
85	5.222

Temp(°C)	Resistance(kΩ)
90	4.469
95	3.841
100	3.315
105	2.872
110	2.498
115	2.182
120	1.912
125	1.682



**DELTRON**<sup>®</sup>

A **BEIJER REF** Company

**Split**, Vukovarska 148  
Tel: +385 (0)21 453 400  
Fax: +385 (0)21 473 943  
deltron@deltron.hr

**Zagreb**, Zagrebačka avenija 104  
Tel: +385 (0)1 60 64 777  
Fax: +385 (0)1 60 64 778  
deltron.zagreb@deltron.hr

**Sarajevo**, Pijačna 14k, 71000  
Tel: +387 (0) 33 840 200  
Fax: +387 (0) 33 840 203  
deltron.sarajevo@deltron.ba

DISTRIBUTOR



[www.deltron.hr](http://www.deltron.hr)